



Installation and User Manual



SOLARIS

Dear Customer

Thank you for purchasing SOLARIS solid fuel boiler. This instruction manual is intended to help you install and operate the product safely, properly and economically. Please read this manual carefully before installation and operation of your product, and keep it during the whole operation life. Do not touch or interfere any part of the product other than those allowed. The installation, maintenance and service of this boiler requires skilled technicians. For the installation of the boiler and proper room selection, installation of water circuit, chimney design, this manual and mandatory regulations must be considered.

Carry out maintenance and cleaning work recommended on your heating system at regular intervals. Details can be found later in the instruction manual. By doing this, you will not only be ensuring the operational reliability of your heating system but also its efficient and low-emission operation

Your boiler's output will vary according to volume of fuel load in the upper chamber between 100% of the boiler's rated power and a reduced value, or your heating system may have a lower demand than the boiler can deliver. For this reason we strictly recommend that an accumulation tank is installed. The accumulation tank ensures operational reliability of the appliance and improves heating response and energy saving, protecting the boiler from condensation due to lower inlet/outlet temperatures and woodgas formation, ensuring efficient and low-emission operation of your boiler. The accumulation tanks must be accomplished with a three-way valve system between inlet and outlet lines of boiler to maintain higher inlet temperatures to boiler at all times.

DECLARATION OF CONFORMITY

According to Regulation (EU) No 2015/1189

No. 0106_A

Type of the equipment	: Hot water boilers for solid fuel (wood) with manual fuel supply EN 303/5:2012
Trademark	: Thermasis
Type designations	: SOLARIS 18 SOLARIS 25 SOLARIS 32 SOLARIS 40
Manufacturer	: BOYSIS MAKINE TAAHHUT SANAYI ve TICARET A.Ş. Şerifali Mahallesi Hüsrev Sokak No.2 Erişkenler Plaza Kat 3, 34775, Istanbul/TURKIYE
Certificate of Conformity released by With certificate/report number	: "SZU" (NB 1045), Hudcova 424/56B, 621 00, Brno 39/11175/T1 and /2

The following harmonised standards or regulations which comply with good engineering practice in safety matters in force within the EU have been applied:

EN 303/5 of 2012: Solid fuel boilers, manually and automatically fired, nominal heat output up to 500 kW - Terminology, requirements, testing and marking

DIRECTIVE 2015/1189/EC of 28 April 2015; implementing Directive 2009/125/EC of the European Parliament and of the Council as regards eco-design requirements for solid fuel boilers

DIRECTIVE 2011/65/EU of 8 June 2011 on the restriction of the use of certain hazardous substances in electrical and electronic equipment

DIRECTIVE 2014/35/EU OF OF 26 February 2014 on the harmonisation of the laws of the Member States relating to the making available on the market of electrical equipment designed for use within certain voltage limits

DIRECTIVE 2014/30/EU of 26 February 2014 on the harmonisation of the laws of the Member States relating to electromagnetic compatibility

As manufacture and/or authorised representative within EU, we declare under our sole responsibility that the equipments follow the essential requirements foreseen by the above mentioned regulations

Signed for and on behalf of the manufacturer by:

Murat Gedik [Sales Consultant]
Bursa, September 21st, 2022



1 INTRODUCTION / WARRANTY CONDITIONS

Solaris is a welded steel boiler designed for efficient burning of woodlogs to be used in hot water heating installations. Therefore, it can not be used for direct sanitary water supply. Main features and advantages of Pyrocal boiler:

- **Fully electronic boiler control functions:** Operation is controlled by an electronic board with useful functions. Draught fan is driven in accordance with desired boiler outlet temperature. Modulation of fan speed ensures correct adjustment of boiler outlet temperature with high comfort. Heating circuit pumps is operated always at higher boiler temperatures to minimize condensation rate and protect boiler heating surfaces. Control panel has an additional contact for room thermostat connection. Control panel shutdowns the fan and the pump when there is no fuel in the wood storage, and warns the user. If boiler temperature exceeds 110 °C, control panel switches the fan off, heating circuit pump keeps on operation, system and boiler is protected, and a buzzer alarm warns the user.

A domestic hot water cylinder can be integrated to the system, and dhw pump can be driven by original control panel of the boiler. When the loading door is opened, suction fan automatically switches to maximum speed for better by-pass function.

- **Double layer loading chamber:** Dry internal surface by protecting shields in gasification chamber improves gasification process, and extends boiler lifetime.
- **Advantages of fan at smoke outlet:** Suction fan eliminates firing problems and keeps combustion chamber always in negative pressure. It helps ensure easy control on primary and secondary air, increasing water efficiency of the boiler. Automatic restarting of firewood is performed in presence of a minimum quantity of embers in wood storage.
- **Primary and secondary air regulation:** Manual adjustment of primary and secondary air volumes helps improve combustion and flue gas emissions. Primary and secondary air dampers are set at factory for each model for optimized combustion.
- **High temperature resistant cast refractory burner:** Special cast high alumina refractory burner with reinforcement additives against thermal stresses and humidity can operate up to 1600 C, and ensures good mixture of wood gas with secondary air, improving combustion and emissions
- **High efficiency with increased heating surface:** Additional water cooled surfaces after combustion, designed as horizontal three pass principle increase heat transfer rate, reduce flue outlet temperature, with average water efficiency 90%.
- **Integrated cooling loop for safety against overheating:** A cooling loop made of copper tube is integrated inside the boiler. Inlet and outlet connections of this cooling loop is outboard at the top of the boiler. A safety valve to activate the heating system at high water temperatures should be attached for proper work of safety system. Whether the hydraulic circuit is open vented or pressurised, the safety valve should be utilized within the system for meeting the regulations of related European standard for this product, as well as the safety of whole heating installation and the boiler itself.

Solaris is delivered in one single package on a wooden pallet with control panel, fan, this manual, cleaning brush, and fuel shaker arm included, and external cabinet fit before leaving factory.

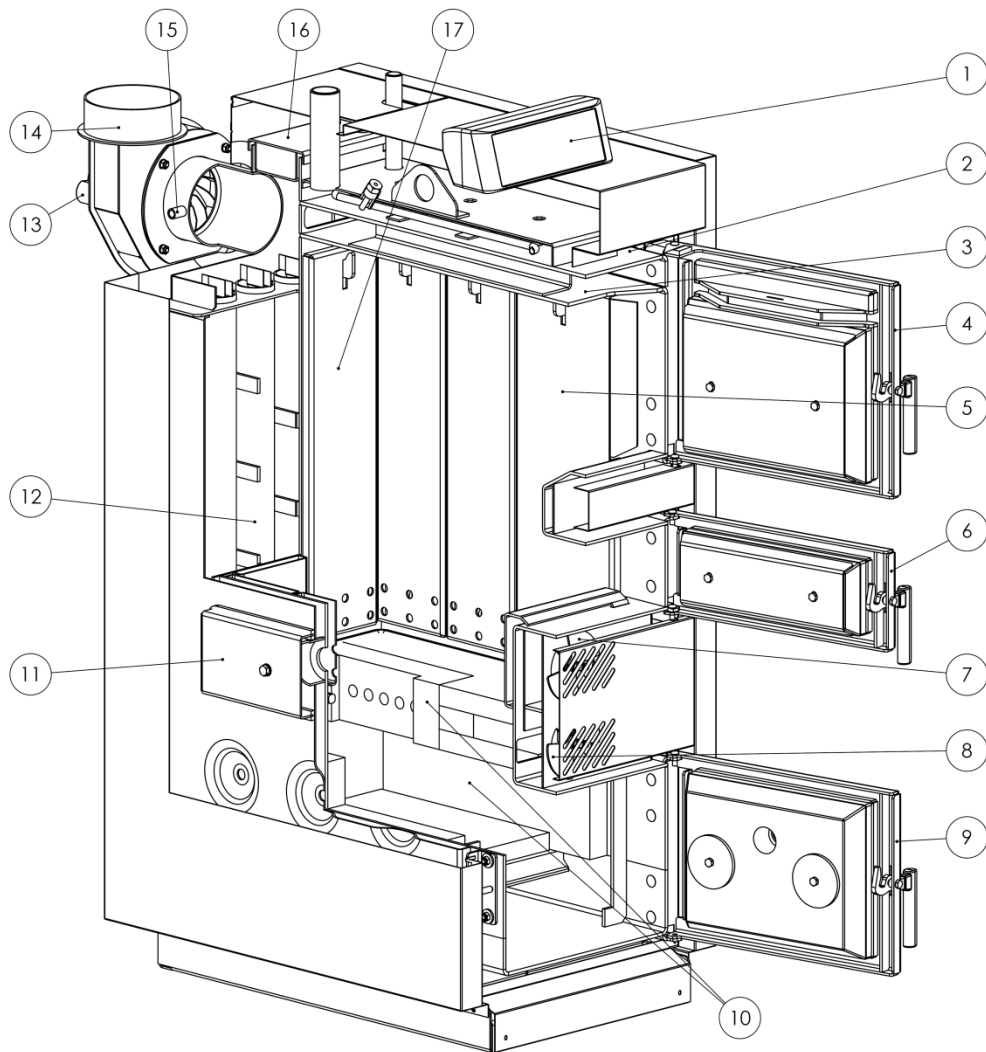

- 1 Control panel
- 2 Door switch
- 3 Smoke by-pass
- 4 Front loading door
- 5 Fuel (gasification) chamber
- 6 Ignition and cleaning door
- 7 Primary air flap
- 8 Secondary air flap
- 9 Front ash door
- 10 Combustion chamber refractories and burner
- 11 Primary air manifold
- 12 Heat exchanger pipes
- 13 Suction fan
- 14 Flue outlet
- 15 Flue gas temperature sensor
- 16 Cleaning cover -1
- 17 Wood storage protector plates

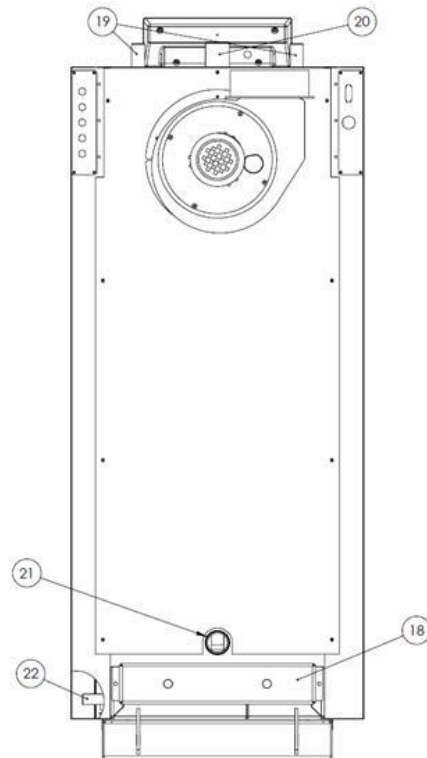

- 18 Cleaning cover - 2
- 19 Cooling loop connection for safety valve (3/4")
- 20 Delivery (1 1/2")
- 21 Return (1 1/2")
- 22 Filling / draining (1/2")

WARRANTY CONDITIONS

THE MANUFACTURER guarantees the product, with the exception of elements subject to normal wear (listed below), for a period of 2 (two) years;

- Starting from date of start-up, which is proven by a commissioning document that contains the name of the seller and the date when the sale / first start-up took place
- If there is no service/commissioning report, standard guarantee period starts with the date when the sale took place.

The term 'warranty' refers to the (free-of-charge) replacement or repairs of parts acknowledged to be faulty due to manufacturing defects.

Furthermore, in order for the guarantee to be valid, the product must be installed and calibrated by qualified personnel. Installations that do not meet the current standards, improper use and lack of maintenance as expected by the manufacturer, void the product warranty. The warranty is valid on the condition that the instructions and warnings contained in this manual are observed, and therefore the product is used correctly.

The replacement of the entire system or the repair of one of its components does not extend the warranty period, and the original expiry date remains unchanged.

EXCLUSIONS FROM WARRANTY

Parts subject to normal wear such as gaskets, ceramic glass, cast iron grilles, vermiculite boards, fire bricks, fire stone burners, handles and electric cables, knobs, all parts which can be removed from the firebox, are excluded from the warranty

Any part that may be faulty as a result of negligence or careless use, incorrect maintenance or installation that does not comply with the manufacturer's instructions (see the relative chapters in user manuals of each product).

The warranty will be rendered null and void in the event of damage caused by tampering, atmospheric agents, natural disasters, vandalism, electrical discharges, fire, faults/defects in the electric and/or hydraulic system, and maintenance not being performed at all or as indicated by the manufacturer instructions

Non-regular electrical supplies, and electrical power cuts off too often, can cause severe damage on control system, sensors and actuators of the products carrying those components. We recommend installing 230 V 50 Hz AC voltage regulator for those products. Also installing a UPS for pumps can protect system from electrical cut-offs causing over heating of water.

The warranty does not cover malfunctions and/or damage to the appliance that arise due to the following causes:

- Damage caused during internal transportation and/or handling
- All parts that develop faults due to negligence or improper use, incorrect maintenance, installation that does not comply with the manufacturer's instructions (always refer to the installation manual provided with the product)
- Improper overheating of the equipment, use of fuels not conforming to the types and quantities indicated in the instructions provided
- Further damage caused by incorrect user interventions in an attempt to fix the initial fault
- Worsening of the damage caused by the user continuing to operate the appliance even after the fault has been noticed.
- In case of a boiler/hydro stove, any corrosion, incrustations or breakages caused by water flow, condensation, lack of water in the system, mud or limescale deposits
- Inefficiency of chimneys, flues or parts of the system affecting the appliance.

- Failure to have the annual product maintenance performed by an authorised technician or qualified personnel will result in the loss of the warranty.
- Save for the legal or regulatory limits, the warranty does not cover the containment of atmospheric and acoustic pollution.

THE MANUFACTURER declines all liability for any damage which may be caused, directly or indirectly, to persons, animals or objects as a consequence of non compliance with any provision specified in the manual, especially warnings regarding installation, use and maintenance of the appliance.

SPARE PARTS

Only use original spare parts. The retailer or service centre can provide all necessary information regarding spare parts. We do not recommend waiting for the parts to get worn out before having them replaced. It is important to perform regular maintenance.

The Manufacturer declines all liability if the product and any other accessory is used improperly or modified without authorisation. All parts must be replaced with original spare parts. Warranty cover is valid if the product is installed and tested by a qualified installer, according to the detailed instructions provided in the instruction manual supplied with the product. The term 'warranty' refers to the (free-of-charge) replacement or repairs of parts acknowledged to be faulty due to manufacturing defects.

2 SAFETY WARNINGS

3.1 Basic safety instructions

- Never get yourself into danger; give own safety the utmost priority.
- Keep children away from the boiler room and fuel storage room.
- Observe all instructions related to operation, maintenance, servicing and cleaning.
- The heating system may only be installed and started up for the first time by an authorised installer. Professional installation and start up are essential for safe and economical operation.
- Never make any changes to the heating system or flue gas system.
- Never close or remove safety valves.

3.2 Warning signs

DANGER – Risk of poisoning

- Make sure that the boiler is supplied with sufficient combustion air.
- The openings in the combustion air inlet must never be partially or completely closed.
- Ventilation systems, central vacuum cleaning systems, extractor fans, air conditioning systems, flue gas blowers, dryers or similar equipment must never be allowed to draw air from the boiler room and cause a drop in pressure.
- The boiler must be connected tight to the chimney using a flue gas tube.
- Clean the chimney and the flue gas tube at regular intervals.
- The boiler room must be sufficiently supplied with air and ventilated.

DANGER – Risk of electric shock

- Switch off the system before performing work on the boiler.
- **THIS APPLIANCE MUST BE EARTHED !**

- Electrical installation of this boiler must be completed in accordance with mandatory regulations, and codes of practice regarding the instructions given in this manual by authorized installator.

DANGER – Risk of explosion / fire

- Never burn petrol, diesel, or other explosive materials in the boiler or storage room
- Never use liquids or chemicals to ignite the wood
- Do not store any flammable materials in the boiler room.
- Do not hang out any washing in the boiler room.
- Always keep all boiler doors closed
- Store the woodlogs in another room, or leave a minimum distance of 80 cm between the boiler and the woodlog pile.

DANGER – Risk of burns

Risk of burns

- Do not touch the flue spigot or the flue gas tube.
- Do not touch the front door surfaces (except for door opening handles), rear cleaning covers, and smokehood section named as boiler working surfaces when there is fire, which are marked with red rectangle on the right hand side
- Do not reach or clean the boiler' s inside until it has been allowed to cool down.

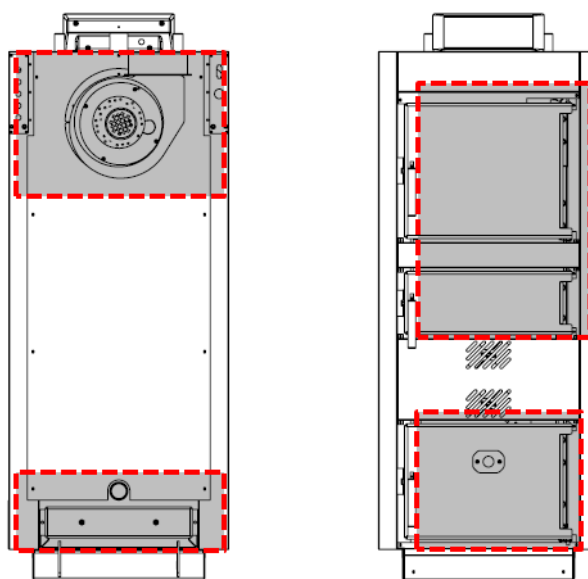

CAUTION – Sharp edges

Risk of cut injuries due to sharp edges.

- Use gloves for performing all work on the boiler.

NOTICE

Damage to property

- Heat the pellet heating system using pellets that comply with the specifications below

Damage to property

- Do not use the heating system if it, or any of its components, come into contact with water.
- If water damage occurs, have the heating system checked by your authorised service staff or approved technicians, and have any damaged parts replaced in case needed.

3.3 What to do in an emergency

What to do in the event of a fire

- Switch off the heating system.
- Call the fire brigade
- Use approved fire extinguishers.

What to do if you smell smoke

- Switch off the heating system.
- Close the doors leading to living areas.
- Ventilate the boiler room.

3 WARNING ON GASIFICATION AND PROPER FUELS

Wood and gasification: It is very important that wood gasification boilers work in specific conditions. Boiler's average temperature should be around 70 - 80 °C. At lower temperatures gasification process does not take place in a correct way. This will result in more fuel consumption and lower heat outputs than declared for each model.

Wood drying in the wood storage (loading chamber or gasification chamber) is an essential stage in gasification process. Wood will not have adequate temperature for wood gas formation at lower boiler temperatures and all of the process is inadequate. Main warming source in loading chamber is gas flame arising during gasification. So, if the main conditions for correct gasification is not achieved, then both quality and quantity of wood gas will not be sufficient.

Proper fuels: In gasification boiler, you can fire only wood, particularly hardwood. Wood must be dry. It is important that thermal value of the wood is primarily dependent upon the moisture content. The moisture of the wood must be between 12 - 20%. Moisture can be measured easily by a simple device purchased commercially. If moisture is above 20%, logs must be dried before use.

Firewood must be split and its size must be adapted accordingly to fit in loading chamber. Unsplit logs and square boards are not suitable for burning. Length of woodlogs should be equal to free length of loading chamber at its best. Bigger logs must be cut into smaller sizes to fit best in the loading chamber. Best way is to split logs before they are prepared for drying.

High moisture content and firing unsplit wood have negative impact on combustion efficiency of boiler and result in higher fuel consumption. The calorific value of firewood should preferably be between 15 to 17 MJ/kg. Suggested fuels:

Wood	Heating capacity for 1 kg		
	kcal	MJ	kWh
Spruce	3900	16,2	4,5
Pine	3800	15,8	4,4
Birch	3750	15,5	4,3
Oak	3600	15,1	4,2
Beech	3450	14,4	4

To operate boiler in full gasification mode with optimized efficiency

- Keep inlet and outlet temperatures of boiler at maximum (average should be 70-80°C)
- Use dried woodlogs with parameters suggested above
- Load the fuel chamber fully and operate the boiler at declared maximum output. The boiler must not be permanently operated with output levels lower than 50% of its nominal output. Ecological operation of this boiler at its nominal output.
- Use an accumulation tank with a proper size for heat output
- Use necessary means to increase inlet water temperature to boiler in accordance with the instructions given further in this manual.
- Clean boiler surfaces regularly against excessive soot and tarr accumulation which will have negative effect on boiler performance
- All above precautions on boiler system will also minimize the condensation and tarr formation on boiler surfaces particularly inside the loading chamber, thus protecting boiler material against corrosion to reach longer operation lifetime.

4 TECHNICAL DATA

Model		SOLARIS			
Types		SLS 18	SLS 25	SLS 32	SLS 40
Description of boiler		Welded steel boiler for dry wood logs, in pyrolytic combustion principle, with negative pressure in combustion chamber driven by exhaust fan at flue			
Fuels		Dry wood logs			
Output	kW	18	25	32	40
Net weight	kg	405	465	480	580
Water content	lt	72	87	91	124
Total heating surface	m ²	2,60	3,10	3,25	4,30
Fuel container volume	dm ³	90,0	120,0	130,0	140,0
Maximum wood log length	cm	50,0			
Fuel loading clearance (H x W)	mm	280x320	280x370		350x370
Flue gas temperature	C	< 150			
Required draft at chimney (min-max)	Pa	8 - 23			
	mbar	0,08 - 0,23			
Temperature control range	C	65 - 90			
Maximum operating temperature	C	100			
Minimum return temperature	C	65 (recommended)			
Safety system activated at	C	95			
Maximum operating pressure	bar	3			
Water flow/return connections (F/R)	R	1 1/2"			
Cooling loop connections (HE)	R	3/4"			
Filling / draining connection (FD)	R	1/2"			
External dimensions					
H H1 H2 W L1 L D	mm	1325	1425	1475	1545
	mm	240			
	mm	125			
	mm	545	595	595	595
	mm	840	855	855	855
	mm	1160	1175	1175	1175
	mm	160			
	mm				
Electrical supply		230 V / 50 Hz			
Power consumption	W	50			

Fuel type	Wood logs	
Combustion period at max load	h	6 to 8
Requested fuel parameters	Allowable water content 12 - 20%	
	Average calorific value 15.000 - 17.000 kJ/kg	
Allowable wood log size	Diameter between 7 cm - 15 cm	

SLS 18

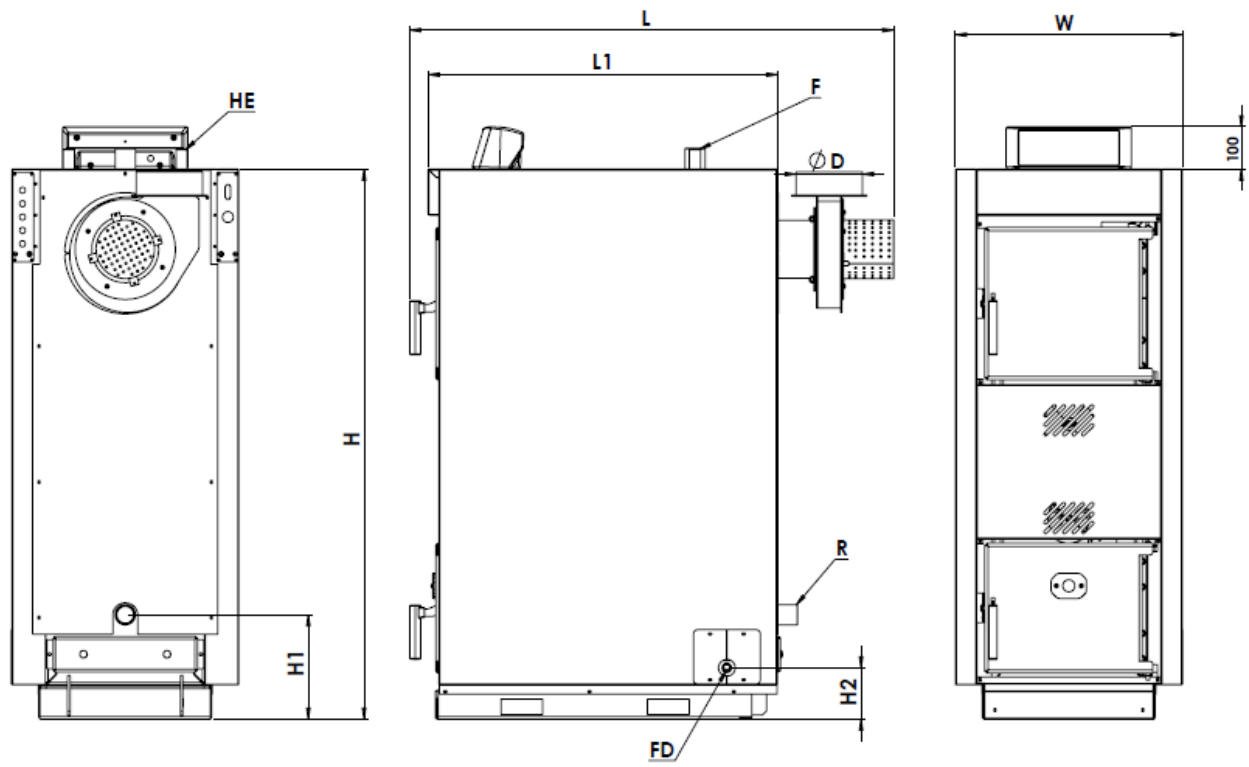

SLS 25 / 32 / 40

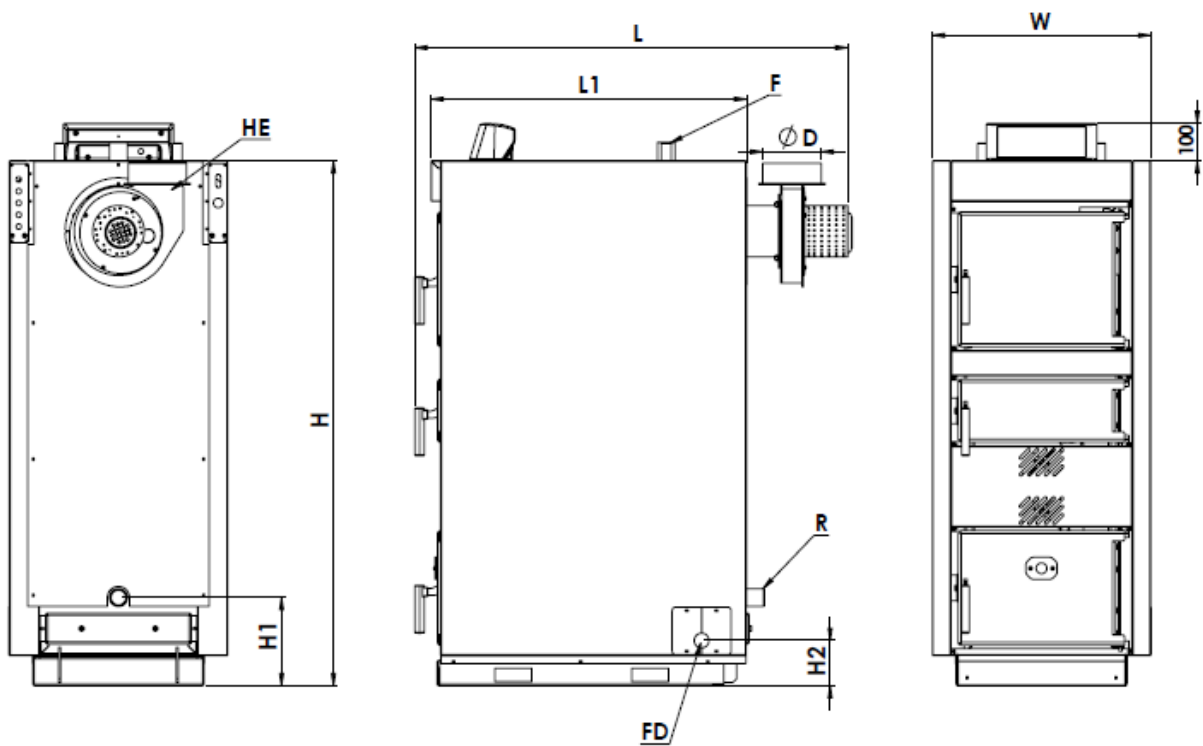

5 INSTALLATION

5.1 Handling the product

Solaris is a heavy product, and care should be taken when carrying the boiler to the room where it is going to be installed. The total weight of each boiler is indicated in technical data section. Carrying equipment of the product must be of enough capacity to support that weight. To avoid damage during transport, boiler should be moved with forklift or transpalet. Use the transport feet on the wooden pallets.

NOTICE – Damage to property	
•	Do not use hard and sharp objects while removing the package around the boiler to prevent damage of the painted jackets.

5.2 Room selection

Boiler must be installed in an individual boiler room particularly organized for heating. The boiler room should be of enough volume for installation, firing, and maintenance of the boiler. There should be enough fresh air circulation for combustion, the chimney design must ensure an dequate draught for related boiler type, and must comply with construction criteria given further in this manual and in mandatory regulations. Your boiler must never be installed in open spaces or balconies, in spaces occupied by people like kitchen, living room, bathroom, bedroom, in spaces where there are explosive and combustibile materials.

The boiler room should have air ventillation holes through outside to let fresh air in. One air ventillation hole must be built maximum 40 cm below the level of room ceiling, the other must be built maximum 50 cm above the floor level. These ventillation holes should always be kept open. The upper hole should be at least 40x40 cm in size, the lower hole at least 30x30 cm. All hydraulic and electrical circuits must be arranged by authorized staff in accordance with mandatory regulations specified by legal organizations. Solid fuels should be stored by keeping minimum 800 mm distance from the boiler. We recommend you to keep the solid fuel in another room. Boiler should be installed on a concrete plinth made of a fireproof material. For minimum sizes of the plinth following table should be referred

Model		SLS-18	SLS-25	SLS-32	SLS-40	SLS-50
Plinth height	mm	50				
Plinth width	mm	550	600			700
Plinth length	mm	850	900			1100

5.3 Clearances around boiler

At least the following clearances (in mm) should be achieved around the boiler:

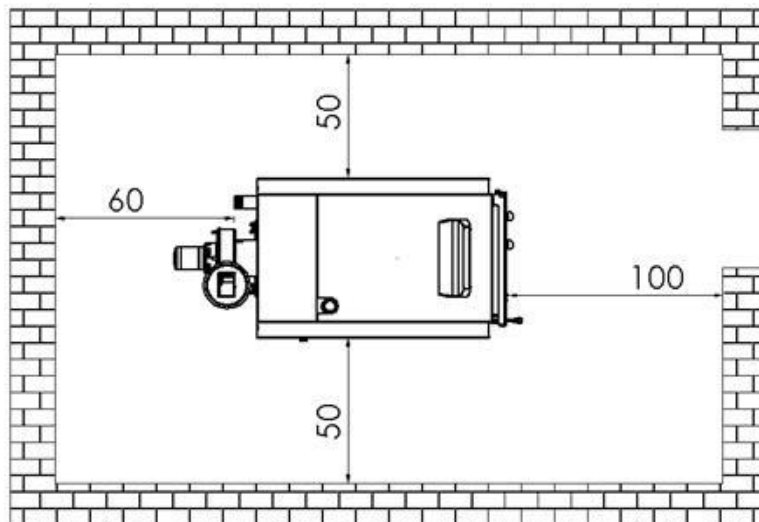

5.4 Circulation pump

We recommend building a forced water circulation system accompanied with a sufficient pump. Refer to the system diagrams given further in this manual to find the right position of the pump within the hydraulic circuit. Your boiler automatically switches the pump on and off according to the program stored in its PCB. That is why circulation pump must be driven by the control panel. Wiring to the pump is supplied at the back of the boiler. The pump will automatically start when boiler outlet water temperature exceeds set value for pump and will automatically switch off when temperature falls below this value. This feature will help prevent boiler from condensation in flue.

5.5 Rules for hydraulic circuit

Boiler at its best should be installed in a pressurized heating circuit accompanied with an accumulation tank with addition of a closed expansion tank in respect with the following scheme.

If you install your boiler together with an accumulation tank with a help regulation device with integrated by-pass flow control, you will have higher field efficiency from your heating system installation together with higher comfort and better protection of system components. For this reason we recommend following installation scheme with regulation control units that can be found in the market (such as Laddomat-21, Regulus Thermovar LK810). For proper sizing regulation unit and accumulation tank according to your boiler and total heated area size, please refer to the instructions supplied by the manufacturers regulation unit.

We recommend a buffer storage tank capacity of 50 to 70 litres per kW boiler output if the system is based purely on wood and not combined with an oil or gas-fired heating. In any case, this volume should not be lower than 25 litres per kW boiler output.

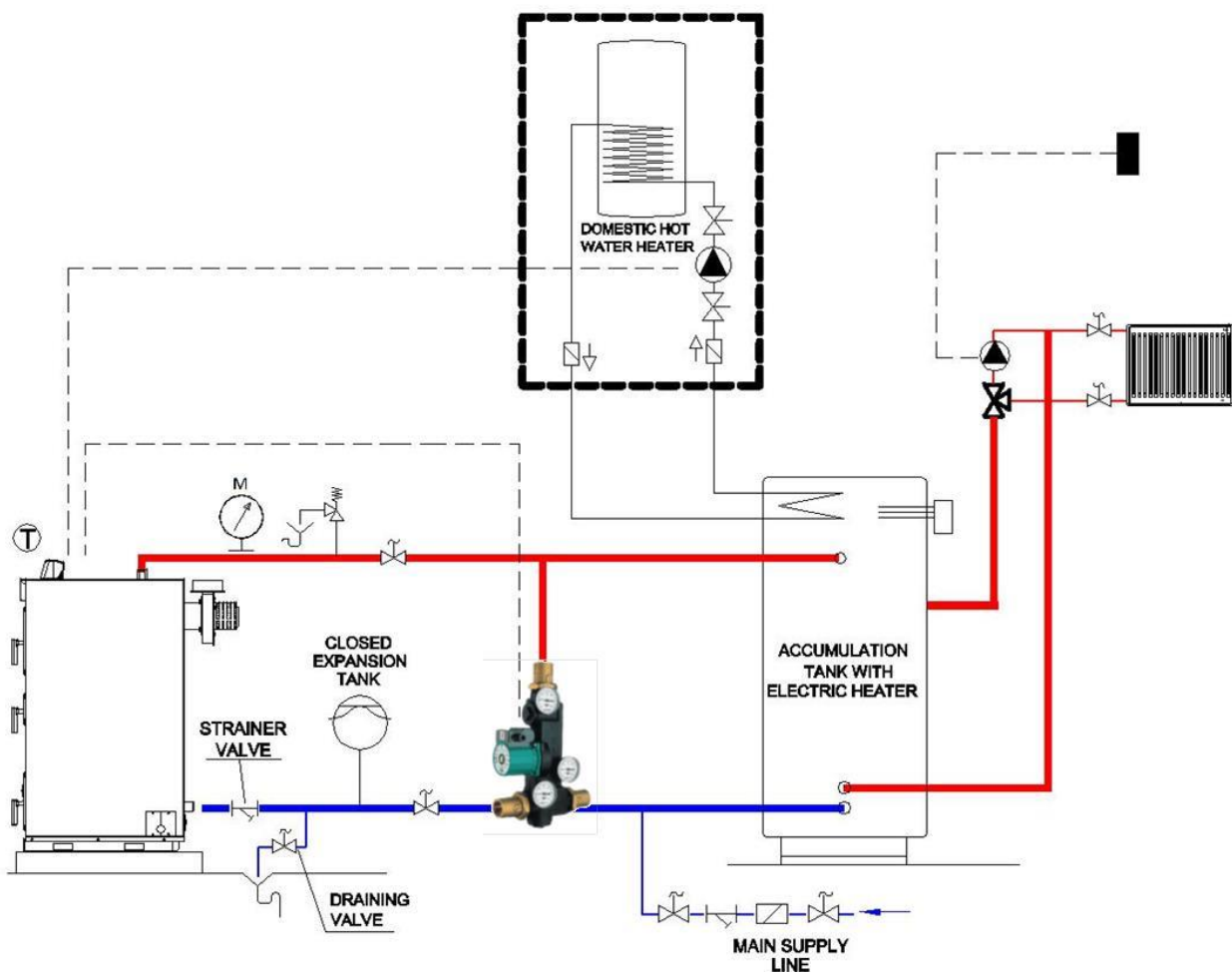

For above scheme:

- Circulation pump outlet must be wired to the pump on the regulation unit, and pump activation temperature should be set to minimum value on boiler's control panel
- Boiler outlet temperature should be adjusted always to 80 to 90 °C to feed accumulation tank.

- The system pump between accumulation tank and radiators should be driven externally preferably through a room thermostat that can be purchased by the end-user. If needed or better comfort for system water temperature a manually set three-way valve can be added on radiator system between inlet and outlet lines.
- Domestic hot water pump is controlled by the boiler, and DHW thermostat is supplied as standard.

If you can not install regulation unit, following scheme could be achieved with accumulation tank:

- A thermostatic three way valve sized to match boiler's delivery rate which is set 65°C must be added between inlet and outlet lines of the boiler.
- Circulation pump outlet must be wired to the pump on by-pass line, and pump activation temperature should be set to minimum value on boiler's control panel
- Boiler outlet temperature should be adjusted always to 80 to 90 °C to feed accumulation tank.

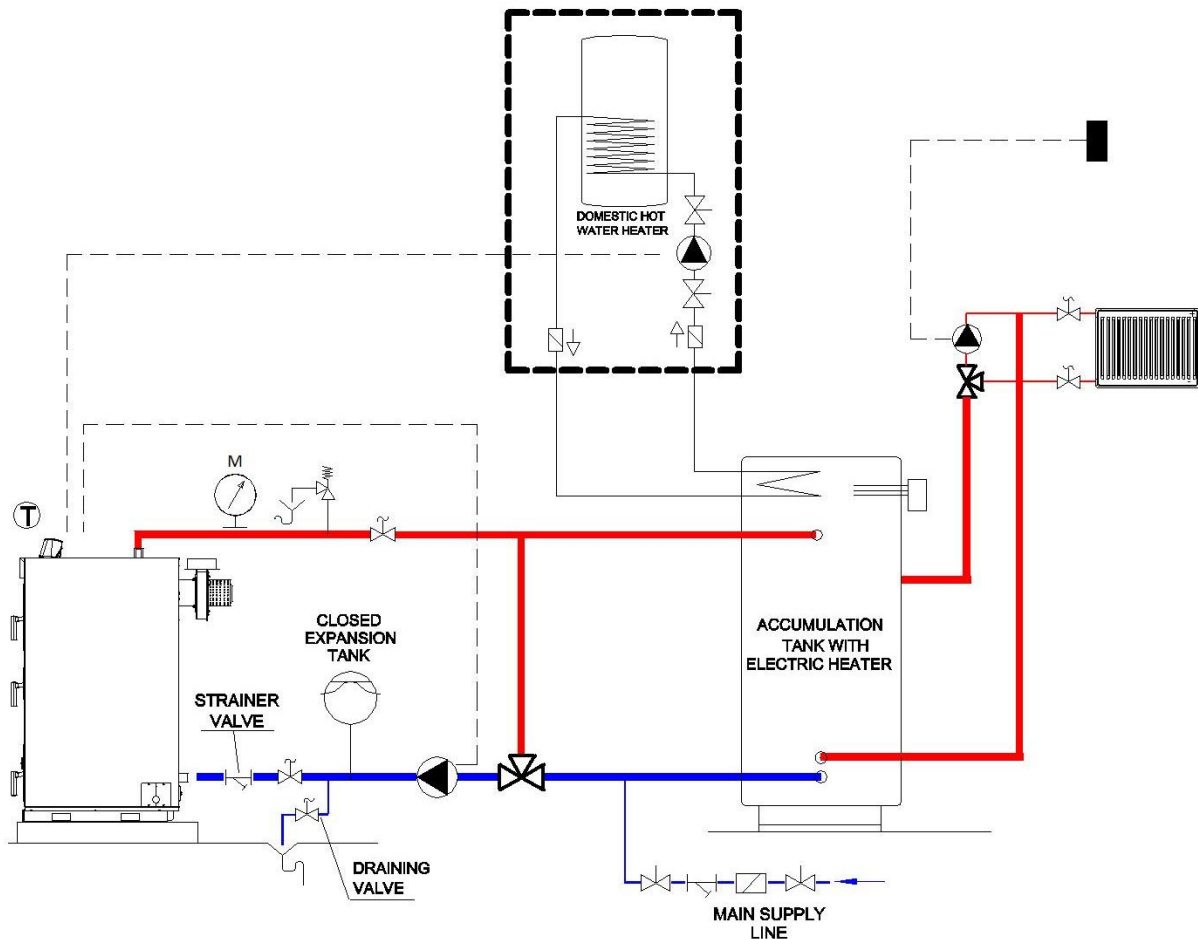

NOTICE – Safety of heating circuit

- Install a ½" safety valve with a maximum relief pressure of 3 bars.
- Install a manometer to follow and check water pressure in the system. When water is cold, system pressure should be set at 1 - 1,5 bars.

WARNING – Risk of corrosion

- Your boiler is of quite a strong design against corrosion. However, all metal surfaces in whole heating circuit should be protected against corrosion like piping and radiators. The oxygen in heating water will cause rust and then material loss on iron-based metal surfaces by means of oxidation.
- During the first water make-up, oxygen must be fully discharged from the system. Generally, oxidation will not be a problem, if all measures are taken into account during first water make-up. Oxidation will take place because of fresh water addition to the system during operation of the boiler. Leak points in a system will cause oxygen to be absorbed inside the heating water. For this reason, minimum water pressure in a pressurized heating circuit must be above atmospheric pressure. Besides, pressure level should always be checked periodically.

CAUTION – For new installations

- System should be sized and designed accordingly, in order to minimize fresh water addition. Make sure that no part of the system is made of material that is permeable to gases. The original system filling and any topping-up water must be filtered (using synthetic or metal mesh filters with a filtration rating of no less than 50 microns) to prevent sludge from forming and triggering deposit induced corrosion. Minimum water pressure in heating circuit must always be kept above atmospheric pressure

CAUTION – For a new boiler installed on an old heating circuit

- In old systems used for a long time, a protective coating (black magnetite) has been built on all metal surfaces contact with water. This coating protects the system against further corrosion. When a new boiler is installed in such an old system, new parts with clean metal surfaces, particularly boiler surfaces will inevitably become sacrificial anode for the entire heating system, in other words, they come in the first place where corrosion starts. That is why, following precautions should be added to those given above, for a new boiler in an old system:
- If the old system has an open expansion tank, this may be converted to a pressurized system with all necessary safety measures.
- The old system must be fully washed up from all substitutes and particles contained on the surfaces.
- An air separator with manual vent should be installed at the highest level of the circuit.

5.6 Safety against over-heating

Boiler has an integrated cooling loop made of copper against overheating. During the installation of the boiler 3/4" connections to and from cooling loop at the top of the boiler must be used for safety circuit of the boiler and whole heating system as well. A safety valve must be purchased separately and installed according to the schemes below:

If the boiler water temperature exceeds 95 °C, thermostat of the safety valve lets cold sanitary water flows through the serpentine of the safety cooling loop. Serpentine with cold water circulating inside cools down the boiler water temperature. When the boiler temperature decreases below the safe degree, safety valve shuts the cold sanitary water circulation, and the boiler goes back to normal operation. The valves on the sanitary connections of safety heat exchanger must always be kept open. Cold water must never be delivered directly to boiler inlet in order to solve overheating problems as this will result in serious damage on boiler body. That application will end warranty of the boiler.

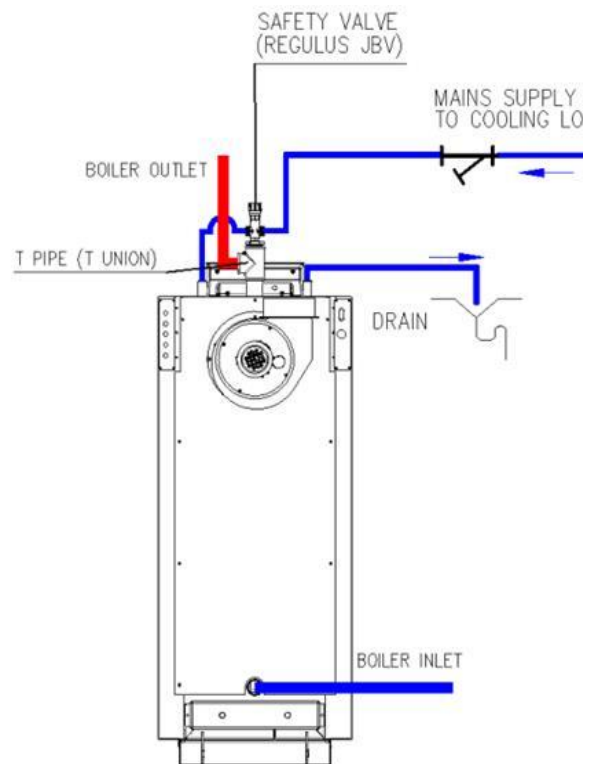

NOTICE

- Cold water pressure for safety heat exchanger must be reduced to 2 bars before safety valve inlet.

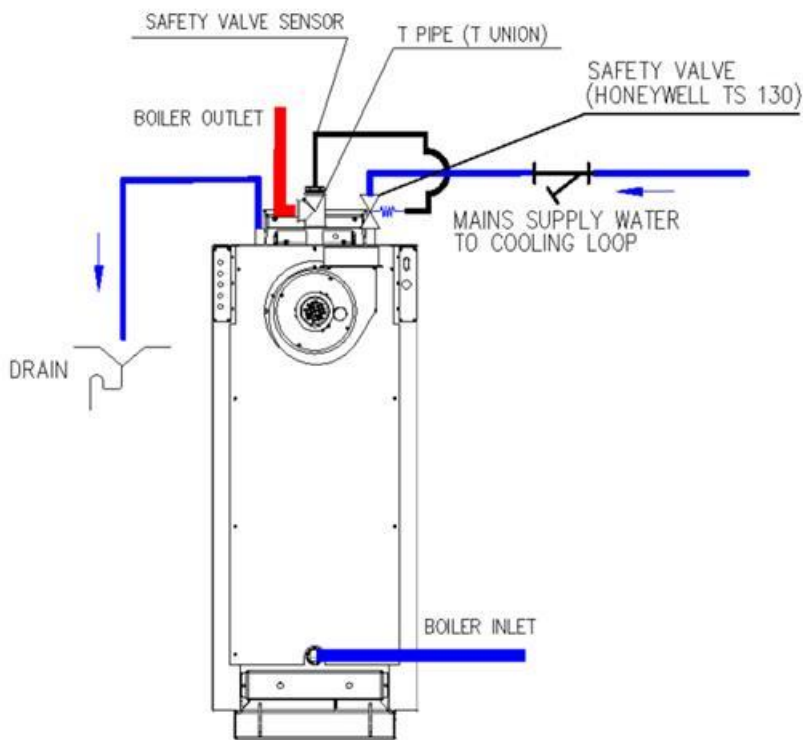

5.7 Chimney connection

Boiler must be connected to an individual chimney that will provide at least the minimum draught requested. The flue channel between the boiler and the chimney should be insulated using a glass wool material. The flue channel to chimney and chimney must be made of steel or an equivalent material that can be used at temperatures around 400°C. All connections on the flue system must be sealed in order to perform a good combustion and efficiency. The flue channel must be connected to the chimney using the shortest way and in accordance with the dimensions given in the following scheme. Horizontal connections and equipments that will increase the pressure loss such as elbows should be avoided.

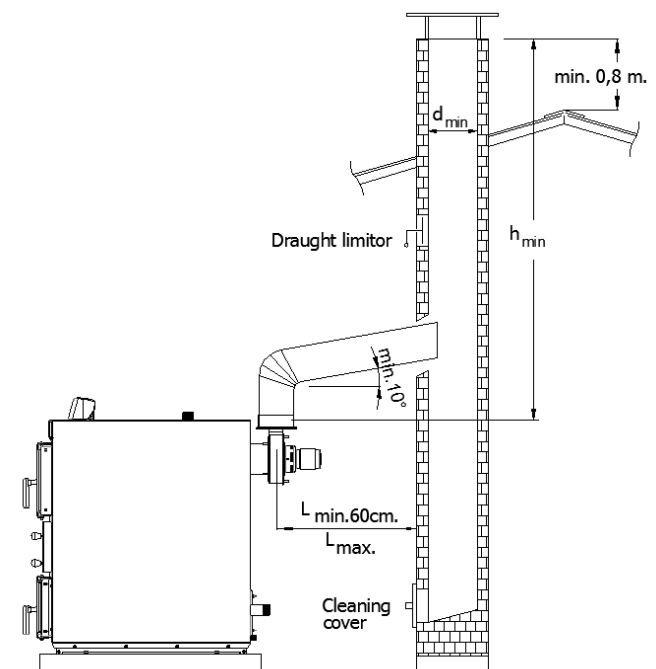

A vertical single steel piping should not be used as a chimney. Chimney must be made of one internal and one external surface. External surface may be made of steel or brick. For internal surface stainless steel chimney elements should be preferred against corrosion. The space between internal and external surfaces of the chimney should be insulated to prevent condensation in flue gasses.

At the lowest level of chimney, there should be a cleaning cover which is made of steel, and sealed for any leakage. The length of flue channel between the boiler and the chimney should not exceed ¼ height of chimney. The size of flue channel and chimney should not be less than the size of the boiler flue gas outlet connection. For the total height and the minimum internal diameter of the chimney, following diagram should be referred in respect with boiler output power, if otherwise stated in mandatory regulations.

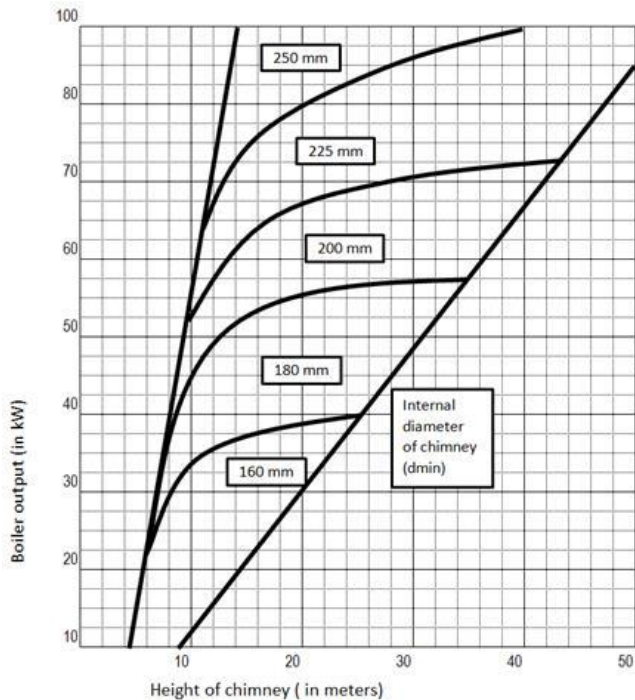

5.8 Electrical installation and wiring complete

The boiler is fed with 230 V. A regulator must be used in installations where the power supply is below 205 V or above 230 V. Control panel should be connected to a wall plug with an efficient ground system, which is placed not far more than 50 cm. to boiler with a circuit breaker which has at least 3 mm gap between contacts. For this reason, if a new electrical installation is required, 3x1,5 TTR cables must be used.

WARNING

All electrical installations must be carried out by authorized persons in accordance with mandatory regulations and codes of practice. Only qualified personnel may open the control panel on the boiler. Any interference with the wiring in the control panel will invalidate the warranty.

Follow the instructions to finish the assembly of boiler accessories supplied together with the boiler

1. Remove the top jacket of the boiler from their original place. Before fixing the control panel to top jacket, first draw all wires and sensor cable of the panel through the holes on top panel. Fix the control panel to jacket by using four pieces M5 setcrews supplied with the boiler.



2. Fix safety thermostat to the top panel, inserting its reset button side through the corresponding hole on top cover, positioned behind the control panel. Secure the thermostat by its original washer and plastic cap as shown on following pictures.

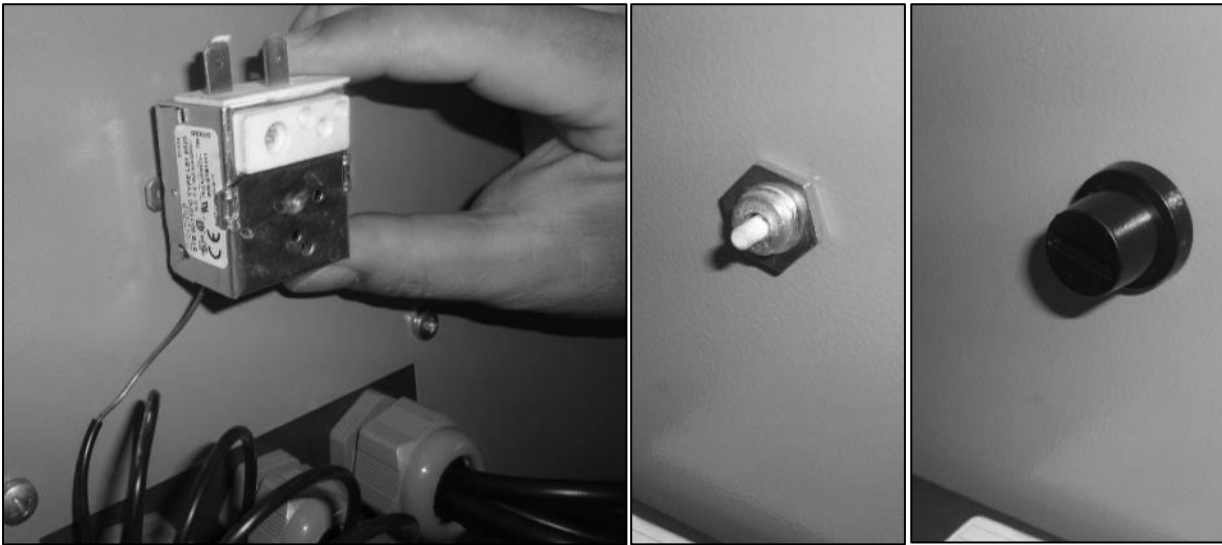

- Attach both ends of safety thermostat wire from control panel onto terminals of safety thermostat as shown in the following picture. Attach sensing bulb of safety thermostat onto boiler hot water outlet pipe, fixing the bulb by the help of the springs supplied together with accessory pack. Attach NTC sensor of boiler thermostat (from control panel) into the pocket phial on top of the boiler body in front of hot water outlet pipe.



NOTICE – Wiring

Note for the wiring indications: Each wiring from control panel has an indication for its related accessory. Please make sure you are making the right connection for the right item

For mains
 For fan
 For pump
 For safety limiter
 For room thermostat
 For DHW pump
 For flue gas
 For door switch

To MAINS
 To CHIMNEY FAN
 To PUMP
 SAFETY LIMIT THERMOSTAT
 ROOM THERMOSTAT
 DHW PUMP
 FLUE GAS
 DOOR SWITCH

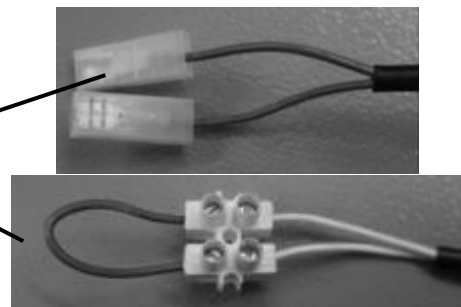

- There are left and right cable canals with openings to the back side of the boiler. These cable canals provide the cables to be related easily to connection points. Draw wirings from the control panel to outboard through the cable canals, Use cable clips and secure the cable and clips together on the

cable canal cover. After that assemble the covers to the casing as shown in the following pictures. If DHW tank is used attach the "DHW NTC" sensor to the DHW tank (enable the DHW function on the control panel - see next chapter)

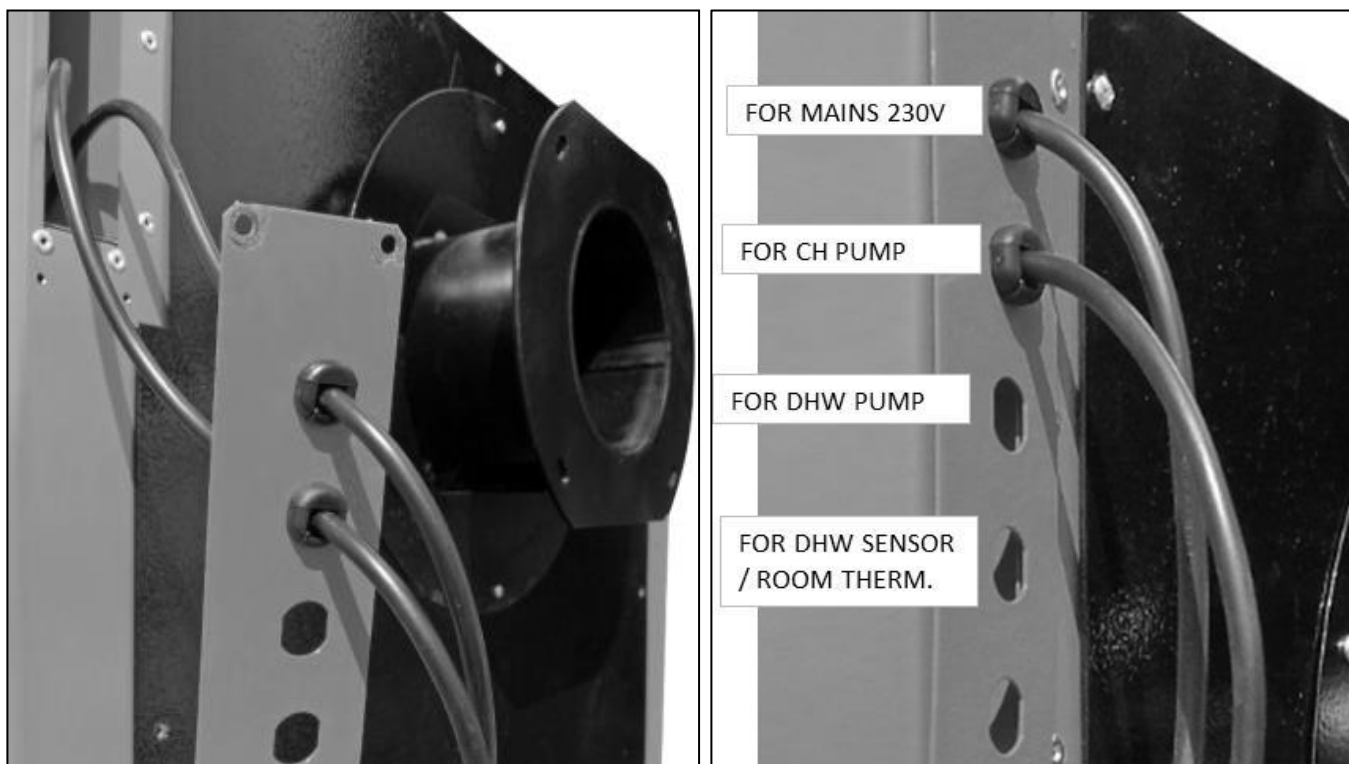

5. Take wiring from the control panel to the fan whose end connected to a female socket. Attach this socket to other cable canal cover, as seen in the following picture. Take wiring from the fan with male socket on its end, and attach this socket to the female one which is fixed to the cable canal cover. When working with flue thermostat sensor, attach a rubber gasket onto cable canal cover, and pass the sensor cable through this rubber gasket before fixing the cable cover to the side panel of the boiler.

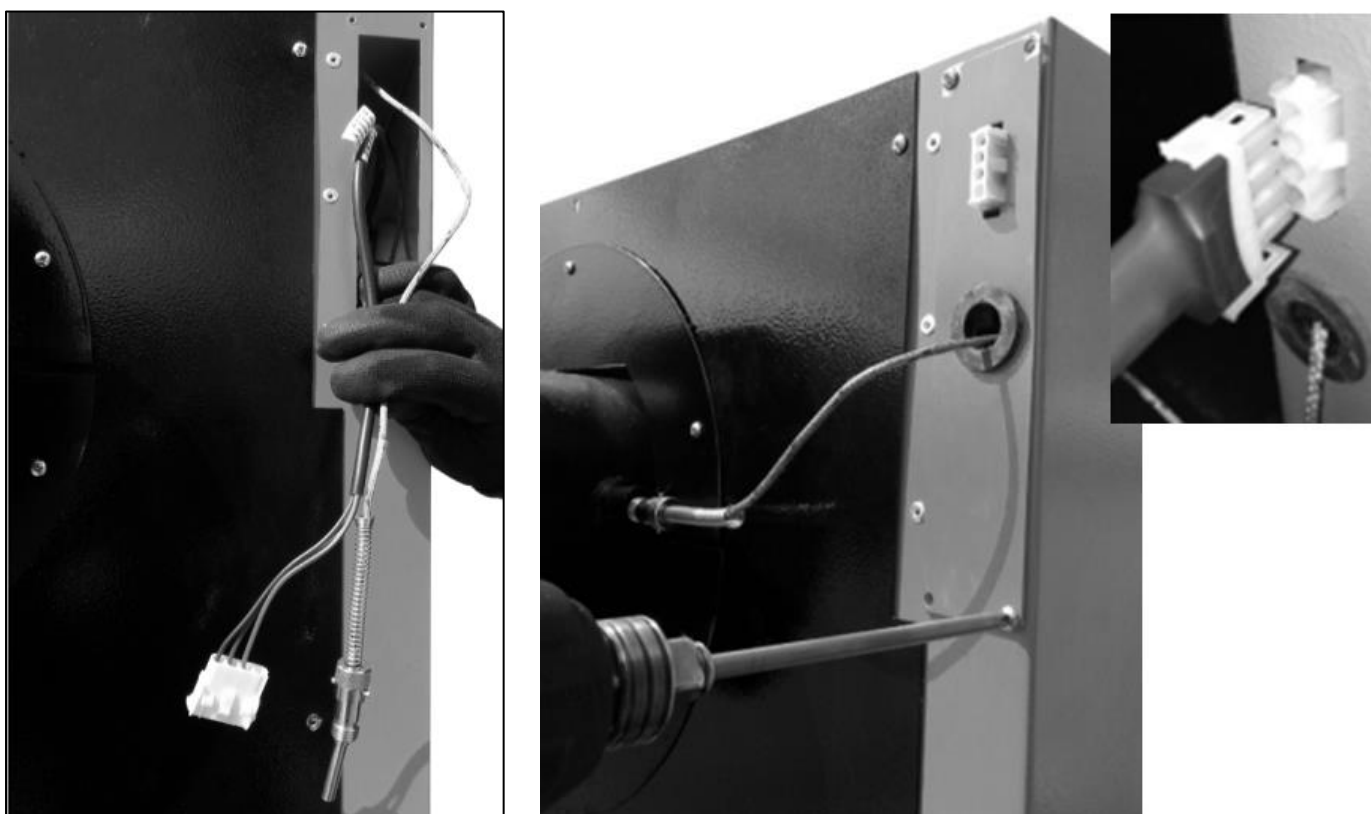

6. Make the door switch electrical connection according to the diagram given below. Be sure that the the switch is mounted tightly and the distance between the door and the roller lever of the switch is enough to push it up. Check it by opening and closing the door.

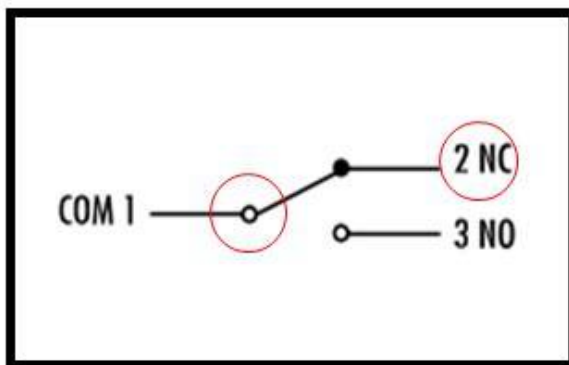

7. Place and secure the top panels into their original places between side panels.

5.9. Suction fan installation

Fix the fan + fan protective shield group on the smokehood as shown in the picture right hand side. Between fan protective shield and smokehood, first place the gasket supplied with the boiler package.

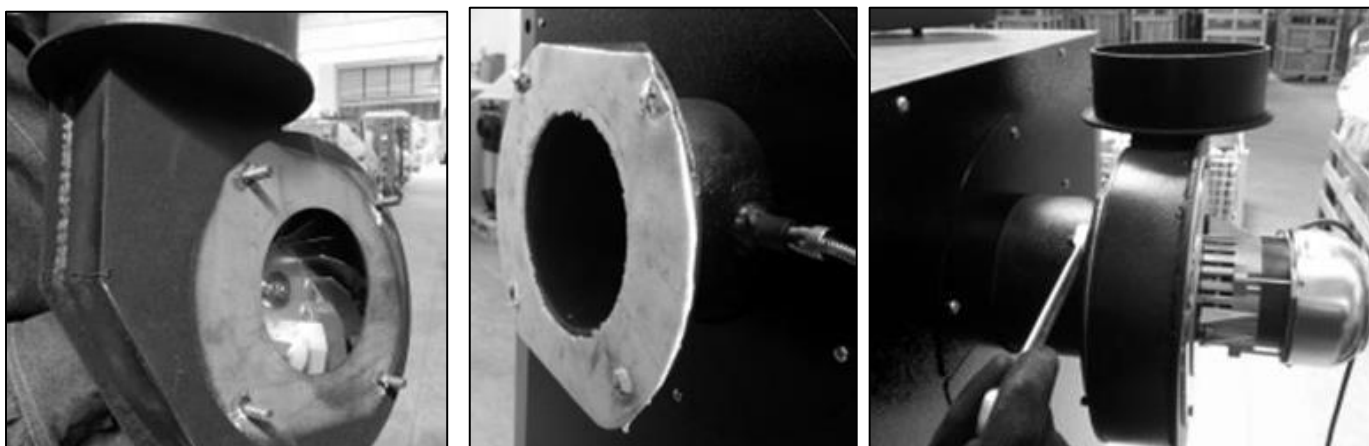

You can choose flue outlet direction during fan scroll installation as seen in the following pictures. Default connection for fan scroll flue outlet is vertical as shown on the left picture. But it is also possible to make horizontal connection for flue outlet:

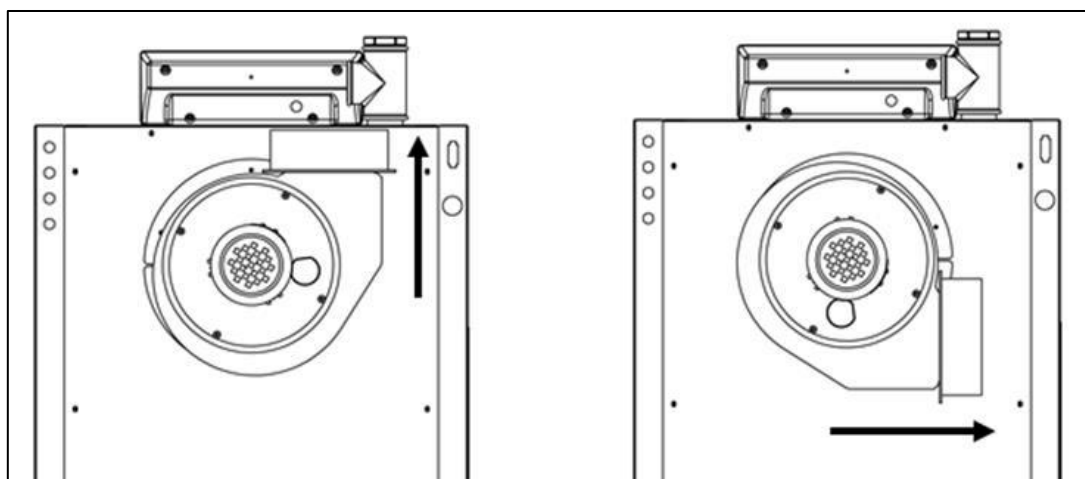

5.10. Flue Gas Temperature Sensor Installation

The thermocouple used in the boiler is "K Type".

1. Remove the flue gas sensor outside through the hole on the side panel (as explained above). Take the pocket phial attached on the flue gas sensor, and screw it into the housing on the fan scroll

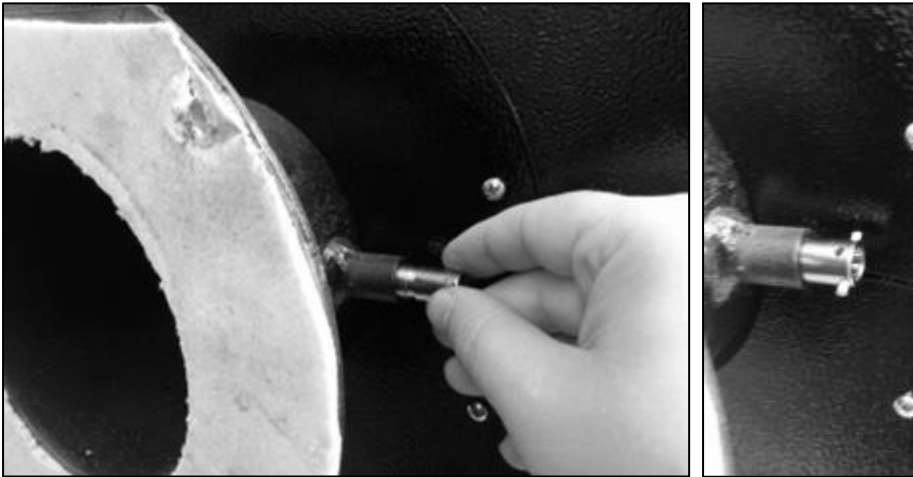

2. By rotating the nut on flexible part of sensor bulb, move the nut away from the sensor head. The distance should be at least 80mm. Then move the sensor into the pocket phial, press and lock the nut to secure both. Make sure that the sensor is mounted tightly.

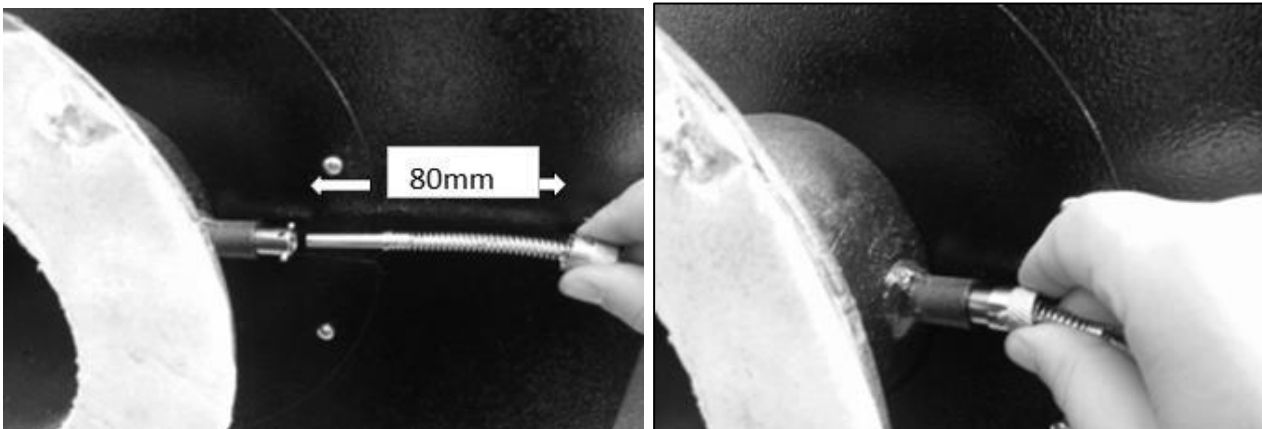

NOTICE – Position of door switch

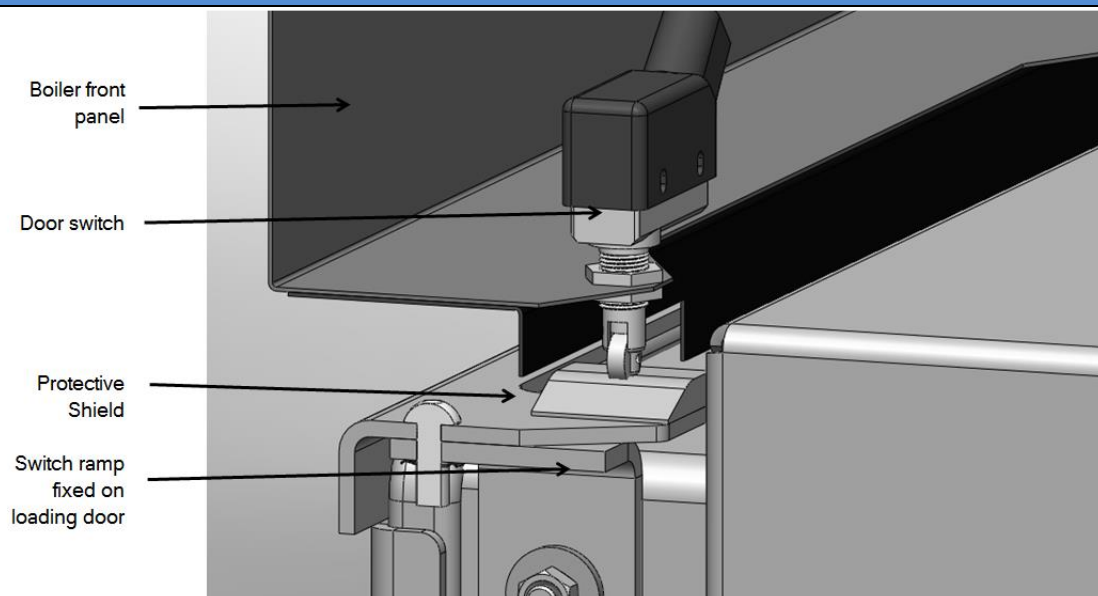

6 OPERATION

6.1 Before first fire make-up

Before the first operation of boiler, the hydraulic circuit must be ready for operation. To fill a pressurised circuit, feed fresh water from main supply line using either filling/drilling tap connection on the boiler back, or the feeding line constructed within the circuit. To purge the air contained in the system, use air relief valves on the hydraulic circuit, on the radiators, and also spring pressure relief valve at boiler hot water outlet. During filling the system all valves and accessories on the lines must be checked for leakage. Before every firing make sure that;

- Boiler and circuit are filled with water, and the hydraulic pressure is in the required range.
- All valves on the line are in open position.
- There is enough draught in chimney.
- There is electricity in front of the control panel inlet. Panel is in STAND-BY mode.

6.2 Firing up

- Before ignition, switch the control panel on by pressing the ON/OFF button at least 3 seconds and adjust the fan 3rd or 4th level. When the control panel is switched ON, fan will not operate, but all safety functions are active. You can operate fan in manual mode by pressing FAN MANUAL button.
- Open fuel loading (upper) door. Through the upper door, put small sizes woodlogs on the burner by keeping burner nozzle open as shown in the picture. Then place some cardboard over them. After cardboard put again some small sizes woodlogs. Than fill the rest of loading chamber with firewood up to 5 cm lower of the top of the boiler as shown in the picture and close the upper door.
- Open the Ignition door (middle door) and ignite the cardboard. Keep the ignition door open for about 5 - 10 minutes to have strong fire bed.
- Air flaps for primary and secondary air inlets are behind of front middle panel and they are adjusted in the factory to the default different levels for every models to provide efficient and clean combustion process.
- Press "AUTO" button for modulated operation, or let the boiler in "MANUAL" mode in desired fan stage.

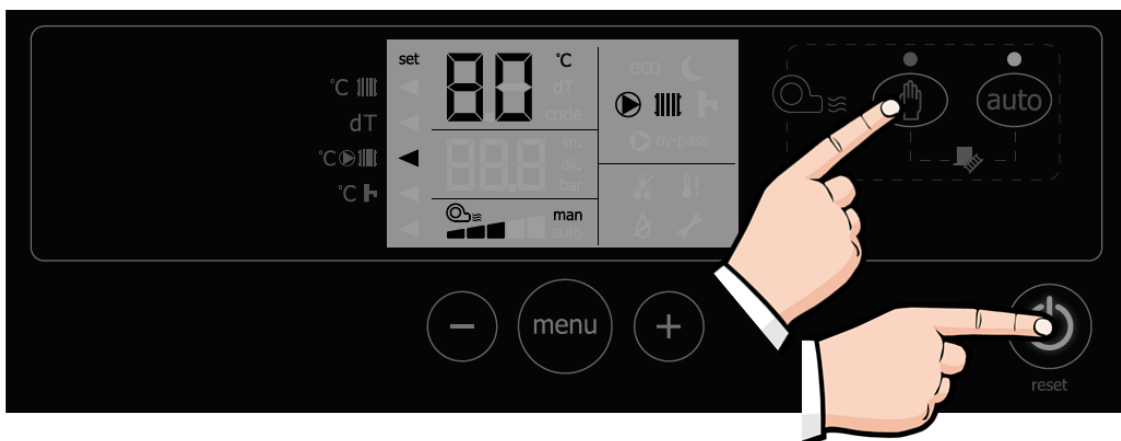
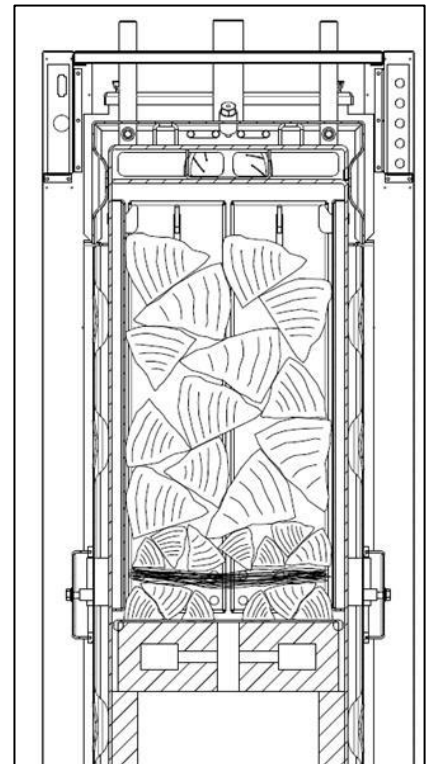

6.3. Door switch function



When the loading door is opened, fan starts running in its maximum speed. On the LCD display the "DR OPN" sign start flashing. Fan can be switched ON and OFF by pressing the "MANUAL" button while the door is open.

6.4. Re-fuelling

Open the middle door and check the fuel in the boiler. If the fuel in the boiler has burned up open the loading door and fill the boiler with firewood and close the door.

WARNING

When re-fuelling, do not open the door completely. First, keep the door little opened for 3-4 seconds to activate door switch and let the accumulated smoke gas leave out the boiler from the by-pass passage. Than open the door completely.

Never open the bottom door when the boiler is operated.

It is important to pay attention on both depth of fuel loading chamber and thickness of upper door refractory while loading the chamber. If wood logs sizes are not matched with the elements mentioned above, it may be difficult to close and secure loading door. Make sure that you close the loading door without applying extra force. Otherwise door itself maybe damaged.

Always use the right size of wood logs when re-fuelling the chamber. For recommended size of fuel, refer to technical data section. When

loading, place the wood logs always align with the depth of the chamber

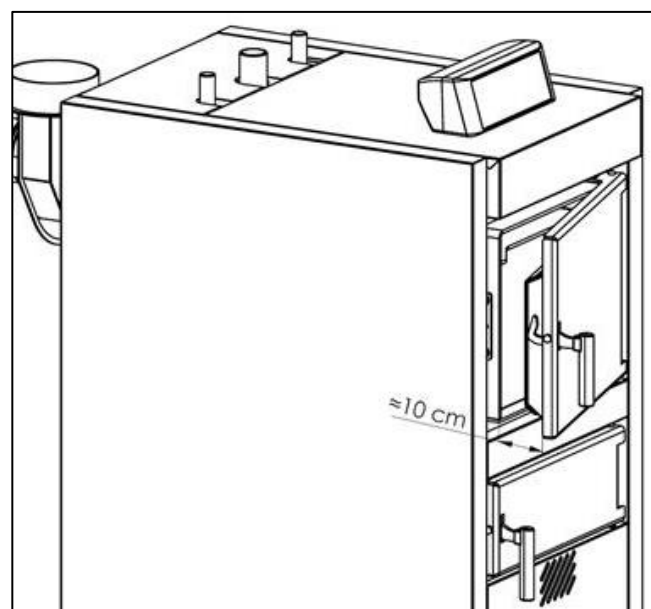

6.5 Control panel user interface

Control panel has following features:

- 1) Displays:
 - a) Actual boiler temperature
 - b) Set boiler temperature
 - c) Fan operation mode and speed
 - d) Circulation pump status
 - e) DHW pump status
 - f) Warning and failure indications
 - g) Set parameters in sub-menus
- 2) Allows adjustment of following parameters in "MENU" mode:
 - a) Boiler set temperature (between 60 to 90 °C with 2 °C intervals)
 - b) Fan speed in manual mode
 - c) Circulation pump switch ON / OFF temperature (if needed)
 - d) Fan safe over-run working parameter (if needed)
 - e) DHW set temperature (between 35 to 70°C with 5C intervals)
- 3) Controls:
 - a) Boiler temperature according to set value
 - b) Auto operation of CH pump
 - c) Modulation of fan speed for optimum efficiency (in "FAN AUTO" mode)
 - d) Room thermostat option
 - e) Auto operation of DHW pump
 - f) Door Switch
- 4) Safety features:
 - a) If boiler temperature reaches up to 100 C for any reason, fan is shut-off, CH pump is kept in operation. Panel warns the user by an audible buzzer alarm. If boiler temperature falls below 95°C again, buzzer alarms switches off, boiler switches back to its normal operation.
 - b) External safety thermostat for additional safety which is activated if boiler temperature is over 110 °C. This thermostat is of manual reset type due to European regulations.
 - c) High current protection fuse, cut outboard on rear panel of the control box.
 - d) When flue gas temperature exceeds the max. setted gasses temperature the fan stops.
 - e) All settings are stored in the memory of electronic board even in case of electricy cut-off
- 5) Energy-saving functions:
 - a) Circulation pump is switched off below boiler temperatures of 60 C. This will also protect the boiler against excessive condensation (this parameter can be re-set)
 - b) Fan speed modulation in respect with desired boiler temperature saves energy and fuel.
 - c) Fan is switched off when there is no fuel in the fuel chamber

6.6 Stand-by mode

When mains is attached, the control panel has following view in STAND-BY mode. Boiler ON/OFF led is on, but no number is shown on the display:

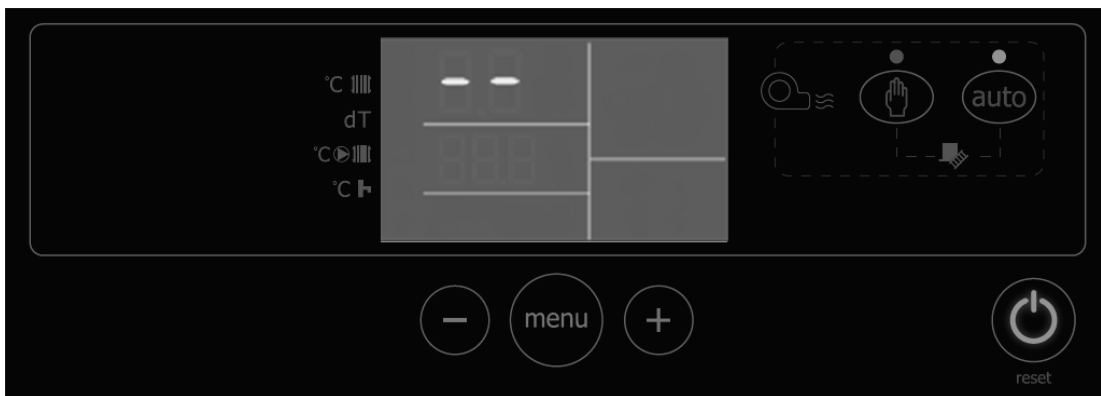

6.7. Operation mode

When loading wood logs and starting fire, you can leave the control panel in STAND-BY mode. When you have continuous flame, switch the control panel on by pressing ON/OFF button.

Fan operation mode setting

You can set the speed of the fan manually at steps, or you can leave fan in "AUTO" mode, in that case, fan speed is modulated by the electronic board in accordance with boiler set and actual temperature. When control panel is switched on, fan will automatically work in the last mode left. By pressing FAN CONTROL buttons "manual" or "auto" you can select in which mode fan will operate.

Fan in manual mode: When this button is pressed, fan will continuously work at selected constant speed:

- If pressed once: Fan will be ON and speed will be at 3rd stage
- Twice: 4th stage
- Third: 5th stage (maximum speed)
- Four times: Fan will be OFF again

Fan in auto mode: When this button is pressed, other mode is cancelled, and fan starts to operate in modulated mode in respect with boiler outlet temperature by the help of written software.

6.8. Boiler outlet water temperature setting



You can set desired boiler outlet water temperature as follows:

- Press MENU button once
- The icon which points the setting parameter will blink
- You can increase or decrease the desired outlet water temperature by pressing the buttons on right or left side of the MENU button



NOTICE

Short-cut for thermostat setting:

You can just press (+) or (-) buttons to set the desired boiler outlet water temperature without entering the MENU.

Boiler outlet temperature can be set between 60 °C to 90 °C, with 2 °C intervals.

6.9. Pump activation temperature setting



Pump starts when the boiler outlet temperatures reaches 60 C, and will stop right below this temperature. We recommend not to change this setting. However if needed this setting can be re-adjusted between 50 and 75 °C by 5 °C intervals. To change this setting:

- Press MENU button three times
- The icon which points the setting parameter will blink
- You can increase or decrease the desired pump activation temperature by pressing the buttons on right or left side of the MENU button

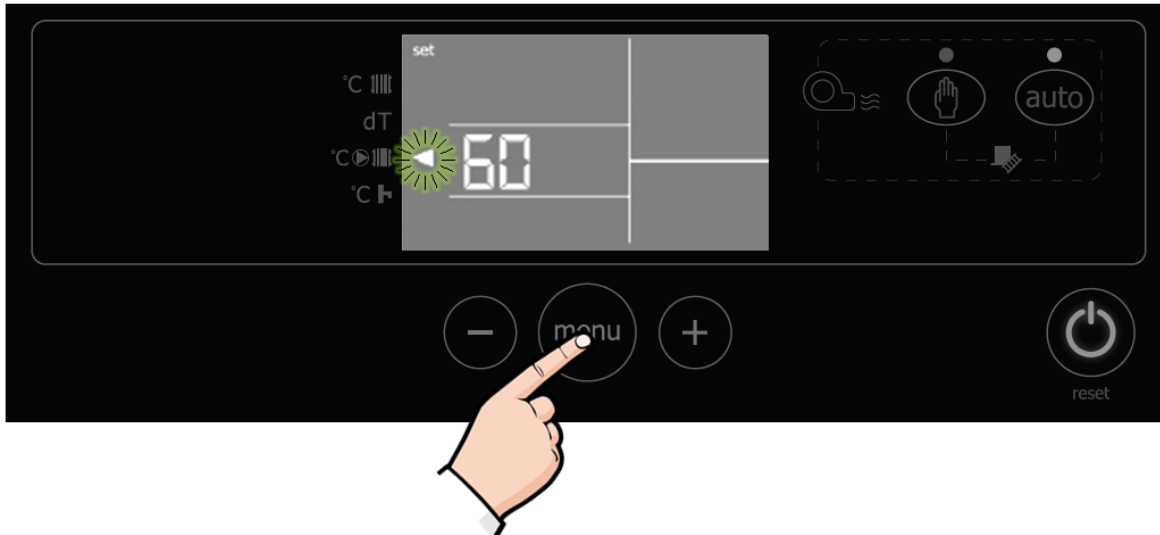

6.10 Auto fan switch-off feature (fan over-run safety time)



When the power is turned on by pressing ON/OFF button of control panel, fan does not start no matter what the boileroutlet temperature is. Fan only starts when you activate it by pressing AUTO FAN buton or MANUAL FAN button, and the fan ledis lit. If you would like to stop the fan, you should press MANUAL FAN button till the fan logo and the speed bars disappear or switch off the panel.

If boiler outlet temperature falls below 60 °C, electronic board keeps on operating fan as long as a pre-set safety timeis elapsed. If boiler temperature does not exceed 60 °C again during this safety time, then control panel assumes thatthere is no fuel in the loading chamber, and fan will be switched off.

After this safety time, if boiler outlet temperature is over 60 °C again for any reason, fan will be kept switched on. Thissafety over-run time is set to 45 minutes at factory outlet and can not be changed by the user.

NOTICE

If boiler temperature does not exceed 60 °C again during this safety time, then control panel assumes that fuel is consumed in the loading chamber. Control panel warns the user by "NO FUEL" indicator on the LCD. Here, you should reset the control panel by pressing ON/OFF button once in that case.

There is a second control algorithim stored on PCB to make sure if fuel is fully consumed or not. Accordingto this control, if boiler outlet temperature falls 20 °C below the desired outlet temperature set by user withinthe same safe over-run time (that is 45 minutes), fan is switched-off. This control function has been addedto PCB's memory, assuming that boiler is always set to high outlet temperatures due to working principle of a gasification boiler.

To give an example for this control function; let us say that outlet temperature is set to 90 °C.

- Fan is switched on, when you press the fan ON/OFF button.
- Pump starts, when boiler temperature exceeds 60 °C.
- When boiler temperature falls below 60 °C, safe over-run time starts to count (45 min).

- After safe over-run time is elapsed, if boiler temperature is not over 60 °C, boiler thinks that, fuel is fully consumed, then, fan and pump is switched-off automatically.
- Within safe over-run time, if boiler temperature is over 60 °C again, the second control function will be in process. As dt=20 °C, if boiler temperature is not over 70 °C (90-20=70 °C) again, boiler thinks that fuel is fully consumed, then, fan and pump is switched-off automatically.

This dt temperature difference can be re-set using menu functions, or this second control function can be disabled if it is not needed. To re-set dt temperature difference:

- Press MENU button two times
- The icon which points the setting parameter will blink
- You can cancel dT parameter, increase or decrease the dT temperature by pressing the buttons on right or left side of the MENU button

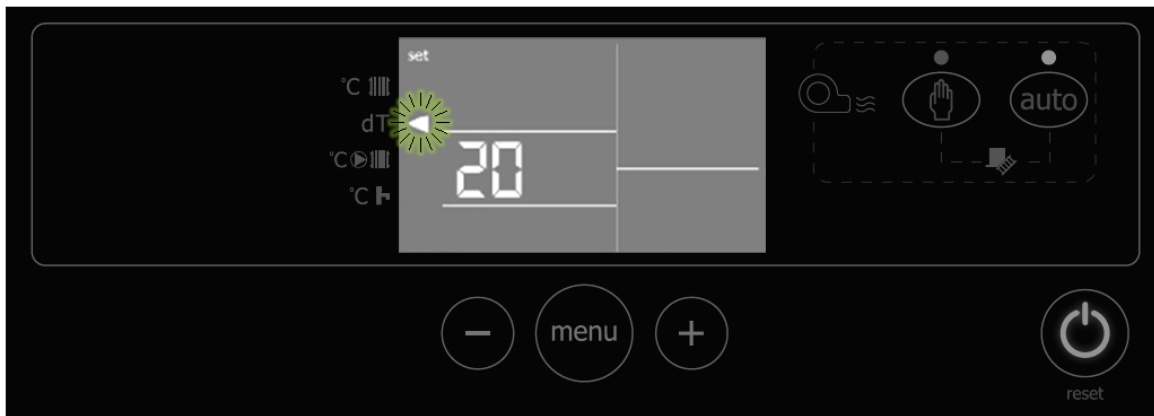

Display view

Meaning

- 0 dt function is disabled (no second control feature for fan switch-off function)
- 5...30 dt is adjusted between 5 to 30 °C by user

NOTICE

Factory setting is 20 C for dT parameter.

If you press MENU button once again, actual setting will be over, and the menu switches to the next set parameter sub-menu. Control panel leaves the MENU mode if you wait for 10 seconds without pressing any button, and goes back to normal operation



6.11. Domestic Hot Water (DHW) Temperature Setting

1. Press MENU button four times
2. The icon which points the setting parameter will blink
3. You can increase or decrease the desired temperature by pressing the buttons on right or left side of the MENU button
4. Temperature can be adjusted between 35-70°C.
5. Default setting is "0".
6. If "0" is selected the DHW function is disabled.
7. If the values between 35-70 is selected the DHW function is enabled.

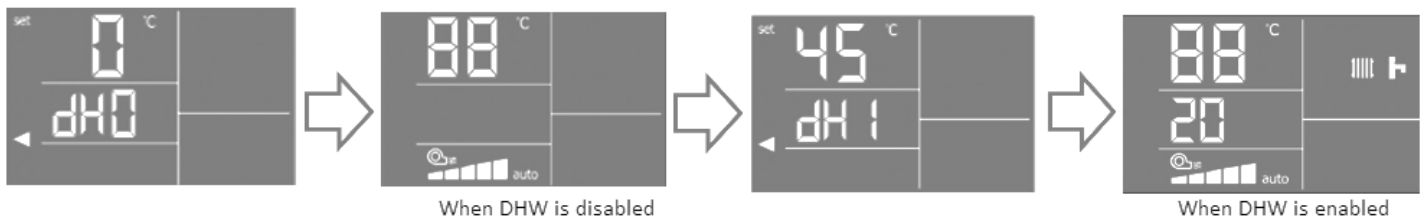

NOTICE

- DHW pump has the priority over the CH pump. When the DHW pump is running the CH pump stops circulation.
- If you press MENU button once again, actual setting will be over, and the menu switches to the next set parameter sub-menu. Control panel leaves the MENU mode if you wait for 10 seconds without pressing any button, and goes back to normal operation
- The DHW pump starts circulating when the boiler temperature is over 60°C.

6.12. Summer / winter mode selection

1. Press MENU button five times
2. The screen shown below will be displayed. You can make selection by using the (-) and (+) buttons.
3. Default value is "00", Winter mode.

Winter mode:

- * Boiler operates on the adjusted boiler set temperature.
- * Central Heating (CH) pump is enabled.
- * DHW pump is enabled, if "dH1" is selected.



Summer mode:

- * Central Heating (CH) pump is disabled
- * DHW pump operates on the adjusted DHW set temperature, if "dH1" is selected.
- * If "dH0" is selected the DHW pump will not run also in the summer mode.



6.13. Flue Gas Temperature Sensor function

When actual flue gas temperature exceeds the desired flue gas temperature, the controller starts to decrease the fan speed to decrease the gas temperature. Vice versa when the gasses temperature falls below the

desired value the controller increases the fan speed. The fan modulates depending on the flue gas temperature to keep the gas temperature between limits. If flue gas temperature exceeds the maximum set value, fan stops running to protect the motor and chimney from over-temperature even if the boiler water temperature does not reach the set value. In that case no alarm is displayed. When flue gas temperature falls below the max.set value the boiler switches back to its normal operation.

6.14 Safety shut-offs

If boiler temperature reaches up to 100 °C for any reason, fan is shut-off, CH pump is kept in operation. Panel warns the user by high temperature icon on LCD and an audible buzzer alarm. If boiler temperature falls below 95 °C again, buzzer alarm switches off, boiler switches back to its normal operation.

If boiler temperature reaches 110 °C, it means that there is a problem on control panel's PCB or sensors. In that case, an additional safety thermostat stops the boiler operation for an external safety. Sensing bulb of safety thermostat is attached on the boiler hot water outlet pipe, under the top panel of the boiler, and its reset button is outboard on top panel under a plastic cap. If boiler temperature is above 110 °C, fan is switched OFF, but pump is kept ON in order to protect the system against very high temperatures. E1 failure code appears on LCD. In this case, we recommend you to call for a service agent to check the control panel and its associated equipments. The safety thermostat is of manual reset type, and therefore it must be manually reset right after the problem is solved. Then the control panel is reset by pressing ON/OFF button once.

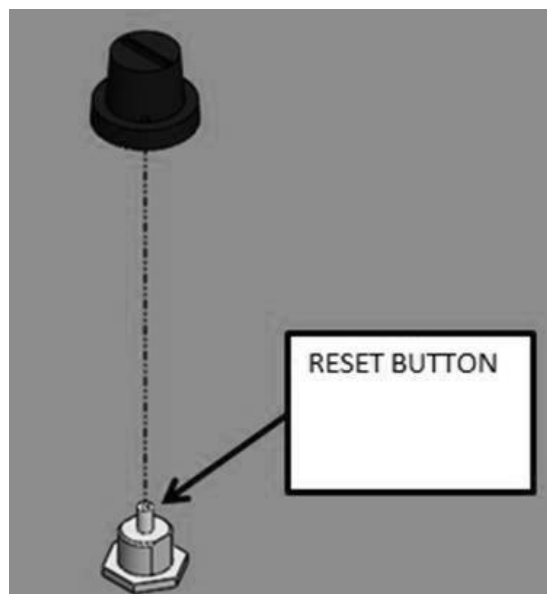

6.15 Shutdown the boiler

Control panel is turned off by pressing ON/OFF button (press and hold the button at least 3 seconds), boiler starts waiting in STAND-BY position.

NOTICE

To stop the fire, set primary and secondary air adjustment knobs to "0"
 Never turn off the control panel when there is fire in combustion chamber.
 After each combustion period, before loading combustion chamber and ignition, the control panel must be reset by pressing ON/OFF button.

6.16 Failure codes and indicators

code E1: High water temperature, safety thermostat stopped the boiler
 code E2: NTC sensor failure
 code E3: Flue gas temperature sensor failure



High temperature warning



No fuel warning



Service required

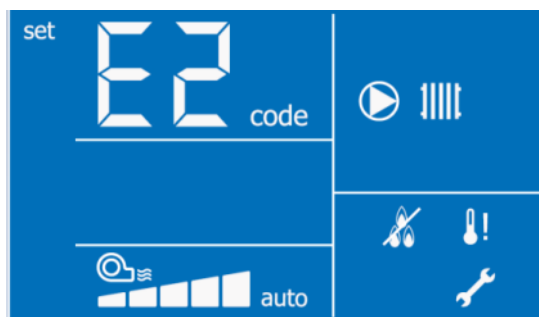

6.17. Room thermostat

You can install a room thermostat between short-cut terminals of room thermostat contact outboard the control panel. If you do not use room thermostat, leave this wire bridge as it is. When desired room temperature is reached:

- * Fan and pump are switched off

- * In the meantime, if boiler temperature exceeds 80 °C, pump will start and, be in operation until boiler temperature is below 70 °C again

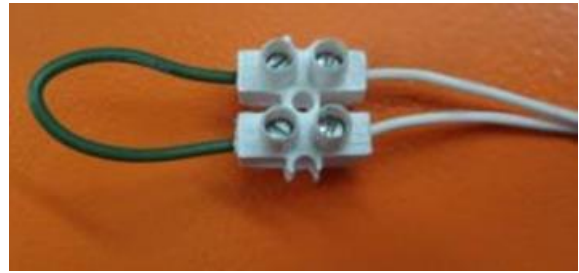

6.18. Primary and secondary air adjustments

Air flaps for primary and secondary air inlets are behind the front middle panel. Primary and secondary air adjustments are set at factory for optimum performance for each model to provide efficient and clean combustion process. Therefore, we do not recommend any change on these settings.

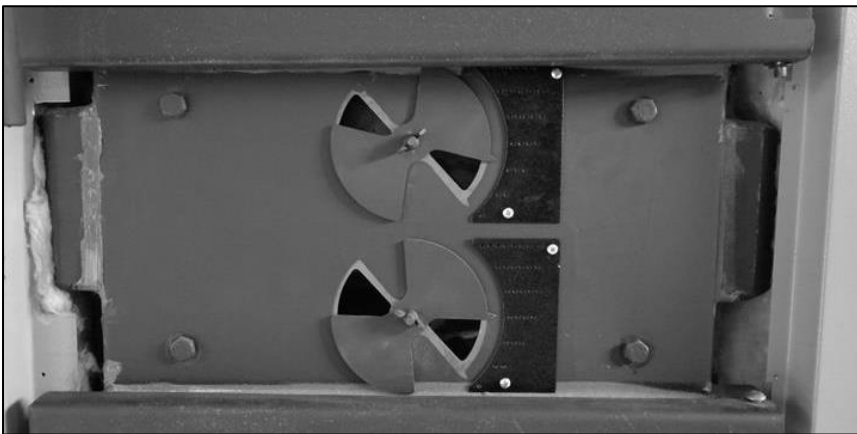

6.19. Chimney Sweep Function (for service purposes only)

This is a function for measuring the emission of chimney. This function is activated by pressing the "auto" and "manual" buttons at the same time for at least 3 seconds. The system is operated for 30 minutes with rated load and then returns back to normal operation. During the operation the both LEDs of the "auto" and "manual" buttons will flash. LCD displays the current boiler temperature and the "CHS" signflashes. To exit this function press the "reset" button. The pump activation temperature for this function is 60°C.



7 HEALTH AND SAFETY INFORMATION

7.1 Control of substances hazardous to user health

For the type of material and where used in your boiler refer to the following chart

PAINTS:	
General purpose black undercoat	NOT APPLICABLE
High temperature black coating	Boiler body
Powder coating	All jackets
INSULATION AND SEALS	
Rock-wool insulation board	NOT APPLICABLE
Glass-wool insulation board	Boiler body
Ceramic fibre rope and tape	Front door
	Burner
Ceramic-fibre board	Front door
CFC free polyurethane spray/foam	NOT APPLICABLE
High alumina cast refractory	Burner
	Ash pan
Asbestos products	NOT APPLICABLE
ADHESIVES	
High temperature adhesive compound	Front door
	Smokehood
	Burner
Fire cement	NOT APPLICABLE
Gas jointing compound	NOT APPLICABLE

Specific data sheets are available on request from the manufacturer for those materials but the following material handling and first aid procedures should in all cases be observed.

7.2 Paints, sealants, ceramic-fibre boards

- These materials contain organic solvents and should be used in a well ventilated area away from naked flames. Do not allow to come into contact with the skin, eyes, inhale or swallow. Use barrier cream or gloves to protect the skin, and goggles to protect the eyes from accidental contact.
- Small quantities can be removed from clothes or skin with a proprietary paint remover or hand cleaning product. If inhaled, remove sufferer into fresh air, if swallowed clean mouth with and drink fresh water but do not induce vomiting. If in the eye, irrigate the eye with clean water and seek medical attention.

7.3 Sharp edges

- Care should be taken when handling sheet metal panels that do not have safety or folded edges

7.4 Lifting boiler body

- Care should be taken when lifting boiler body as they can weigh up to a few hundred kilograms and the manufacturer can confirm the weight of each individual boiler if required

7.5 Thermal insulation

- Avoid contact with skin, eyes or inhaling dust.
- If cutting insulation then do so in a well ventilated area using gloves to protect the hands, goggles to protect the eyes, and a disposable dust mask
- If a skin reaction or eye irritation is experienced then discontinue working with the material and seek medical advice.

7.6 Devices under pressure

- Avoid contact with the parts of heating system under pressure during operation of boiler. These dangerous parts are such that:
 - Boiler body
 - Boiler inlet and outlet lines
 - Safety lines
 - Accumulation tank
 - DHW tank
 - Pressure relief devices installed on heating system
- Never attempt to drain water from heating system when the boiler is being operated
- Never feed the boiler directly with cold water to cool it down for any reason, when the boiler is hot.

7.7 High temperature surfaces

- Avoid contact with parts and surfaces having high temperatures which will be hazardous for human such as:
 - Boiler front doors
 - Water delivery and return lines (even if isolated), safety lines
 - Smokehood
 - Connection between flue outlet and chimney
 - Circulator pumps, expansion vessels

7.8 Boiler room

- Ensure that the boiler room has an easy access to outside in case of danger in heating system. Do not leave the solid fuels and auxiliary substances (chips, paper etc) to ignite the boiler, with the distance less than 800 mm from the boiler
- Do not cover the fresh air openings of the boiler room, as it is very important for the combustion

7.9 Flue gases

- There could be a little gas release from the front side of the boiler, when the front loading door is opened. Never breathe this gas flow.
- When adding solid fuel when there is active fire bed inside the loading chamber, protect your hands and face.
- If needed wear protective gloves.

7.10 Firing fuel

- Do not take the firing fuel out from the loading chamber while it is still burning
- Do not try to put the firing fuel off using water or any other liquids.
- Do not leave the front doors open when there is fire inside the boiler
- Your boiler can only be fired with the solid fuels whose characteristics have been given in Technical data section.
- Never use any other solid fuel that would be harmful for boiler section design, any liquid or gaseous fuels.

8 CLEANING AND MAINTENANCE

Boiler must be cleaned regularly and properly every 3 to 5 days. Because ash settled down inside the ash pan and loading chamber together with condensates and tarr decrease the heat output of the boiler as well as reduce the boiler lifetime due to overheat and damage caused by isolation of heat transfer surfaces.

WARNING

When carrying out cleaning and periodic maintenance, always allow the boiler to cool down sufficiently after being shut down before opening the ash pan door. Always wear heat resistant gloves and protective clothing when handling ash.

To clean the boiler refer to following:

1. First, switch the fan on.
2. Open the upper and middle doors, wipe the ash down through the hole on the refractory burner using cleaning brush supplied with the boiler.
3. Switch the fan off.
4. Close the upper and middle doors, and open front lower door. Remove the cleaning cover on top of smokehood, wipe ashes inside smokehood and smoke pipes down using the cleaning brush supplied with the boiler. All deposits will go down into combustion chamber. Fit the cleaning cover back on its position.
5. Open rear cleaning cover at the bottom. Clean the ash accumulated down inside the combustion chamber (on ash pan, on the lower water heating surface (buffer) and on the bottom) using the ash-shaker supplied with the boiler. Clean all surfaces if there is any tarr accumulation
6. Remove the flue gas sensors and clean the soot on the sensor head. Make sure that the sensor is mounted properly after the cleaning.

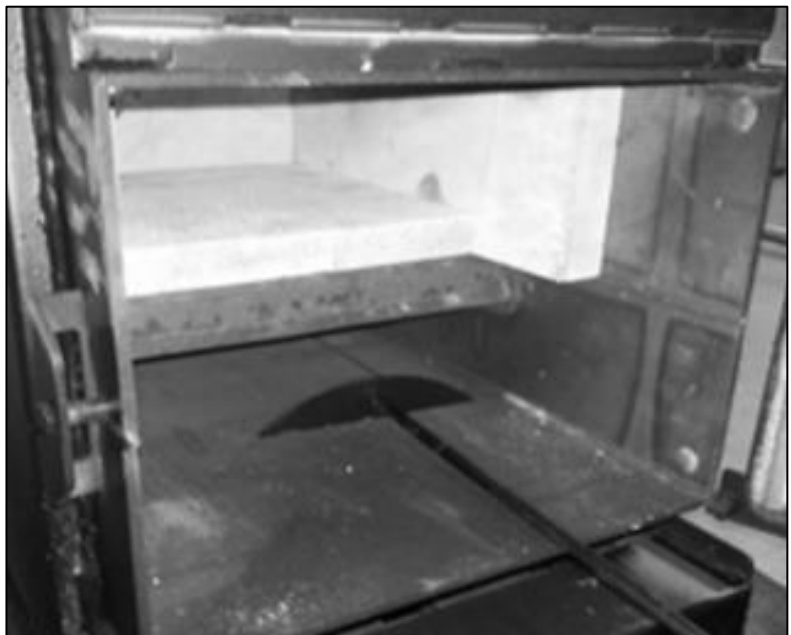

WARNING

Do not move or remove the combustion chamber refractories.

- 7. During gasification process tar occurs, and its quantity depends on wood, its humidity, boiler inlet and outlet temperatures. That is why , fuel loading (gasification) chamber should be cleaned with the scraper at least once a month.

For maintenance;

Before each heating season we would recommend you to call for the contracted service agent to check the boiler, heating system, electrical connections, and chimney conditions. Do not attempt to carry any maintenance work without getting help from qualified people.

Periodic inspections:

- Check the water pressure. If the pressure is under the level of the system set-up, a water make-up is needed. The make-up water should be softened according the local regulations before feeding into the system to prevent corrosion inside the heating circuit and the boiler.
- Exercise the safety relief valve at least once a year
- Front doors of the boiler should be checked for properly closing. Ceramic fibre ropes must be replaced if necessary. When replacing rope, first apply high temperature resistant adhesive onto the surface where you will place the rope.
- Check the condition of refractory inside the front doors. If it is damaged, you will have higher surface temperatures on front doors. In this case the refractory should be replaced to save energy and prevent further crack.
- Check the condition of ceramic-fibre rope around the burner inside fuel loading chamber. Replace if necessary.
- Inspect chimney, flue pipes, flue pipe joints, and flue pipe seals regularly to ensure that smoke and flue gases are not drawn into, and circulated by, your home’s air circulation system. If you observe rust or smoke leakage, replace the pipe immediately.
- Check wiring to control panel, and wiring from control panel to heating circuit pump and fan.
- Check gasket in front of the fan
- Check glass fibre ropes under rear cleaning cover and replace them if necessary.
- Check wiring to boiler and pump

Daily maintenance	Weekly maintenance	Monthly maintenance	Annual maintenance
Checking burner nozzle opening	Removing ash	Cleaning flue gas sensor	Checking primary air openings behind protecting plates
	Checking safety valve and its connection	Cleaning heat exchanger tubes	Cleaning By-pass passage
	Checking the system pressure		Checking fiber rope for door and burner sealing
			Cleaning draught fan wheel

START-UP / COMMISSIONING FORM

1/2

END-USER INFORMATION

NAME / SURNAME	:	_____
ADDRESS	:	_____
CITY / PROVINCE	:	_____
COUNTRY	:	_____
E-MAIL / GSM	:	_____
SIGNATURE	:	_____

PRODUCT INFORMATION

PRODUCT MODEL	:	_____
EXTRAS 1	:	_____
EXTRAS 2	:	_____
INVOICE DATE and NUMBER	:	_____
SERIAL NUMBER	:	_____

COMMISSIONING OF THE DEVICE

DATE OF COMMISSIONING	:	_____
AUTHORIZED COMPANY for COMMISSIONING	:	_____
ADDRESS	:	_____
E-MAIL / GSM	:	_____
SERVISER NAME / SURNAME	:	_____
SERVISER STAMP and SIGNATURE	:	_____

- Warranty period is 2 (two) years, and starts with signing of this document
- One copy of this document shall be handed to end-user
- General checks on next page should be completed for future reference

START-UP / COMMISSIONING FORM

2/2

General Checks	Check	Comments
Wall plug voltage measurement	_____ V (AC)	
There is no damage because of transportation		
Chimney is clean, functioning well and meets the requirements defined in manuals		
Outputs are tested before start-up and working correctly		
Plumbing plant installation is made according to manuals, and necessary sensors are installed		
Optimization for auger / chimney calibration (if needed) is made		
Purchased optional elements are installed correctly, and tested		

End-User Notification	Check	Comments
User is informed about boiler/stove cleaning and service cycles		
User is informed about errors and how to act when they are shown		
User is informed about combustion power selection and setting necessary thermostats		
User is informed about boiler/stove functioning, operating, fuel quality and warranty conditions		

REMARKS / DIFFERENCES

--