



Installation and User Manual



OPTIMA

Dear Customer

Thank you for purchasing OPTIMA solid fuel boiler. This instruction manual is intended to help you install and operate the product safely, properly and economically. Please read this manual carefully before installation and operation of your product, and keep it during the whole operation life. Do not touch or interfere any part of the product other than those allowed. The installation, maintenance and service of this boiler requires skilled technicians. For the installation of the boiler and proper room selection, installation of water circuit, chimney design, this manual and mandatory regulations must be considered.

Carry out maintenance and cleaning work recommended on your heating system at regular intervals. Details can be found later in the instruction manual. By doing this, you will not only be ensuring the operational reliability of your heating system but also its efficient and low-emission operation

Your boiler's output will vary according to volume of fuel load in the upper chamber between 100% of the boiler's rated power and a reduced value, or your heating system may have a lower demand than the boiler can deliver. For this reason we strictly recommend that an accumulation tank is installed. The accumulation tank ensures operational reliability of the appliance and improves heating response and energy saving, ensuring efficient and low-emission operation of your boiler.

1 INTRODUCTION / WARRANTY CONDITIONS

OPTIMA is a welded steel boiler designed for efficient burning of woodlogs to be used in hot water heating installations. Therefore, it can not be used for direct sanitary water supply. OPTIMA fires your fuel with very high water efficiency, saving on your fuel cost. As it can hold high amount of fuel, and the heat exchanger is integrated with ceramic burner and horizontal smoke tubes, it can maintain sufficient outlet water temperatures until all fuel in the combustion chamber is consumed. Your boiler can be used either in forced or natural water circulation systems thanks to its large waterways inside the boiler and medium sized delivery and return connections.

Delivery term: OPTIMA is delivered in one package with insulation boards and external cabinets attached on the boiler. Pack of exhaust fan (fan, control panel, fan scroll, necessary gasket and sockets) is delivered inside the fuel chamber of the boiler.

Optional accessory: A safety heat exchanger kit against overheating should be purchased. This kit holds a copper heat exchanger against excessive heat accumulation inside the boiler, a safety valve to activate the heating system at high water temperatures, and auxiliary accessories for installation. Whether the hydraulic circuit is open vented or pressurised, this safety heat exchanger system should be utilized for meeting the regulations of related European standard for this product, as well as safety of whole heating installation and boiler itself.

Main features and advantages of OPTIMA boiler:

- **Highly efficient heat exchanger design** based on horizontal and vertical multi-pass structure of flue gas channels. Classic combustion with low emissions and high efficiency, complying eco-design directive
- **Large wood charging chamber**
- Available for pressurised circuits thanks to cooling loop connection.
- Changing the door opening direction
- Ash shaking system on grade activated by foot pedal on either side.
- **New two-stage combustion technique:** Gasification of the fuel and subsequent pyrolysis, without any condensation
- **Optimum air regulation:** Thermostatic adjustment of primary air, and manual adjustment of secondary and complementary air volumes help improve efficiency and flue gas emissions with complete combustion.
- **High temperature resistant ceramic nozzle:** Special cast high alumina refractory nozzle with reinforcement additives against thermal stresses and humidity can operate up to 1600 C, and ensures, improving combustion and emissions
- Investment saving technology
- No need for special conditions of woodlogs

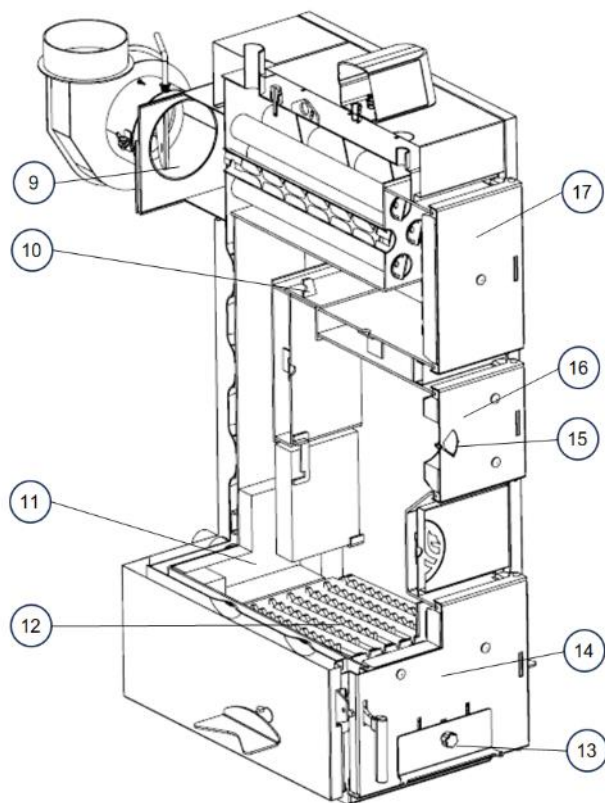
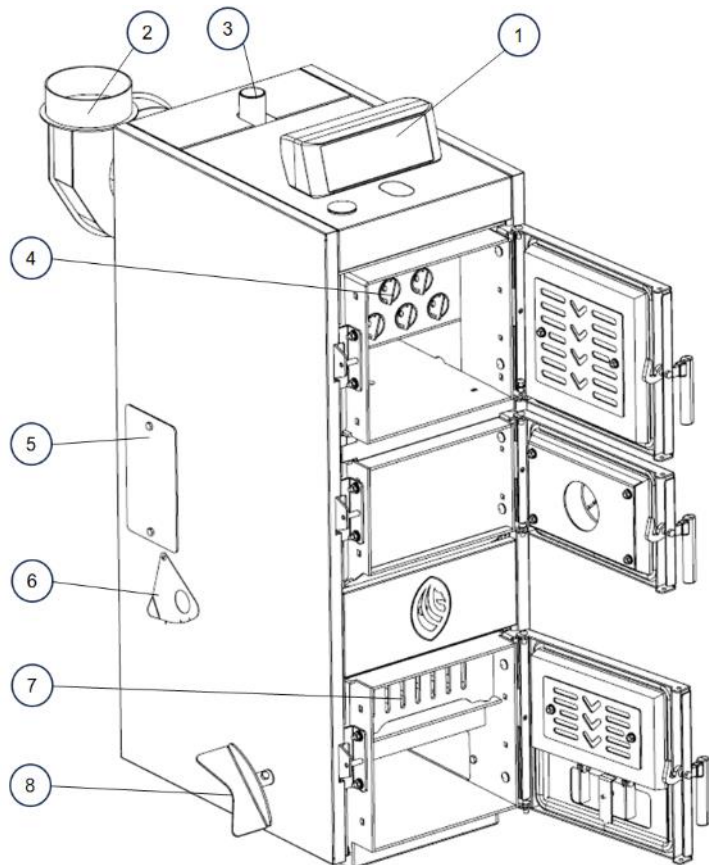

- 1 Control panel
- 2 Fan scroll and exhaust fan
- 3 Hot water outlet (1 ½")
- 4 Smoke pipes with turbulators
- 5 Side cleaning covers
- 6 Secondary air flaps
- 7 Ash door
- 8 Ash shaker foot pedal
- 9 Smoke outlet with damper
- 10 By-pass flap
- 11 Ceramic nozzle group
- 12 Bottom grade
- 13 Regulating air damper
- 14 Ash door (lower door)
- 15 Primary air damper
- 16 Loading door (middle door)
- 17 Upper door
- 18 Port for cooling loop
- 19 Cleaning covers on smokehood
- 20 Cold water return (1 ½")
- 21 Filling / draining (1/2")

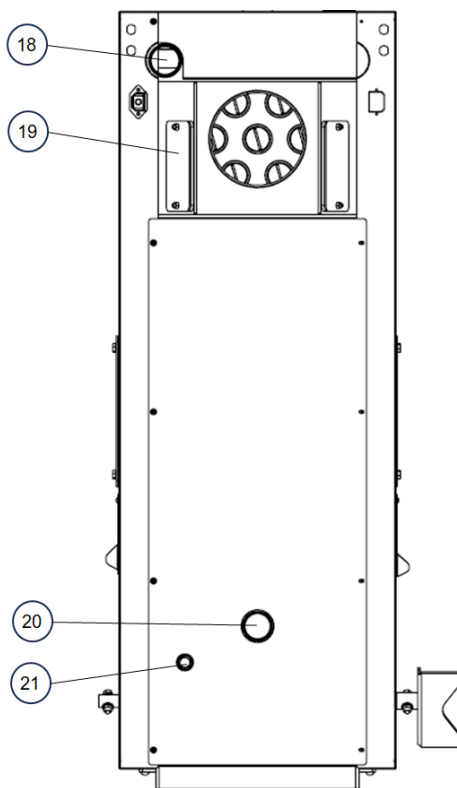

WARRANTY CONDITIONS

THE MANUFACTURER guarantees the product, with the exception of elements subject to normal wear (listed below), for a period of 2 (two) years;

- Starting from date of start-up, which is proven by a commissioning document that contains the name of the seller and the date when the sale / first start-up took place
- If there is no service/commissioning report, standard guarantee period starts with the date when the sale took place.

The term 'warranty' refers to the (free-of-charge) replacement or repairs of parts acknowledged to be faulty due to manufacturing defects.

Furthermore, in order for the guarantee to be valid, the product must be installed and calibrated by qualified personnel. Installations that do not meet the current standards, improper use and lack of maintenance as expected by the manufacturer, void the product warranty. The warranty is valid on the condition that the instructions and warnings contained in this manual are observed, and therefore the product is used correctly.

The replacement of the entire system or the repair of one of its components does not extend the warranty period, and the original expiry date remains unchanged.

EXCLUSIONS FROM WARRANTY

- Parts subject to normal wear such as gaskets, bottom grade, vermiculite boards, fire bricks, fire stone burners, handles and electric cables, knobs, all parts which can be removed from the firebox, are excluded from the warranty
- Any part that may be faulty as a result of negligence or careless use, incorrect maintenance or installation that does not comply with the manufacturer's instructions (see the relative chapters in user manuals of each product).

The warranty will be rendered null and void in the event of damage caused by tampering, atmospheric agents, natural disasters, vandalism, electrical discharges, fire, faults/defects in the electric and/or hydraulic system, and maintenance not being performed at all or as indicated by the manufacturer instructions

Non-regular electrical supplies, and electrical power cuts off too often, can cause severe damage on control system, sensors and actuators of the products carrying those components. We recommend installing 230 V 50 Hz AC voltage regulator for those products. Also installing a UPS for pumps can protect system from electrical cut-offs causing over heating of water.

The warranty does not cover malfunctions and/or damage to the appliance that arise due to the following causes:

- Damage caused during internal transportation and/or handling
- All parts that develop faults due to negligence or improper use, incorrect maintenance, installation that does not comply with the manufacturer's instructions (always refer to the installation manual provided with the product)
- Improper overheating of the equipment, use of fuels not conforming to the types and quantities indicated in the instructions provided
- Further damage caused by incorrect user interventions in an attempt to fix the initial fault
- Worsening of the damage caused by the user continuing to operate the appliance even after the fault has been noticed.
- In case of a boiler/hydro stove, any corrosion, incrustations or breakages caused by water flow, condensation, lack of water in the system, mud or limescale deposits
- Inefficiency of chimneys, flues or parts of the system affecting the appliance.

- Failure to have the annual product maintenance performed by an authorised technician or qualified personnel will result in the loss of the warranty.
- Save for the legal or regulatory limits, the warranty does not cover the containment of atmospheric and acoustic pollution.

THE MANUFACTURER declines all liability for any damage which may be caused, directly or indirectly, to persons, animals or objects as a consequence of non compliance with any provision specified in the manual, especially warnings regarding installation, use and maintenance of the appliance.

SPARE PARTS

Only use original spare parts. The retailer or service centre can provide all necessary information regarding spare parts. We do not recommend waiting for the parts to get worn out before having them replaced. It is important to perform regular maintenance.

The Manufacturer declines all liability if the product and any other accessory is used improperly or modified without authorisation. All parts must be replaced with original spare parts. Warranty cover is valid if the product is installed and tested by a qualified installer, according to the detailed instructions provided in the instruction manual supplied with the product. The term ‘warranty’ refers to the (free-of-charge) replacement or repairs of parts acknowledged to be faulty due to manufacturing defects.

2 SAFETY WARNINGS

3.1 Basic safety instructions

- Never get yourself into danger; give own safety the utmost priority.
- Keep children away from the boiler room and fuel storage room.
- Observe all instructions related to operation, maintenance, servicing and cleaning.
- The heating system may only be installed and started up for the first time by an authorised installer. Professional installation and start up are essential for safe and economical operation.
- Never make any changes to the heating system or flue gas system.
- Never close or remove safety valves.

3.2 Warning signs

DANGER – Risk of poisoning

- Make sure that the boiler is supplied with sufficient combustion air.
- The openings in the combustion air inlet must never be partially or completely closed.
- Ventilation systems, central vacuum cleaning systems, extractor fans, air conditioning systems, flue gas blowers, dryers or similar equipment must never be allowed to draw air from the boiler room and cause a drop in pressure.
- The boiler must be connected tight to the chimney using a flue gas tube.
- Clean the chimney and the flue gas tube at regular intervals.
- The boiler room must be sufficiently supplied with air and ventilated.

DANGER – Risk of electric shock when used with fan

- Switch off the system before performing work on the boiler.
- **THIS APPLIANCE MUST BE EARTHED !**
- Electrical installation of this boiler must be completed in accordance with mandatory regulations, and codes of practice regarding the instructions given in this manual by authorized installator.

DANGER – Risk of explosion / fire

- Never burn petrol, diesel, or other explosive materials in the boiler or storage room
- Never use liquids or chemicals to ignite the wood
- Do not store any flammable materials in the boiler room.
- Do not hang out any washing in the boiler room.
- Always keep all boiler doors closed
- Store the woodlogs in another room, or leave a minimum distance of 80 cm between the boiler and the woodlog pile.

DANGER – Risk of burns

Risk of burns

- Do not touch smokehood, flue spigot or flue gas tube, middle and upper front door surfaces (except for door opening handles and damper), rear cleaning covers named as boiler working surfaces when there is fire, which are marked with red rectangle on the right hand side
- Do not reach or clean the boiler's inside until it has been allowed to cool down.

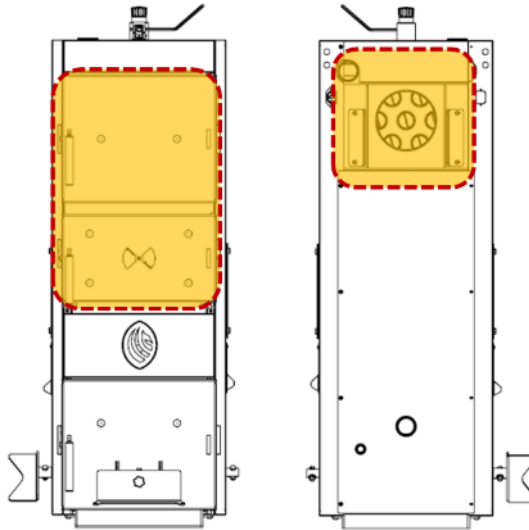

CAUTION – Sharp edges

Risk of cut injuries due to sharp edges.

- Use gloves for performing all work on the boiler.

NOTICE

Damage to property

- Heat the heating system using woods that comply with the specifications below

Damage to property

- Do not use the heating system if it, or any of its components, come into contact with water.
- If water damage occurs, have the heating system checked by your authorised service staff or approved technicians, and have any damaged parts replaced in case needed.

3.3 What to do in an emergency

What to do in the event of a fire

- Switch off the heating system.
- Call the fire brigade
- Use approved fire extinguishers.

What to do if you smell smoke

- Switch off the heating system.
- Close the doors leading to living areas.
- Ventilate the boiler room.

3 TECHNICAL DATA

Model		OPTIMA	
Types		OPTIMA 18	OPTIMA 24
Description of boiler		Welded steel boiler for wood logs with two stage pyrolytic combustion principle	
Fuels		Wood logs	
Output	kW	18	24
Net weight	kg	274	290
Water content	lt	74	81
Total heating surface	m ²	2,30	2,70
Fuel container volume	dm ³	65,0	70,0
Maximum wood log length	cm	33,0	
Fuel loading clearance (H x W)	mm	210x325	210x325
Flue gas temperature	C	< 150	
Required draft at chimney OPTIMA S	Pa	20,0	25,0
Required draft at chimney OPTIMA F	Pa	12,00	12,00
Temperature control range	C	50 - 90	
Maximum operating temperature	C	100	
Minimum return temperature	C	50 (recommended)	
Safety system activated at	C	95 (when used with cooling loop and safet thermostat)	
Maximum operating pressure	bar	2,5	
Water flow/return connections (F/R)	R	1 1/2"	
Cooling loop connections (HE)	R	1 1/2"	
Filling / draining connection (FD)	R	1/2"	
External dimensions			
	H	mm	1220
	H1	mm	210
	H2	mm	270
	W	mm	460
	L	mm	930 (1122 for F type)
	L1	mm	700
	L2	mm	645
	D	mm	160
Electrical supply (OPTIMA F)		230 V / 50 Hz	
Power consumption (OPTIMA F)	W	65	

Fuel type		Wood logs
Combustion period at max load	h	Up to 8 hours
Requested fuel parameters		Allowable water content 12 - 20%
		Average calorific value > 16 MJ/kg
Allowable wood log size		Diameter between 7 cm - 15 cm

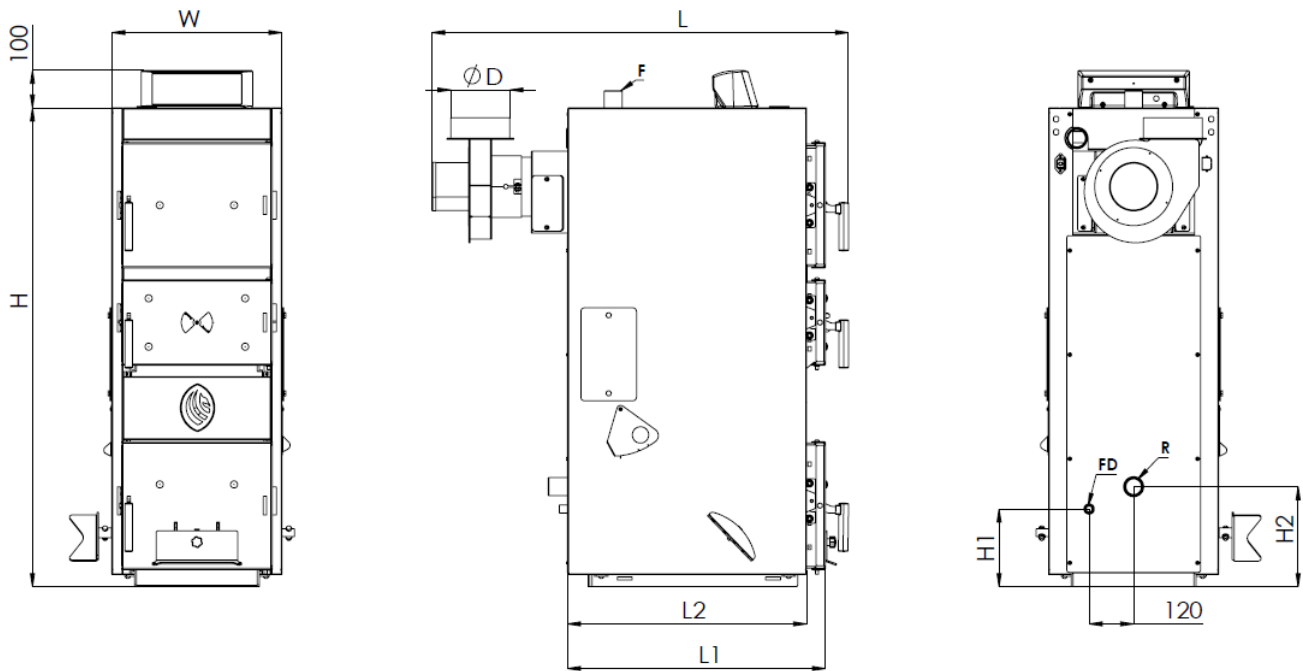

4 WARNING ON BOILER WORKING PRINCIPLE AND PROPER FUELS

Optima boiler is designed for firing of wood logs with length of 33 cm. Wood should be dry or stored in conditions that allow it to dry (away from sources of fire). It is important that thermal value of the wood is primarily dependent upon the moisture content. The moisture of the wood must be between 12 - 20%. Moisture can be measured easily by a simple device purchased commercially. If moisture is above 20%, logs must be dried before use.

Firewood must be split and its size must be adapted accordingly to fit in loading chamber. Unsplit logs and square boards are not suitable for burning. Length of woodlogs should be equal to free length of loading chamber at its best. Bigger logs must be cut into smaller sizes to fit best in the loading chamber. Best way is to split logs before they are prepared for drying.

High moisture content and firing unsplit wood have negative impact on combustion efficiency of boiler and result in higher fuel consumption. The calorific value of firewood should preferably be between 15 to 17 MJ/kg. Suggested fuels:

Wood	Heating capacity for 1 kg		
	kcal	MJ	kWh
Spruce	3900	16,2	4,5
Pine	3800	15,8	4,4
Birch	3750	15,5	4,3
Oak	3600	15,1	4,2
Beech	3450	14,4	4

During operation at low water temperatures, particularly at firing stage, the water vapor contained in the exhaust gases condenses on the boiler walls. During the initial period of use, the above-mentioned condensate may even leak from the boiler onto the boiler room floor. When the boiler has full fire and reaches its optimum heat output, condensation stops, and water contained on boiler walls due to condensation is dried. But prolonged use at low temperatures may cause corrosion and thus shorten the life of the boiler. Therefore, it is not recommended continuous operation of boiler at outlet temperatures below 60°C.

To operate the boiler in safe way:

- Keep inlet and outlet temperatures of boiler at maximum (average should be 60 to 70°C)
- Use dried woodlogs with parameters suggested above

- Load the fuel chamber fully and operate the boiler at declared maximum output. The boiler must not be permanently operated with output levels lower than 50% of its nominal output. Ecological operation of this boiler at its nominal output.
- Use an accumulation tank with a proper size for heat output
- Use necessary means to increase inlet water temperature to boiler in accordance with the instructions given further in this manual.
- Clean boiler surfaces regularly against excessive soot and tar accumulation which will have negative effect on boiler performance

5 INSTALLATION

5.1 Handling the product

Optima is a heavy product, and care should be taken when carrying the boiler to the room where it is going to be installed. The total weight of each boiler is indicated in technical data section. Carrying equipment of the product must be of enough capacity to support that weight. To avoid damage during transport, boiler should be moved with forklift or transpalet. Use the transport feet on the wooden pallets.

NOTICE – Damage to property

- Do not use hard and sharp objects while removing the package around the boiler to prevent damage of the painted jackets.

5.2 Room selection

Boiler must be installed in an individual boiler room particularly organized for heating. The boiler room should be of enough volume for installation, firing, and maintenance of the boiler. There should be enough fresh air circulation for combustion, the chimney design must ensure an adequate draught for related boiler type, and must comply with construction criteria given further in this manual and in mandatory regulations. Your boiler must never be installed in open spaces or balconies, in spaces occupied by people like kitchen, living room, bathroom, bedroom, in spaces where there are explosive and combustible materials.

The boiler room should have air ventilation holes through outside to let fresh air in. One air ventilation hole must be built maximum 40 cm below the level of room ceiling, the other must be built maximum 50 cm above the floor level. These ventilation holes should always be kept open. The upper hole should be at least 40x40 cm in size, the lower hole at least 30x30 cm. All hydraulic and electrical circuits must be arranged by authorized staff in accordance with mandatory regulations specified by legal organizations. Solid fuels should be stored by keeping minimum 800 mm distance from the boiler. We recommend you to keep solid fuel in another room. Boiler should be installed on a concrete plinth made of a fireproof material. For minimum sizes of the plinth, following table should be referred

Model		OPTIMA 18	OPTIMA 24
Plinth height	mm	50	50
Plinth width	mm	650	650
Plinth length	mm	700	700

5.3 Clearances around boiler

At least the following clearances (in mm) should be achieved around the boiler. Door opening direction and bottom grade foot pedal position can be changed to either left or right side of the boiler, according to the shape of boiler room. In that case clearances on both sides of boiler should be regarded respectively to leave enough space for service work.

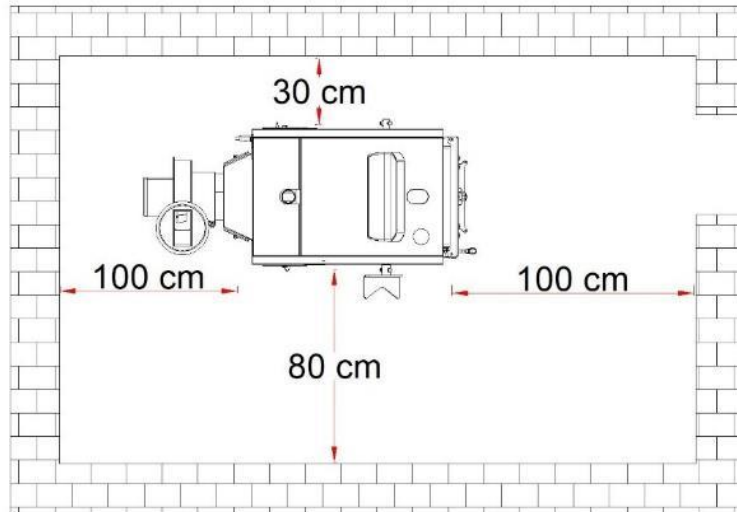

5.4 Circulation pump

We recommend building a forced water circulation system accompanied with a sufficient pump. Refer to the system diagrams given further in this manual to find the right position of the pump within the hydraulic circuit. Your boiler automatically switches the pump on and off according to the program stored in its PCB. That is why circulation pump must be driven by the control panel. Wiring to the pump is supplied at the back of the boiler. The pump will automatically start when boiler outlet water temperature exceeds set value for pump and will automatically switch off when temperature falls below this value. This feature will help prevent boiler from condensation in flue.

5.5 Rules for hydraulic circuit

Boiler at its best should be installed in a pressurized heating circuit accompanied with an accumulation (buffer) tank with addition of a closed expansion tank in respect with the following scheme.

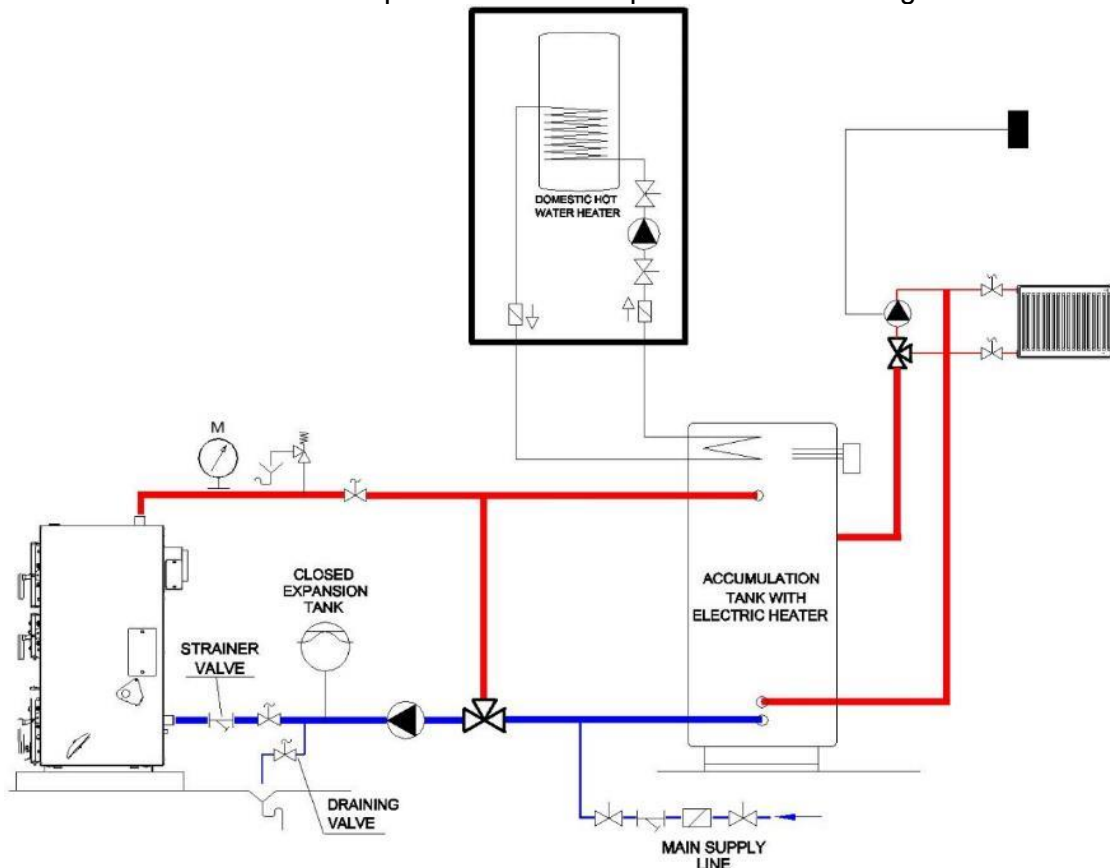

If you install your boiler together with an accumulation tank with a help of a three way valve to increase return temperature to the boiler, you will have higher field efficiency from your heating system installation together with higher comfort and better protection of system components. A thermostatic three way valve sized to

match boiler's delivery rate which is set to minimum 50°C must be added between inlet and outlet lines of the boiler.

We recommend a buffer storage tank capacity of 50 to 70 litres per kW boiler output if the system is based purely on wood and not combined with an oil or gas-fired heating. In any case, this volume should not be lower than 25 litres per kW boiler output.

NOTICE – Safety of heating circuit

- Install a ½" safety valve with a maximum relief pressure of 3 bars.
- Install a manometer to follow and check water pressure in the system. When water is cold, system pressure should be set at 1 - 1,5 bars.

WARNING – Risk of corrosion

- Your boiler is of quite a strong design against corrosion. However, all metal surfaces in whole heating circuit should be protected against corrosion like piping and radiators. The oxygen in heating water will cause rust and then material loss on iron-based metal surfaces by means of oxidation.
- During the first water make-up, oxygen must be fully discharged from the system. Generally, oxidation will not be a problem, if all measures are taken into account during first water make-up. Oxidation will take place because of fresh water addition to the system during operation of the boiler. Leak points in a system will cause oxygen to be absorbed inside the heating water. For this reason, minimum water pressure in a pressurized heating circuit must be above atmospheric pressure. Besides, pressure level should always be checked periodically.

CAUTION – For new installations

- System should be sized and designed accordingly, in order to minimize fresh water addition. Make sure that no part of the system is made of material that is permeable to gases. The original system filling and any topping-up water must be filtered (using synthetic or metal mesh filters with a filtration rating of no less than 50 microns) to prevent sludge from forming and triggering deposit induced corrosion. Minimum water pressure in heating circuit must always be kept above atmospheric pressure

CAUTION – For a new boiler installed on an old heating circuit

- In old systems used for a long time, a protective coating (black magnetite) has been built on all metal surfaces contact with water. This coating protects the system against further corrosion. When a new boiler is installed in such an old system, new parts with clean metal surfaces, particularly boiler surfaces will inevitably become sacrificial anode for the entire heating system, in other words, they come in the first place where corrosion starts. That is why, following precautions should be added to those given above, for a new boiler in an old system:
- If the old system has an open expansion tank, this may be converted to pressurized system with all necessary safety measures.
- The old system must be fully washed up from all substitutes and particules contained on the surfaces.
- An air separator with manual vent should be installed at the highest level of the circuit.

5.5.1. Safety against over-heating

Boiler has a port for installation of optional cooling loop. This cooling loop must be purchased together with the boiler in case of pressurised hydraulic circuit. A safety valve must be purchased separately and installed according to the scheme below:

If the boiler water temperature exceeds 95 °C, thermostat of the safety valve lets cold sanitary water flows through the serpentine of the safety cooling loop. Serpentine with cold water circulating inside cools down the boiler watertemperature. When the boiler temperature decreases below the safe degree, safety valve shuts

the cold sanitary water circulation, and the boiler goes back to normal operation. The valves on the sanitary connections of safety heat exchanger must always be kept open. Cold water must never be delivered directly to boiler inlet in order to solve overheating problems as this will result in serious damage on boiler body. That application will end warranty of the boiler.

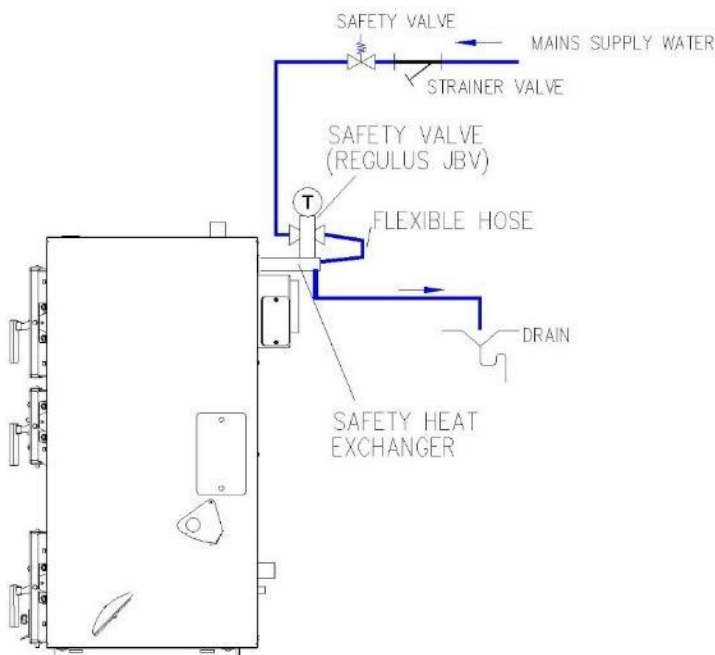

NOTICE

- Cold water pressure for safety heat exchanger must be reduced to 2 bars before safety valve inlet.

5.5.2. Open vented hydraulic circuit

If optional safety cooling loop is not installed, boiler must be connected to an open type expansion tank in accordance with the following scheme. The circulation pump may be installed on either delivery or return line of the boiler

Open type expansion tank must be installed at the highest level of whole hydraulic system. No globe valves must be installed on delivery and return safety lines between boiler and expansion tank. Safety lines should be attached to inlet and outlet lines of boiler at points as close as possible to boiler, using the shortest possible vertical way between expansion tank and boiler. If the circulation pump is installed on return line, and if the head of pump at maximum speed is "h", the vertical distance (h) must be achieved within the system design (h, being the vertical distance between the accumulation tank or top of the radiator circuit and bottom level of open expansion tank). If "h" is not achieved in such system, there will be air suction on radiators at highest level of circuit. In this case, the pump must be installed on delivery line from boiler.

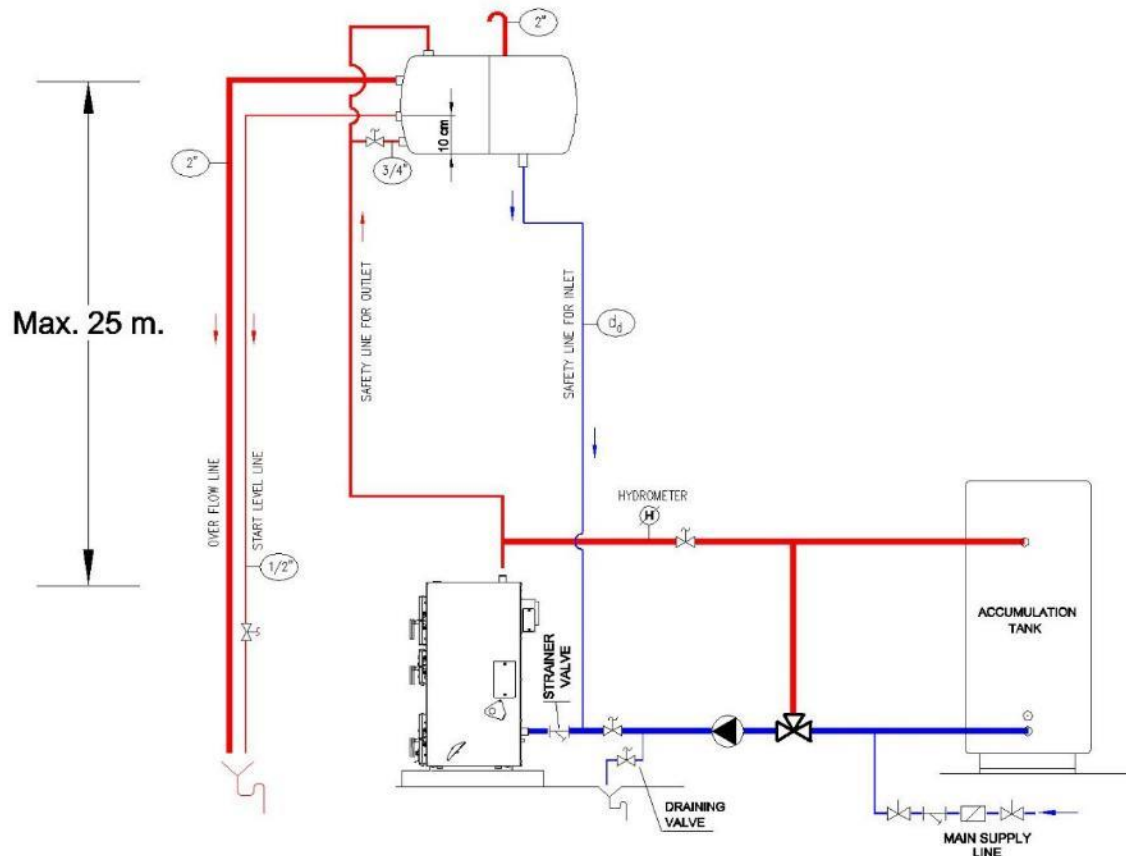

A hydrometer must be installed on the delivery line to monitor the pressure level and to check if there is any leakage. The hydrometer should be purchased separately, and should be installed at the same level with the boiler outlet. A by-pass line should be installed between inlet and outlet connections of circulation pump in order to allow maximum water delivery when circulation pump is switched off and there is fuel fired in boiler, particularly during sudden electricity cuts off.

Design parameters for open expansion tank

Expansion tank protects hydraulic circuit from excessive temperatures by allowing free volume for expanding water and keeping the water pressure from exceeding the static pressure. Expansion tank may be built in rectangular prism or cylindrical shape, may be installed in horizontal or vertical position in the system. Safety lines between boiler and expansion tank should be installed by an increasing slope up to tank.

The size of expansion tank can easily be calculated regarding the total expanding water contained in whole system. If the total volume of water in the system is V_s ; the volume of expansion tank should be:

$$V_g = 8 \cdot V_s / 100 \text{ (in litres)}$$

In more practical way, just using the nominal heat output of boiler (Q_k) in terms of kW, the volume of expansion tank can be calculated as;

$$V_g = 2,15 \cdot Q_k \text{ (in litres)}$$

Size of the safety line for delivery (in mm)

$$d_{SV} = 15 + 1,5 \cdot \sqrt{Q_k}$$

Size of the safety line for return

$$d_{SR} = 15 + \sqrt{Q_k}$$

where Q_k is the boiler output in kW.

5.6 Chimney connection

Your boiler must be connected to an individual chimney that will provide at least the minimum draught requested. The flue canal between the boiler and the chimney should be insulated using a glass wool material. The flue canal to chimney and chimney must be made of steel or an equivalent material that can be used at temperatures around 400 °C.

All connections on flue system must be sealed in order to perform a good combustion and efficiency. The flue canal must be connected to the chimney using the shortest way possible and in accordance with the dimensions given in the following scheme. Horizontal connections and equipments that will increase the pressure loss such as elbows should be avoided. A vertical single steel piping should not be used as a chimney. Chimney must be made of one internal and one external surface. External surface may be made of steel or brick. For internal surface stainless steel chimney elements should be preferred against corrosion. The space between internal and external surfaces of the chimney should be insulated to prevent condensation in flue gasses.

At the lowest level of chimney, there should be a cleaning cover which is made of steel, and sealed for any leakage. The length of flue canal between the boiler and the chimney should not exceed $\frac{1}{4}$ height of chimney.

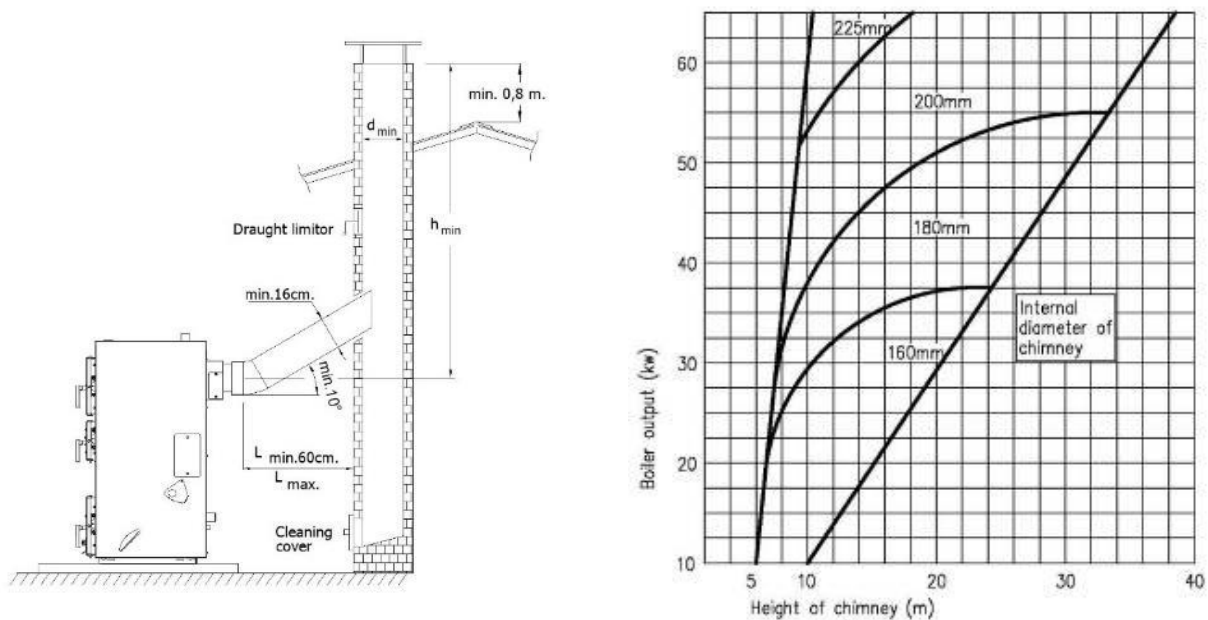

Highest level of chimney outside should be in accordance with the dimensions given in following sketch so as to minimize the harmful effect of flue gasses on ambient, and to improve draught in chimney.

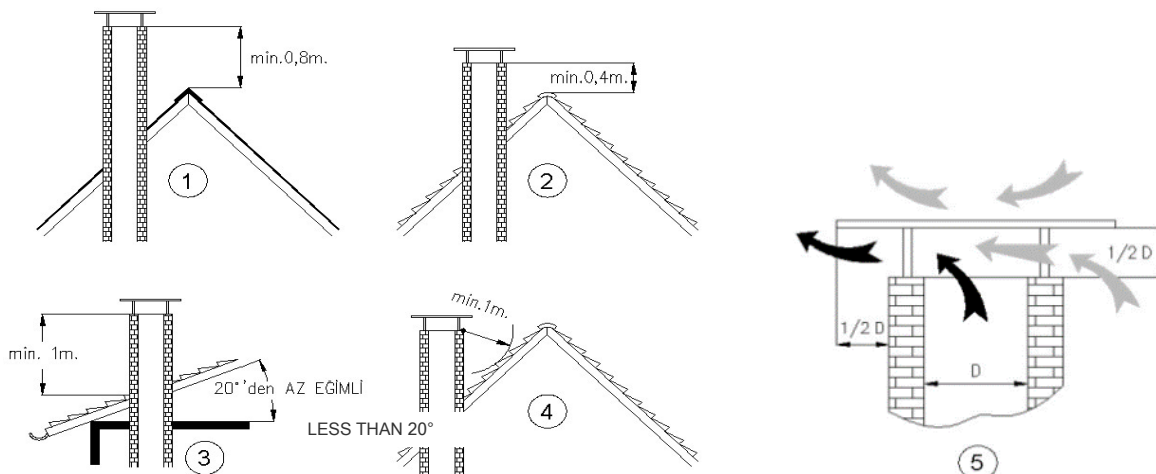

5.7 Installation of safety cooling system

1. Install the safety heat exchanger into the 1 1/2" port on upper left hand side at the back of the boiler. After the installation 1/2" port which is going to be used for safety valve installation should be positioned at the top.
2. Install the Regulus JBV-1 safety valve into 1/2" port.
3. Attach the flexible connection hose supplied with the kit between outlet port of safety valve and one of ports of safety valve in respect with the flow direction shown on safety valve body.
4. Finally, attach cold water supply line to inlet port of safety valve, and drain the other port of the safety heat exchanger.

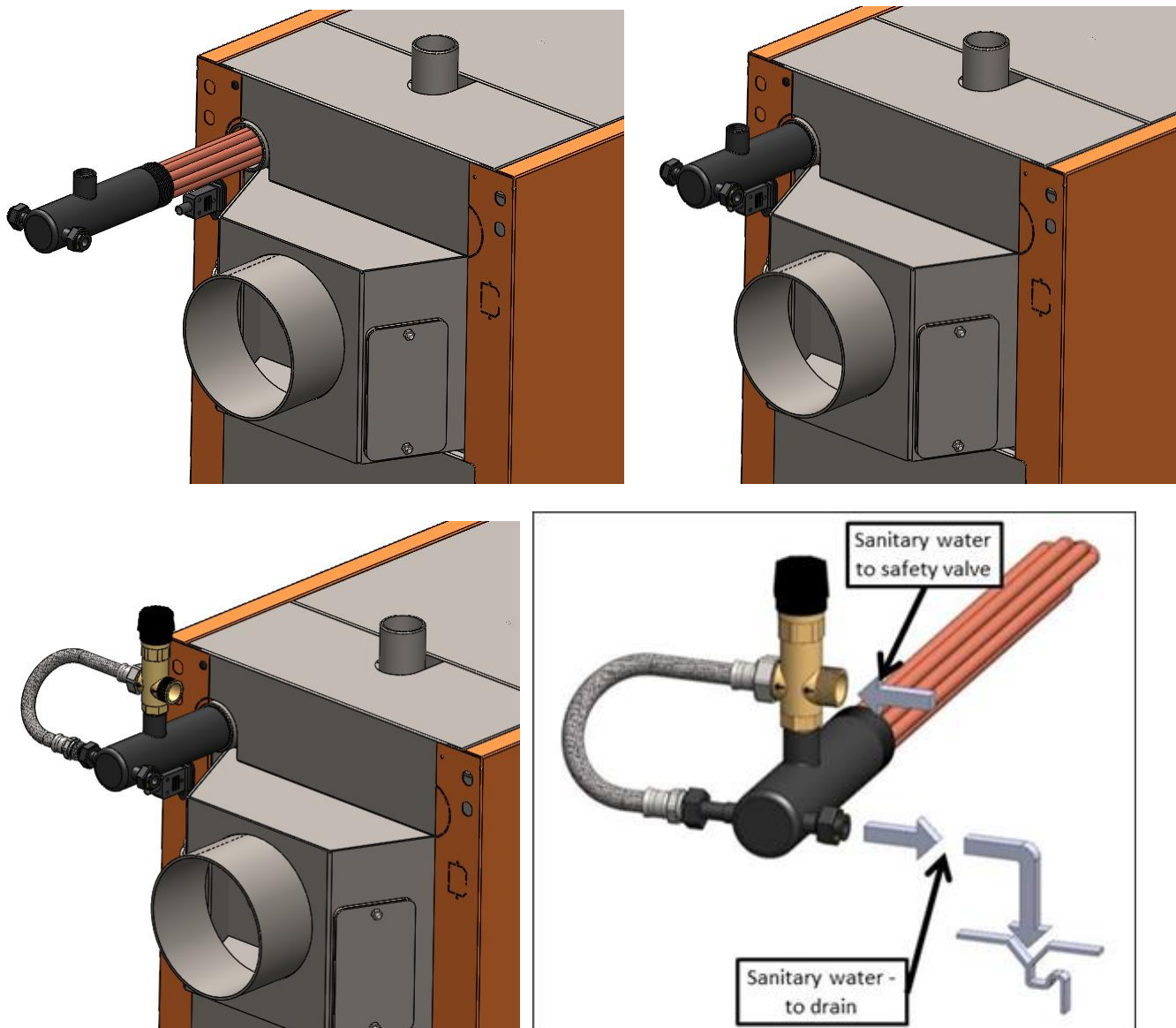

Follow the instructions to finish the assembly of boiler accessories supplied together with the boiler

1. Remove the top panel of the boiler, and install the thermo-regulator into 3/4" port at top of boiler body. Place top panel into its original position, check that thermometer bulb is on the right position, and secure top panel to side panel using the same screws.
- 3.. Attach thermo-regulator arm onto thermo-regulator passing it through the corresponding hole. Then, secure it using the screw on thermo-regulator body. Attach thermo-regulator chain supplied within its package between the end of thermo-regulator arm and primary air entrance damper on front lower (ash) door.

5.8 Electrical installation and wiring complete

The boiler is fed with 230 V. A regulator must be used in installations where the power supply is below 205 V or above 230 V. Control panel should be connected to a wall plug with an efficient ground system, which is placed not far more than 50 cm. to boiler with a circuit breaker which has at least 3 mm gap between contacts. For this reason, if a new electrical installation is required, 3x1,5 TTR cables must be used.

WARNING

All electrical installations must be carried out by authorized persons in accordance with mandatory regulations and codes of practice. Only qualified personnel may open the control panel on the boiler. Any interference with the wiring in the control panel will invalidate the warranty.

Follow the instructions to finish the assembly of boiler accessories supplied together with the boiler:

1. According to boiler position in the room cut the port for fan cable socket out from the rear panel, and fix the male socket supplied with the accessory pack.



2. Attach fan gasket onto the fan scroll, and fix the exhaust fan to the scroll with supplied self tapping screws.

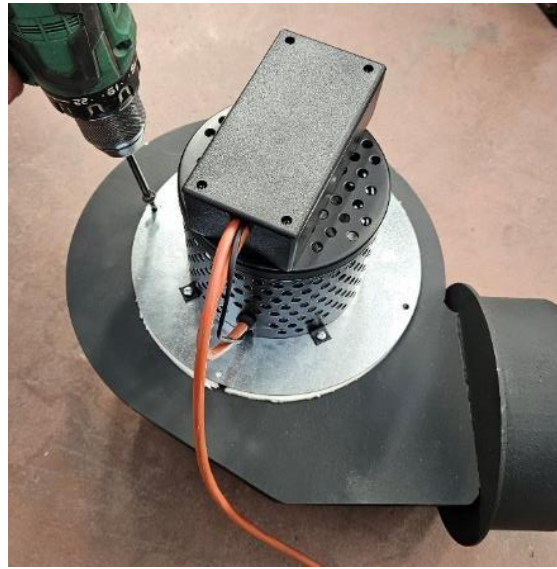

3. Remove top panels starting from the rear part of top panel as shown in the following sketches:

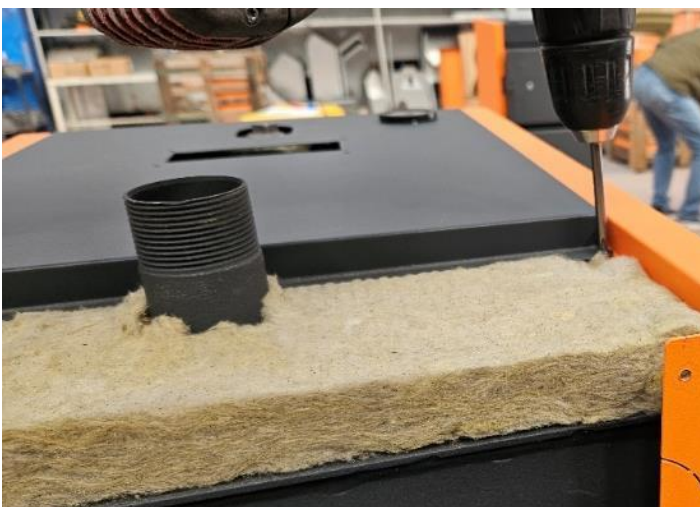
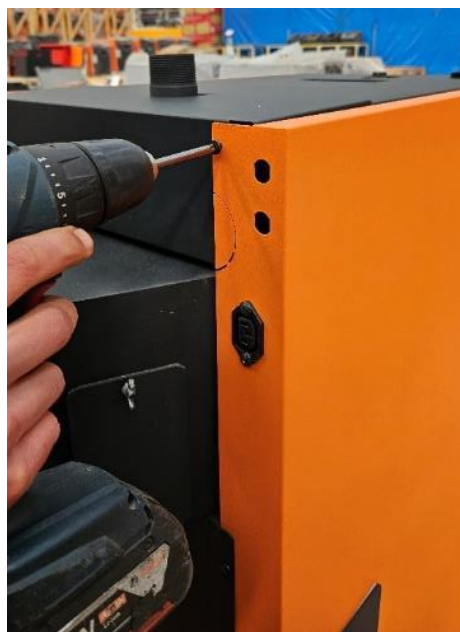

4. Before fixing the control panel to top jacket, draw all wires and sensor cables from the panel through the holes on top panel. Fix the control panel to jacket by using four pieces M5 setcrews supplied with the boiler.



5. Attach STB thermostat onto the water outlet pipe securing it with the supplied special spring, as seen in the following pictures:



6. Fit boiler thermostat sensing bulb into the pocket on top of the boiler, next to water outlet pipe, and secure it with the supplied snap ring. Attach wiring ends of STB thermostat onto related terminals.
7. Control panel has outlets for external burner (like pellet burners). As Optima boiler does not have this option, we recommend to block these wirings to the terminal block supplied with the boiler, as shown above



8. Attach isolated terminals of fan wiring to the female plug supplied together with the boiler package. Make sure that you are connecting the right wire to the right terminal on female plug. Follow the matching given in following picture. Fix female plug for fan wiring to the left hand side panel by self tapping screws supplied with accessory pack.



9. Draw wiring to mains and heating circuit pump through cable clips and secure the cable and clips together on the side panel of the boiler as shown on the following picture.



10. Fit exhaust fan and fan scroll group onto the flue outlet of boiler, and secure it as seen in the following Picture. Attach fan plug to the female socket previously installed on boiler external panel.



Notes for wiring:

Wiring type

To the fan
 To the pump
 To the mains
 To bi-metal safety limiter
 External burner (pellet)

Room thermostat

Identification at the end of the wire

FAN / TO BLOWER FAN
 POMPA / TO PUMP
 BESLEME / TO MAINS
 EMNIYET / SAFETY LIMIT THERMOSTAT
 TO EXTERNAL BURNER

ODA TERMOSTADI / ROOM THERMOSTAT

11. To fix foot pedal to activate bottom grate cleaning onto main rod, use the screw and nut, as shown in following picture:

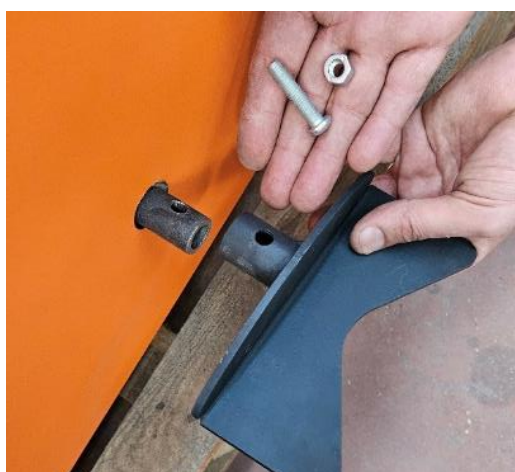

NOTICE – Electrical wiring

- The boiler is fed with 220 V. A regulator must be used in installations where the power supply is below 205 V or above 230 V.
- Control panel should be connected to a wall plug with an efficient ground system, which is placed not far more than 50 cm. to boiler with a circuit breaker which has at least 3 mm gap between contacts. For this reason, if a new electrical installation is required, 3x1,5 TTR cables must be used.
- All electrical installations must be carried out by authorized persons in accordance with mandatory regulations and codes of practise.

THIS APPLIANCE MUST BE EARTHED !

6 OPERATING INSTRUCTIONS

6.1. Pre-firing checks

Before first operation of boiler right after installation, hydraulic circuit must be ready for operation.

To fill an open vented circuit, the valve on start level line from expansion tank is opened, and the circuit is filled with main supply water. During filling the system all valves and accessories on the lines must be checked for leakage. Filling is stopped, when water from start level line is observed, closing the valve on this line. Right after that, hydraulic pressure is marked on screen of the hydrometer. This will make re-filling operations during heating season much easier, just feeding the system with fresh water until hydraulic pressure on screen reaches the pre-marked value.

To fill a pressurised circuit, feed fresh water from main supply line using either filling/drilling tap connection on the boiler back, or the feeding line constructed within the circuit. To purge the air contained in the system, use air relief valves on the hydraulic circuit, on the radiators, and also spring pressure relief valve at boiler hot water outlet. During filling the system all valves and accessories on the lines must be checked for leakage.

Before every firing make sure that;

- Boiler and circuit are filled with water, and the hydraulic pressure is in the required range.
- All valves on the line are in open position.
- There is enough draught in chimney.
- There is electricity in front of the control panel inlet. Panel is in STAND-BY mode.

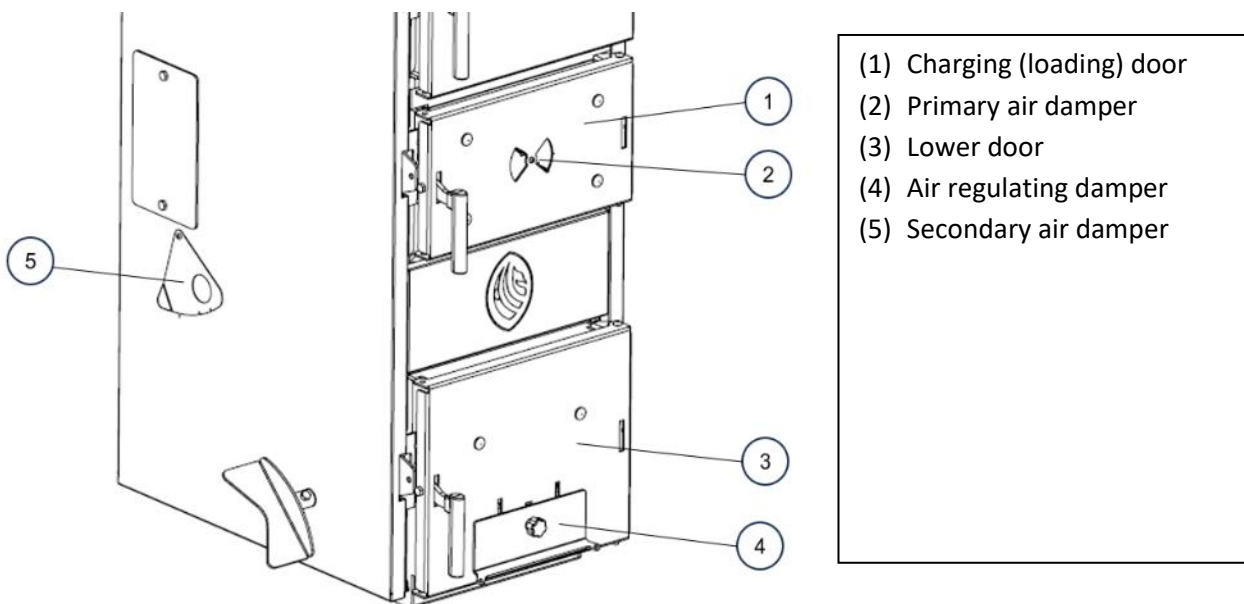

6.2. Firing

Before starting the ignition, fully open the exhaust gas damper in the flue. During ignition, the air supply is provided through the lower door (3) with air regulating damper (4). Set air damper (4) with 20 mm opening clearance and fix this opening with adjustment screw. In order to improve the ignition process, you can open the lower door about 10 cm.

Close the primary air damper (2) on charging door (1), and close the secondary air dampers (5) on both sides of boiler.

Set the kindling. Place fire starters, crumpled newspaper (3 or 4 sheets balled up fairly tightly), and a layer of small pieces of wood, about 10 cm high, on the grate of the boiler to cover the lower opening of the hearth.

Crisscross the kindling so there is plenty of air space in between each piece. Wood that is packed too tight will not burn properly. Then ignite the wood with kindling through the ash door behind the lower door:

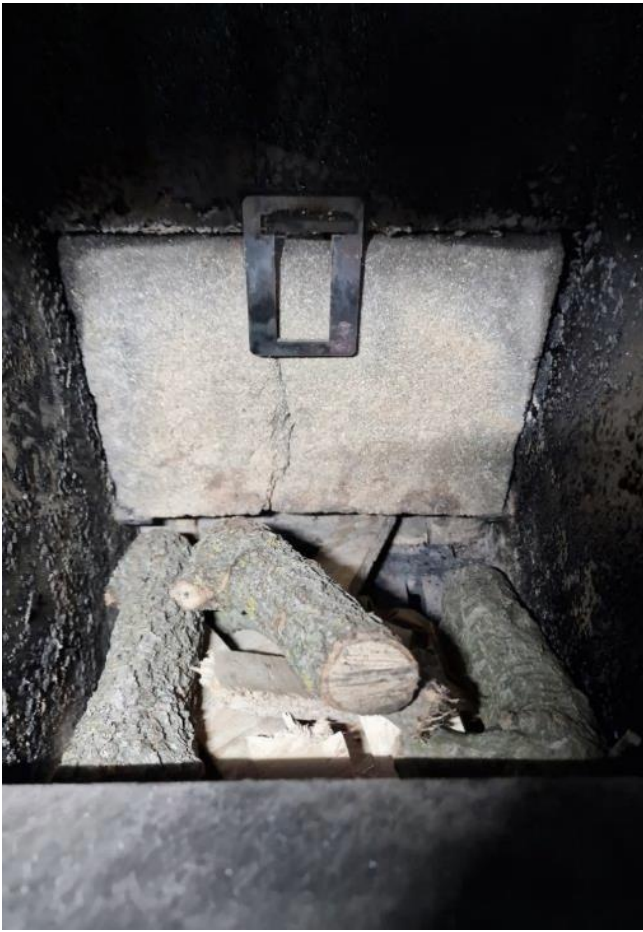

After first ignition, turn on the control panel by pressing ON/OFF button. Follow the instructions in the next chapter given for control panel. During ignition stage, exhaust fan should be set manually to power level 3. After lighting the wood, carefully cover 1-2 layers of woodlogs, so that an ignition layer is formed, close the lower door, and then set the flue damper at the outlet for desired operation (you can adjust the opening of flue damper after several operation for optimum combustion in respect with draught inside existing chimney installation).

When firing up the boiler, keep an eye on it until it reaches a return water temperature of 45° C. This is important because different fuel quality may cause the boiler to go out. In case the fire goes out, clean the furnace, ventilate the boiler channels and start firing up again.

After the ignition layer burns up, fill the combustion chamber up to the lower edge of the charging door. Before filling the chamber with woodlogs, you may use a scraper to push the embers into the rear part of the boiler through the bottom door, if it helps you to get better operation.

Set exhaust fan power level to AUTO. During operation if you have difficulty of warming up, you can switch exhaust fan manually to power level 5. When you have good flame you should switch back to AUTO operation which will help reduce the fuel consumption.

In order to ensure proper operation of the boiler, the secondary air dampers must be opened to approximately half of the opening size. Depending on the quality of the fuel used, the opening size of the dampers should be experimentally determined. They should be positioned in such a way that the flames visible through the holes are slightly deflected, not blown out, and tend to be light yellow, not orange.

Poor illumination of the ash pan by the embers of the furnace indicates that the furnace grate is covered with ash, which is associated with a drop in the water temperature in the boiler. In this case, ash removal from the

grate is done during boiler operation by moving the foot pedal on left or right hand side of the boiler several times.

NOTICE

- During firing up, smoke may enter the boiler room or condensation (sweating) may occur in the boiler. After the boiler and chimney have warmed up, the above-mentioned unfavorable phenomena should disappear.
- Secondary air dampers should be opened when volatile substances are burning in the boiler, i.e. there are long orange flames. At the end of the fuel burning out, it can be completely closed because the "degassed fuel" practically does not need secondary air. But if it is left open all the time, not much harm will happen except a slight unnecessary ventilation of the fireplace.
- For the combustion process to run with maximum efficiency, the fuel bed should be periodically levelled and the combustion grate should be cleaned to remove ash by foot pedal.
- Never set the thermostat lower than 60 C.
- When opening the door, never stand in front of the boiler. This may result in burns.

6.3. Re-fuelling

In order to maintain continuous operation of the boiler, fuel should be added through the charging door. Fuel should be refilled at the latest when the fuel layer drops to the level of the ignition layer, i.e. about 7 cm. If it's less, maybe smoke can occur through the charging door. After charging, in order to remove combustion residues from the grate, press the pedal of the movable grate several times.

Fuel should be added periodically to fill the entire combustion chamber. The fuel supply in the boiler is sufficient for approximately 8 hours. When the boiler operates with lower thermal power, this period increases accordingly.

6.4. Stopping the boiler operation

The boiler is extinguished automatically after fuel burns out, after combustion cycle is completed, the heat exchanger should be cleaned and the boiler grate, and then remove combustion residues from the ash pan

WARNING

- Never let the boiler water temperature reach high values sharply with leaving the pump switched off. In this case, the instant cold water delivery to the very hot boiler may result in cracks on boiler body due to high thermal energy.

6.6. Lack of chimney draught

If there is lack on chimney draught or there is no draught at the chimney (such as badly built, un-insulated, blocked etc.) you may face combustion problems (no fire, excessive smoke, condensation due to cold flue gasses). In this case, we strictly recommend you to have your chimney controlled by an expert, and fix any irregularity.

6.7. Suggested combustion settings:

Air regulating damper on lower door; should be fixed to 20 mm opening. If you have good combustion, you can completely close this damper and fix it.

Primary air damper: At maximum fuel load, it should be set to maximum opening for good combustion and flue emissions. If you have good combustion but need longer operation intervals, you may set it down to 50%, and experience the combustion.

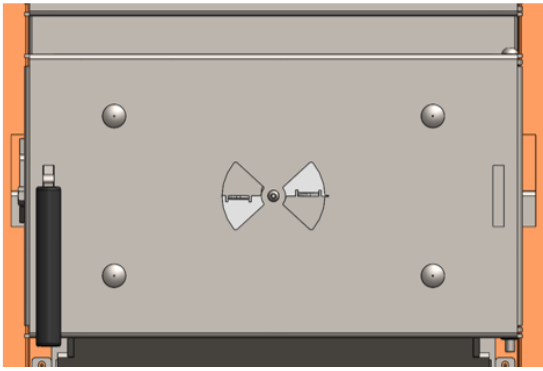

Primary air damper set to 50% opening

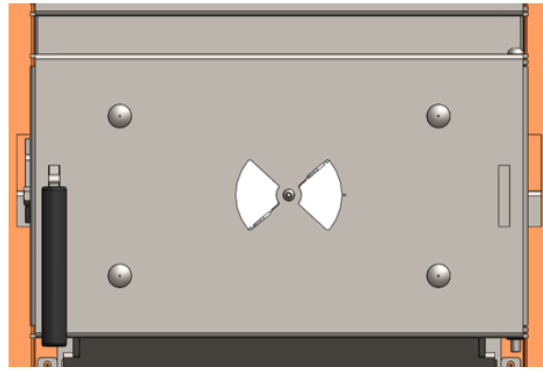

100% opening

Secondary air damper: At maximum fuel load, it should be set to maximum opening for good combustion and flue emissions, or you can experiment this setting based on the information given above.

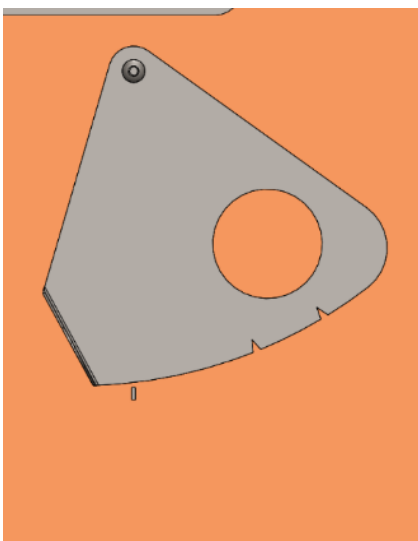

Closed

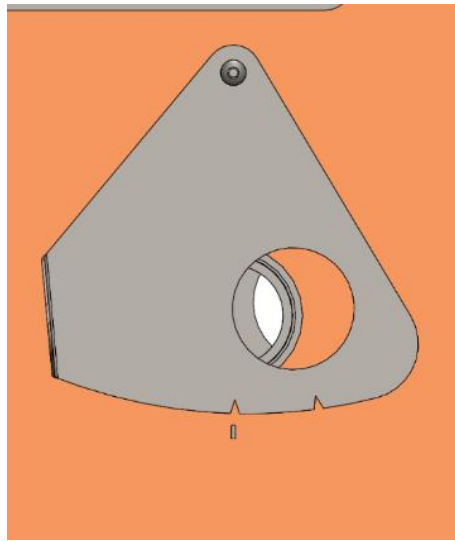

50% opening

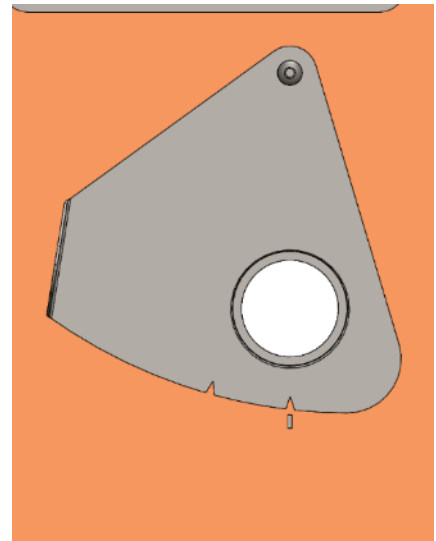

100% opening

Flue damper on the somkehood of the boiler: This damper is useful to adjust draught in the chimney and helps improve the efficiency. During ignition and firing, it should be set to maximum opening. During normal operation of boiler, you should find the best opening of the damper practicing on the boiler.

6.8. Control panel user interface

Control panel has following features:

- 1) Displays:
 - a) Actual boiler temperature
 - b) Set boiler temperature
 - c) Fan operation mode and speed
 - d) Circulation pump status
 - e) Warning and failure indications
 - f) Set parameters in sub-menus
 - g) Boiler operation function (manual, auto, ECO, Night-mode)
- 2) Allows adjustment of following parameters in "MENU" mode:
 - a) Boiler set temperature (between 60 to 90 °C with 2 °C intervals)
 - b) Fan speed in manual mode
 - c) Maximum fan speed in auto mode (if needed)
 - d) Night mode stop and run time re-set (if needed)
 - e) Fan safe over-run working parameter (if needed)

3) Controls:

- a) Boiler temperature according to set value
- b) Auto operation of CH pump
- c) Modulation of fan speed for optimum efficiency (in "FAN AUTO" mode)
- d) Room thermostat option
- e) External burner (preferably as pellet burner) ON/OFF control

4) Safety features:

- a) If boiler temperature reaches up to 100 C for any reason, fan is shut-off, CH pump is kept in operation. Panel warns the user by an audible buzzer alarm. If boiler temperature falls below 95°C again, buzzer alarms switches off, boiler switches back to its normal operation.
- b) External safety bi-metal thermostat for additional safety which is activated if boiler temperature is over 110 °C. This thermostat is of manual reset type due to European regulations.
- c) High current protection fuse, cut outboard on rear panel of the control box.
- d) All settings are stored in the memory of electronic board even in case of electricity cut-off

5) Energy-saving functions:

- a) Circulation pump is switched off below boiler temperatures of 40 °C. This will also protect the boiler against excessive condensation (this parameter can be re-set)
- b) Fan speed modulation in respect with desired boiler temperature saves energy and fuel.
- c) ECO mode automatically shifts set boiler temperature down to 50 C and saves fuel
- d) NIGHT mode keeps the boiler in minimum flame without stopping during the times when there is no need for high temperatures. This will save energy and there will no need to re-fire the boiler in the morning.

6.9. Stand-by mode

When the mains is attached, the control panel has following view in STAND-BY mode. Boiler ON/OFF led is on, but no number is shown on the display:



6.10. Operation mode

When loading wood logs and starting fire, you can leave the control panel in STAND-BY mode. When you have continuous flame, switch the control panel on by pressing ON/OFF button.

6.11. Turning on the panel

By pressing "ON/OFF button" for three seconds, control panel is switched on. LCD display is lit and, actual boiler temperature is displayed. During first ignition, you can run the fan in manual mode. By pressing fan manual button, you can set fan speed at minimum level to help the fire become alive in short time.



6.12. Fan operation mode setting

You can set the speed of the fan manually at 5 steps, or you can leave fan in "AUTO" mode, in that case, fan speed is modulated by the electronic board in accordance with boiler set and actual temperature.



When control panel is switched on, fan will automatically work in the last mode left. By pressing FAN CONTROL buttons "manual" or "auto" you can select in which mode fan will operate.

Fan in manual mode: When this button is pressed, fan will continuously work at selected constant speed:

- If pressed once: Fan will be ON and speed will be minimum
- Twice: 2nd stage
- Third: 3rd stage
- Four times: 4th stage
- Five times: Maximum speed
- Six times: Fan will be OFF again

Fan in auto mode: When this button is pressed, other mode is cancelled, and fan starts to operate in modulated mode in respect with boiler outlet temperature by the help of written software.

6.13. Boiler outlet water temperature setting



You can set desired boiler outlet water temperature as follows:

- Press MENU button once
- The icon which points the setting parameter will blink
- You can increase or decrease the desired outlet water temperature by pressing the buttons on right or left side of the MENU button



NOTICE

Short-cut for thermostat setting:

You can just press (+) or (-) buttons to set the desired boiler outlet water temperature without entering the MENU.

Boiler outlet temperature can be set between 60 °C to 90 °C, with 2 °C intervals.

If you press MENU button once again, thermostat setting will be over, and the menu switches to the next set parameter sub-menu. Control panel leaves the MENU mode if you wait for 10 seconds without pressing any button, and goes back to normal operation

6.14. Fan maximum speed setting (for FAN AUTO mode only)



You can set the maximum speed of the fan if you choose "fan operation mode" as auto as described in the previous page. Control panel allows you to set the maximum speed in fan modulation mode. If you feel the air is too much for your chimney installation and fuel to be loaded, then you may decrease the maximum speed of fan. In this case, fan will be operated between minimum speed and the maximum new speed you set. This feature will help the boiler save on fuel consumption.



To re-set the maximum speed of fan:

1. Press MENU button twice
2. The icon which points the setting parameter will blink
3. You can increase or decrease the new maximum speed between 3 and 5 pressing the buttons on right or left side of the MENU button

If you press MENU button once again, thermostat setting will be over, and the menu switches to the next set parameter sub-menu. Control panel leaves the MENU mode if you wait for 10 seconds without pressing any button, and goes back to normal operation.

6.15. Auto fan switch-off feature



When power is turned on by ON/OFF button of control panel, fan will automatically start no matter what the boiler temperature is. Then, fan will be operated according to your adjustments, that is modulated by electronic board between a minimum speed and a maximum default or re-set speed by the user. Fan is automatically switched-off when desired boiler outlet temperature is reached.

If boiler outlet temperature falls below 40 °C, electronic board keeps on operating fan as long as a pre-set safety time is elapsed. If boiler temperature does not exceed 40 °C again during this safety time, then control

panel assumes that there is no fuel in combustion chamber, and fan will be switched off. After this safety time, if boiler outlet temperature is over 40 °C again for any reason, fan will be switched on again. However, we recommend that you should reset the control panel by pressing ON/OFF button ONCE in that case.

Default value for safety time is 45 minutes. But you can re-adjust this safety time between 5 minutes to 90 minutes by 5 minutes intervals. To re-adjust safety time:



1. Press MENU button three times
2. The icon which points the setting parameter will blink
3. You can increase or decrease the new over-run time between 5 and 90 minutes pressing the buttons on right or left side of the MENU button

NOTICE
<p>Pump will operate as long as boiler outlet temperature is above 40 C. Pump is always kept switched off when boiler temperature is below 40 C, in order to prevent condensation and save energy. Control panel does not allow re-set on pump start temperature.</p>

6.16. Night (sleep) mode adjustments

You can use night mode if you do not need to warm the radiators and if you will not stop the boiler permanently. Using this feature you can have a small fire bed in combustion chamber, and you do not have to start-up the boiler from the very beginning. In this mode, fan is switched ON and OFF in respect with a pre-set duration so that it will only operate to maintain a minimum flame in the combustion chamber. According to factory set values, when this mode is activated, fan operates 120 seconds, and stops for 20 minutes. You can re-set this time intervals within the MENU. To re-set ON and OFF time intervals:

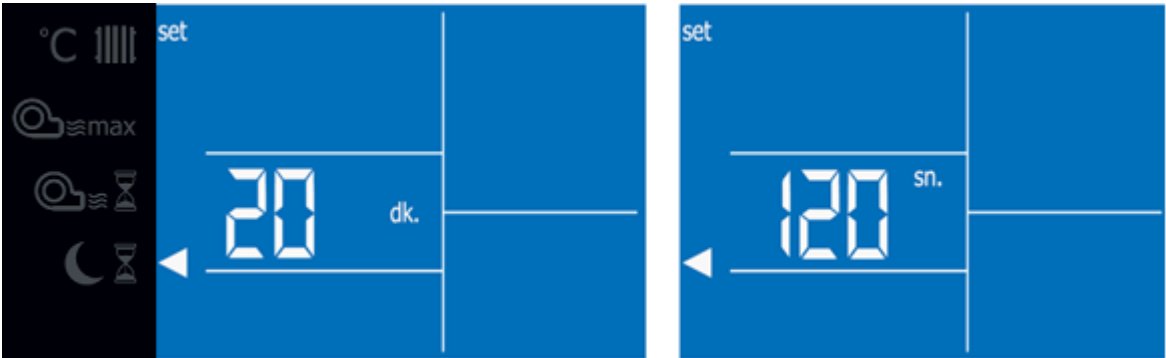

1. Press MENU button four times. The icon which points the setting parameter will blink
2. You can increase or decrease the OFF time between 10 and 40 minutes pressing the buttons on right or left side of the MENU button
3. Press MENU button again. The icon which points the setting parameter will blink
4. You can increase or decrease the ON time between 60 and 240 seconds pressing the buttons on right or left side of the MENU button

6.17. Slowdown the combustion

You can slowdown the combustion by:

1. Decreasing set value of boiler outlet temperature or switch control panel to ECO mode
2. Closing flue damper on smokehood to half closed or fully closed position (in case low fire bed)

You can combine the steps of 1 and 2, or if you do not want to warm your room you can set the control panel to NIGHT mode.

6.18. ECO mode

You can use ECO mode to shift boiler outlet temperature down to 50 C, if you do not need to much heat in your room instead of decreasing set temperature on the menu. If you want to leave ECO mode, and go back to standard operation just press ECO button once again.

6.19. NIGHT mode

If you want to activate NIGHT mode, just press NIGHT mode button on the control panel. When this mode is selected fan is switched to manual mode at the third speed level. As described above, we recommend you to activate this mode specially during night times when you do not need to heat up the radiators. If you want to leave NIGHT mode, and go back to standard operation just press NIGHT button once again.

6.20. Safety shut-offs

If boiler temperature reaches up to 100 °C for any reason, fan is shut-off, CH pump is kept in operation. Panel warns the user by high temperature icon on LCD an audible buzzer alarm. If boiler temperature falls below 95 °C again, buzzer alarms switches off, boiler switches back to its normal operation.

If boiler temperature reaches 110 °C, it means that there is a problem on control panel's PCB or sensors. In that case, an additional safety thermostat stops the boiler operation for an external safety. Sensing bulb of safety thermostat is attached on the boiler hot water outlet pipe, under the top panel of the boiler, and its reset button is outboard on top panel under a plastic cap. If boiler temperature is above 110 °C, fan is switched OFF, but pump is kept ON in order to protect the system against very high temperatures. E1 failure code appears on LCD. In this case, we recommend you to call for a service agent to check the control panel and its associated equipments. The safety thermostat is of manual reset type, and therefore it must be manually reset right after the problem is solved. Then the control panel is reset by pressing ON/OFF button once.

6.21. Turning off the panel

Control panel is turned off by pressing ON/OFF button. Never turn off the control panel when there is fire in combustion chamber.

NOTICE

Before opening the front door for fuel addition in combustion chamber, we recommend you to switch off the fan by pressing FAN CONTROL button. After closing the front door, switch on the fan again.

NOTICE

After each combustion period, before loading combustion chamber and ignition, the control panel must be reset by pressing ON/OFF button.

6.22. Room thermostat

You can install a room thermostat between the short-cut terminals of room thermostat contact outboard the control panel. If you do not use a room thermostat, leave this wire bridge as it is. When requested room temperature by room thermostat is reached:

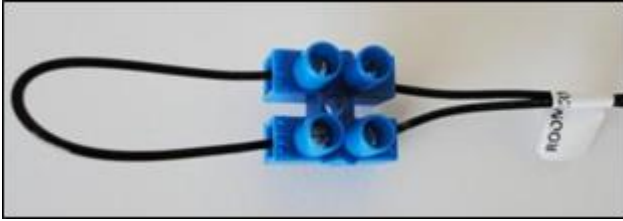

1. Fan and pump are switched off
2. In the meantime, if boiler temperature exceeds 75 C, pump will start and, be in operation until boiler temperature is below 70 C again

6.23. Failure codes and indicators

<p>code E1: High temperature. Bi-metal safety thermostat stopped the boiler code E2: NTC sensor fail</p> <p> High temperature warning</p> <p> No fuel warning</p>	
---	--

7 CLEANING AND MAINTENANCE

Boiler must be cleaned regularly and properly. Because ash settled down inside the ash pan and loading chamber together with condensates and tarr decrease the heat output of the boiler as well as reduce the boiler lifetime due to overheat and damage caused by isolation of heat transfer surfaces.

WARNING

When carrying out cleaning and periodic maintenance, always allow the boiler to cool down sufficiently after being shut down before opening the lower door. Always wear heat resistant gloves and protective clothing when handling ash.

7.1. Regular inspections

- Check the water level or pressure. The hydrometer must be marked after first filling of the boiler. So water level can be checked regularly. If the water level or pressure is under the level of static pressure or the system set-up, a water make-up is needed. The make-up water should be softened according the local regulations before feeding into the system to prevent corrosion inside the heating circuit and the boiler.
- Front doors of the boiler should be checked for properly closing. Fibre-glass ropes must be replaced if necessary.
- Check if there is flue gas leakage from the chimney connections of the boiler, and have it fixed if necessary.
- Check correct operation of thermo-regulator on top of the boiler. If needed you can slightly shift the setting of thermo-regulator for better combustion for your boiler capacity.
- Check the heat transfer surfaces of heat exchanger. The soot formation will change according to fuel type you use, and the combustion air amount. So if you feel that the outlet water temperature cannot reach the usual values with the same conditions, heating surfaces therefore should be cleaned.
- Check parts of ceramic nozzle. If you notice any crack contact with your reseller or installator.

7.2. Daily cleaning

In the combustion chamber of the boiler, special attention should be paid to thoroughly removing ash and slag from the grate slots and chamber walls. Combustion chamber can be cleaned partly through the charging door and partly through the lower door. Such cleaning should be performed before or after each firing of the boiler. The tools boiler is equipped with, are used for this purpose. Ash compartment located in the lower part of the boiler, must be regularly emptied of residues after cleaning of combustion chamber and grate (ash, dust, slag).

7.3. Weekly cleaning

Soot and tar deposits should be systematically removed from the walls of the combustion chamber, the ceramic nozzle in the lower part of the combustion chamber, the channels of the convection duct (vertical and horizontal), the smoke ducts and the flue.

Upper door allows access to the horizontal convection duct and smoke pipes. To clean upper part of the boiler, remove the fume gas retarders out of horizontal smoke pipes, and use the cleaning brush supplied with the boiler.

The vertical flue gas duct located at the back of the boiler above the ceramic nozzle should be cleaned with the special cleaning equipment supplied with the boiler. After cleaning, side cleaning covers must be re-installed tightly on the boiler ensuring sealing of the silicone gaskets

Clean the lower ceramic nozzle through side cleaning covers at the back and through the charging door. You can also remove the front ceramic nozzle part, loosening its locking sheet. This way, you can reach more heating surface of the boiler.

After all above operations dust, soot, tarr or slag accumulated at the bottom ash compartment should be removed.

Finally, you should clean the smokehood through the side cleaning covers on this part of boiler. And, re-install cleaning covers tightly and carefully.

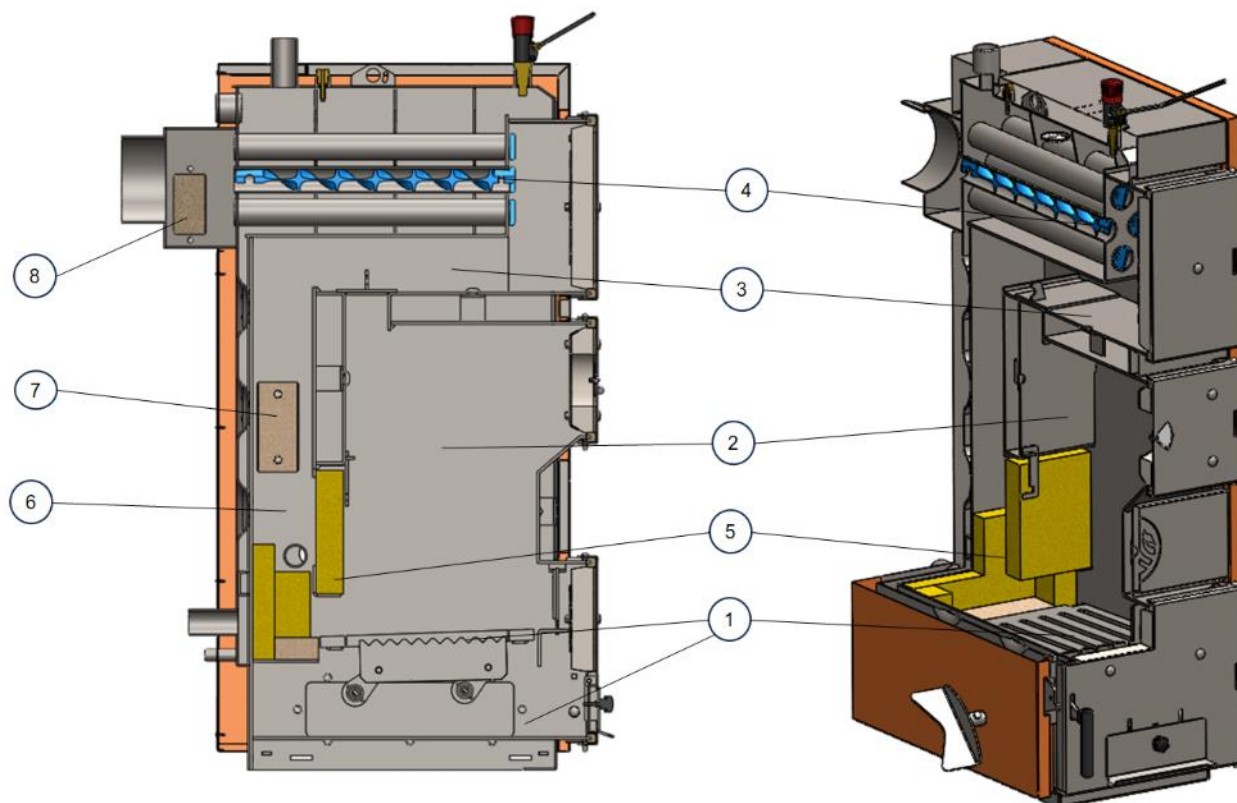

1	<i>Bottom grate and ash</i>	5	<i>Ceramic nozzle group (burner)</i>
2	<i>Combustion chamber</i>	6	<i>Vertical duct after nozzle</i>
3	<i>Horizontal duct</i>	7	<i>Side cleaning covers and</i>
4	<i>Smoke pipes with fume retarders</i>	8	<i>Smoke duct and smokehood</i>

7.4. Monthly cleaning

Flue duct between boiler smoke outlet and chimney should be cleaned regularly. After this operation, check the cleaning cover installed at lowest point of chimney.

7.5. Annual maintenance;

Before each heating season we would recommend you to call for the contracted service agent to check the boiler, heating system, electrical connections, and chimney conditions. Do not attempt to carry any maintenance work without getting help from qualified people.

NOTICE

During normal operation of boiler, if you sense smoke leak from fornt doors (fibre ropes), side and smokehood cleaning covers, stop the boiler immediately, and ask for assistance from your service agent / installer. Never attempt to replace or repair those parts of boiler by yourself

8 TROUBLESHOOTING

Problem	Possible causes	Remedy
Low thermal efficiency of the device	<p>Exhaust channels polluted or blocked by soot and residues</p> <p>No or insufficient fresh air supply to boiler</p> <p>Burning inappropriate fuels</p> <p>Boiler power selected lower than the total heat loss of the building.</p> <p>Wrong installation of heating circuit particularly for open vented systems</p> <p>Insufficient chimney draft</p>	<p>Clean boiler heating surfaces and ducts, check smokehood and flue channels</p> <p>Check ventilation of the boiler room</p> <p>For negative pressure rooms, you may need to install forced air ventilation</p> <p>Check parameters requested for the fuel</p> <p>Boiler needs to be replaced</p> <p>A heating engineer should check the installation</p> <p>See next section</p> <p>If chimney conditions can not be improved, you can add fan and electronics to improve the combustion</p>
Smoke leak from the boiler	<p>Insufficient chimney draft</p> <p>Insufficient height of the chimney</p> <p>Exhaust channels polluted or blocked by soot and residues</p> <p>Improper connection of the boiler with the chimney</p> <p>Very low atmospheric pressure</p> <p>Sealants on boiler doors or cleaning covers damaged</p>	<p>check the chimney and its parameters (see the diagram of compliance of the height and cross-section of the chimney with respect to the boiler power), check whether the chimney does not end below the highest roof ridge</p> <p>Raise the chimney to a height of not less than 1.5 m above the ridge</p> <p>Clean boiler heating surfaces and ducts, check smokehood and flue channels</p> <p>Check and correct it</p> <p>Use a fan to increase the chimney draft</p> <p>Replace the damaged parts</p>
Sudden increase in temperature and pressure in the boiler	<p>Closing the valves in the installation</p> <p>Expansion vessel freezing</p>	<p>Open the valves</p> <p>Insulate the expansion vessel</p>

Water leak from the boiler	<p>Water leak continues when there is no fire, and the temperature is low</p> <p>Water leak observed during fire start and before boiler reaches maximum set value</p>	<p>Call the service agent</p> <p>This is condensate water and it is normal that water may leak from the front door sealants. To minimize this issue, use dry woodlogs and follow firing instructions carefully</p>
Knocking noise from the boiler when it is becoming hot	There must be a filling or topping-up mistake, and there is air stuck inside the boiler	<p>Heating the boiler, i.e. maintaining the temperature above 70° C for a period of time until air bubbles are completely removed from the boiler</p> <p>Venting the central heating system using air vents on the radiators</p>
Too much fuel consumption	<p>Low fuel quality or high humidity</p> <p>Wrong placement of wood logs</p> <p>Not getting good flame inside the fuel chamber</p> <p>Exhaust fan speed is too much for existing installation</p>	<p>Improve the quality of wood, dry them in a ventilated area</p> <p>Check firing instructions</p> <p>Check firing instructions</p> <p>Set maximum exhaust fan speed to level 4 or 3 from the MENU</p> <p>Add / or change setting of draught limiter</p>

START-UP / COMMISSIONING FORM

1/2

END-USER INFORMATION

NAME / SURNAME	:	_____
ADDRESS	:	_____
CITY / PROVINCE	:	_____
COUNTRY	:	_____
E-MAIL / GSM	:	_____
SIGNATURE	:	_____

PRODUCT INFORMATION

PRODUCT MODEL	:	_____
EXTRAS 1	:	_____
EXTRAS 2	:	_____
INVOICE DATE and NUMBER	:	_____
SERIAL NUMBER	:	_____

COMMISSIONING OF THE DEVICE

DATE OF COMMISSIONING	:	_____
AUTHORIZED COMPANY for COMMISSIONING	:	_____
ADDRESS	:	_____
E-MAIL / GSM	:	_____
SERVISER NAME / SURNAME	:	_____
SERVISER STAMP and SIGNATURE	:	_____

- Warranty period is 2 (two) years, and starts with signing of this document
- One copy of this document shall be handed to end-user
- General checks on next page should be completed for future reference

START-UP / COMMISSIONING FORM

2/2

General Checks	Check	Comments
Wall plug voltage measurement	_____ V (AC)	
There is no damage because of transportation		
Chimney is clean, functioning well and meets the requirements defined in manuals		
Outputs are tested before start-up and working correctly		
Plumbing plant installation is made according to manuals, and necessary sensors are installed		
Optimization for auger / chimney calibration (if needed) is made		
Purchased optional elements are installed correctly, and tested		

End-User Notification	Check	Comments
User is informed about boiler/stove cleaning and service cycles		
User is informed about errors and how to act when they are shown		
User is informed about combustion power selection and setting necessary thermostats		
User is informed about boiler/stove functioning, operating, fuel quality and warranty conditions		

REMARKS / DIFFERENCES