



Installation and User Manual



HYDR A

Dear Customer,

Thank you for having chosen our product.

To allow for optimal operation and for you to enjoy the warmth and sense of wellbeing that the fire can convey in your home, we advise you to read this manual carefully before starting up the product for the first time.

CARE OF THE MANUAL AND HOW TO CONSULT IT

Take care of this manual and keep it in an easily accessible place.

Should the manual be misplaced or ruined, request a copy from your retailer or directly from the authorised Technical Assistance Department.

1 INTRODUCTION

HYDRA is a welded steel hydro-pellet stove with all hydraulic and safety accessories packed inside the cabinet. Main features and advantages of HYDRA are as follows:

Automatic ignition

PID control, output regulation

High heat resistant ceramic sightglass with auto cleaning system

Packed with all accessories such as;

- Circulation pump with frequency modulation
- 7 lt expansion tank
- Safety valve
- Automatic air relief valve
- Water pressure switch for low pressure
- Air pressure switch

Safety against back burning

Exhaust fan speed modulation

Burning pot made of special stainless steel

Manually activated cleaning system in smoke pipes

Auto switch-off when there is no fuel

HYDRA is delivered in one single wooden package with all external cabinets assembled, no additional assembly is required

2 WARRANTY CONDITIONS

THE MANUFACTURER guarantees the product, with the exception of elements subject to normal wear (listed below), for a period of 2 (two) years;

- Starting from date of start-up, which is proven by a commissioning document that contains the name of the seller and the date when the sale / first start-up took place
- If there is no service/commissioning report, standard guarantee period starts with the date when the sale took place.

The term 'warranty' refers to the (free-of-charge) replacement or repairs of parts acknowledged to be faulty due to manufacturing defects.

Furthermore, in order for the guarantee to be valid, the product must be installed and calibrated by qualified personnel. Installations that do not meet the current standards, improper use and lack of maintenance as expected by the manufacturer, void the product warranty. The warranty is valid on the condition that the instructions and warnings contained in this manual are observed, and therefore the product is used correctly.

The replacement of the entire system or the repair of one of its components does not extend the warranty period, and the original expiry date remains unchanged.

EXCLUSIONS FROM WARRANTY

Parts subject to normal wear such as gaskets, ceramic glass, cast iron grilles, vermiculite boards, fire bricks, fire stone burners, handles and electric cables, knobs, all parts which can be removed from the firebox, are excluded from the warranty

Any part that may be faulty as a result of negligence or careless use, incorrect maintenance or installation that does not comply with the manufacturer's instructions (see the relative chapters in user manuals of each product).

The warranty will be rendered null and void in the event of damage caused by tampering, atmospheric agents, natural disasters, vandalism, electrical discharges, fire, faults/defects in the electric and/or hydraulic system, and maintenance not being performed at all or as indicated by the manufacturer instructions

Non-regular electrical supplies, and electrical power cuts off too often, can cause severe damage on control system, sensors and actuators of the products carrying those components. We recommend installing 230 V 50 Hz AC voltage regulator for those products. Also installing a UPS for pumps can protect system from electrical cut-offs causing over heating of water.

The warranty does not cover malfunctions and/or damage to the appliance that arise due to the following causes:

- Damage caused during internal transportation and/or handling
- All parts that develop faults due to negligence or improper use, incorrect maintenance, installation that does not comply with the manufacturer's instructions (always refer to the installation manual provided with the product)
- Improper overheating of the equipment, use of fuels not conforming to the types and quantities indicated in the instructions provided
- Further damage caused by incorrect user interventions in an attempt to fix the initial fault
- Worsening of the damage caused by the user continuing to operate the appliance even after the fault has been noticed.
- In case of a boiler/hydro stove, any corrosion, incrustations or breakages caused by water flow, condensation, lack of water in the system, mud or limescale deposits
- Inefficiency of chimneys, flues or parts of the system affecting the appliance.
- Failure to have the annual product maintenance performed by an authorised technician or qualified personnel will result in the loss of the warranty.
- Save for the legal or regulatory limits, the warranty does not cover the containment of atmospheric and acoustic pollution.

THE MANUFACTURER declines all liability for any damage which may be caused, directly or indirectly, to persons, animals or objects as a consequence of non compliance with any provision specified in the manual, especially warnings regarding installation, use and maintenance of the appliance.

SPARE PARTS

Only use original spare parts. The retailer or service centre can provide all necessary information regarding spare parts. We do not recommend waiting for the parts to get worn out before having them replaced. It is important to perform regular maintenance.

The Manufacturer declines all liability if the product and any other accessory is used improperly or modified without authorisation. All parts must be replaced with original spare parts. Warranty cover is valid if the product is installed and tested by a qualified installer, according to the detailed instructions provided in the instruction manual supplied with the product. The term 'warranty' refers to the (free-of-charge) replacement or repairs of parts acknowledged to be faulty due to manufacturing defects.

3 SAFETY WARNINGS

- Installation, electrical connection, functional verification and maintenance must only be performed by qualified or authorised personnel. Install the product in accordance with all the local and national laws and standards applicable in the relative place, region or country.
- Only use fuel recommended in this manual. Do not put any fuel other than wood pellets in the hopper. Keep cover of the fuel hopper always closed.
- Do not place laundry on the product to dry. Any clothes or similar objects including the fuel must be kept at a safe distance from the product.
- Any type of tampering or unauthorised replacement with non-original spare parts could be hazardous for the operator's safety and relieve the producer/re-seller from any civil and criminal liability.
- Most of the surfaces of the product are very hot (door, handle, glass, smoke outlet pipes, etc.). Avoid contact with these parts unless adequate protective clothing is worn or appropriate means are used, such as heat protective gloves or cold handle type operating systems. When opening the front door, always use the unique apparatus attached at back side of the product. It is forbidden to operate the product with the door open or the glass broken.
- **THE PRODUCT MUST BE POWERED BY A SYSTEM THAT IS EQUIPPED WITH AN EFFECTIVE EARTH SYSTEM.**
- Switch the product off in the event of a fault or malfunctioning.
- Accumulated unburned pellets in the burner (fire pot) after each "failed start-up" must be removed before starting up again.
- Do not wash the product with water. The water could get inside the unit and damage the electrical insulation and cause electric shocks.
- **INSTALL THE PRODUCT IN ROOMS THAT ARE ADEQUATELY PROTECTED AGAINST FIRE AND EQUIPPED WITH ALL THE UTILITIES SUCH AS SUPPLIES (AIR AND ELECTRICITY) AND SMOKE OUTLETS.**
- If a fire breaks out inside the chimney, switch the appliance off, disconnect it from the mains and do not open the door. Then contact the competent authorities.
- If the ignition system is faulty, do not force ignition with flammable materials.
- Special maintenance must only be performed by authorised and qualified personnel.

DANGER – Risk of electric shock

- Switch off the system before performing work on the boiler.
- **THIS APPLIANCE MUST BE EARTHED !**

NOTICE – First operation

- It is quite normal to smell water vapour contained in the special coating of combustion unit of the product. This smell will go out through chimney after a few hours of first operation, and it should not be considered as a product defect.

4 MAIN PARTS AND SPECIFICATIONS

For end users:

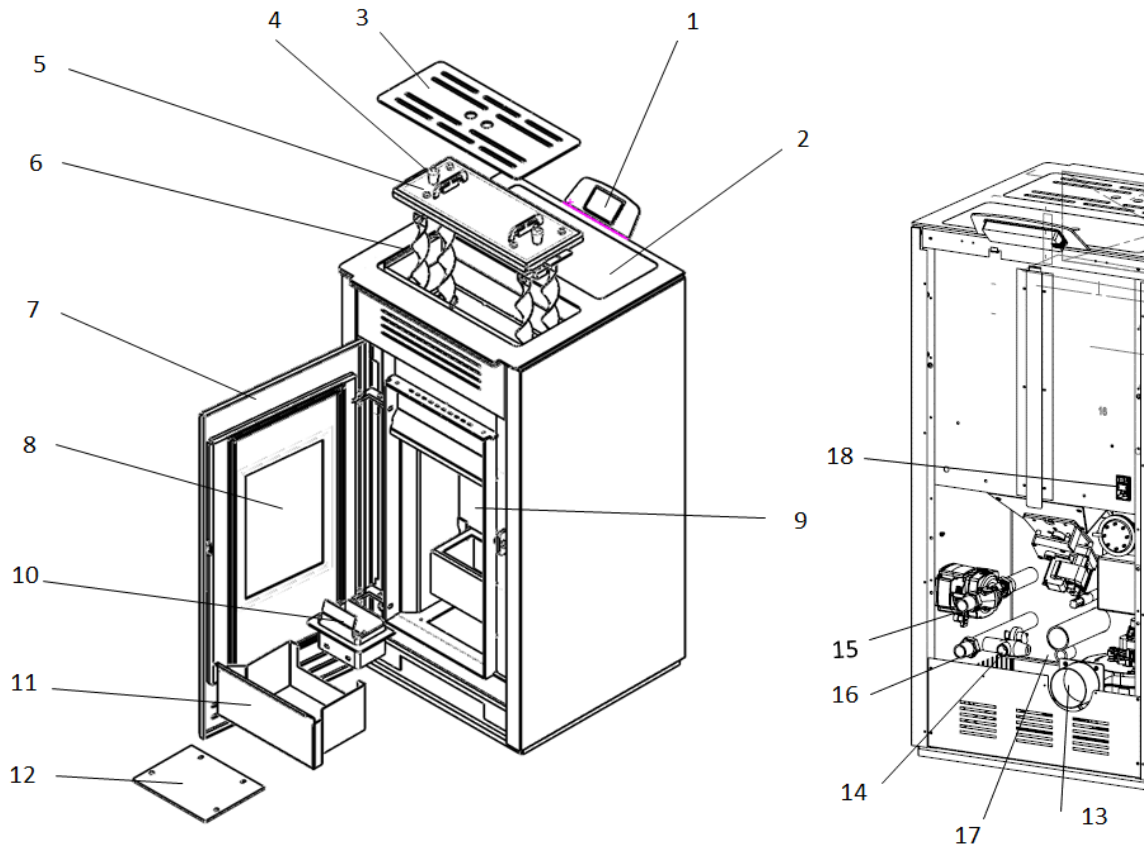

1	User interface and command display	10	Burning pot
2	Fuel loading cover	11	Ash tray
3	Cleaning cover	12	Smoke-hood cleaning cover
4	Smoke pipes cleaning knobs	13	Flue outlet
5	Combustion unit upper insulation panel	14	Safet valve outlet
6	Smoke pipes cleaning springs/turbulators	15	Hot water outlet
7	Fron door	16	Cold water inlet
8	Ceramic glass / inspection window	17	Filling - draining
9	Protection panels in combustion unit	18	Main switch

For installers / service staff:

19	<i>Air discharge valve</i>	26	<i>Cold water inlet pipe</i>
20	<i>Sensor pocket (boiler thermostat)</i>	27	<i>Hot water outlet pipe</i>
21	<i>Sensor pocket (safety limiter)</i>	28	<i>Exhaust fan</i>
22	<i>Safety limiter</i>	29	<i>Combustion air entrance</i>
23	<i>Air pressure switch</i>	30	<i>Ignitor</i>
24	<i>Expansion tank</i>	31	<i>Pellet feeding motor</i>
25	<i>Circulation pump</i>	32	<i>Water pressure switch</i>

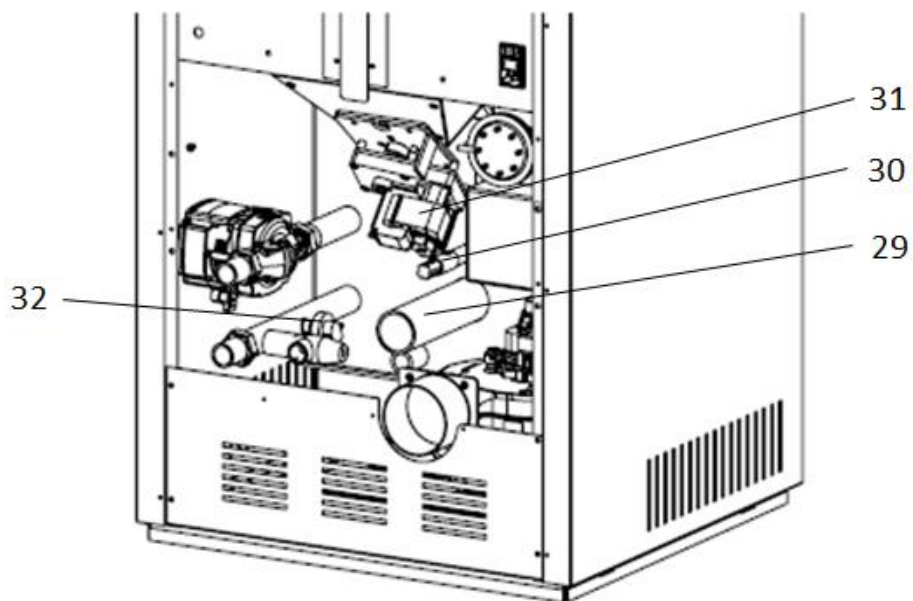
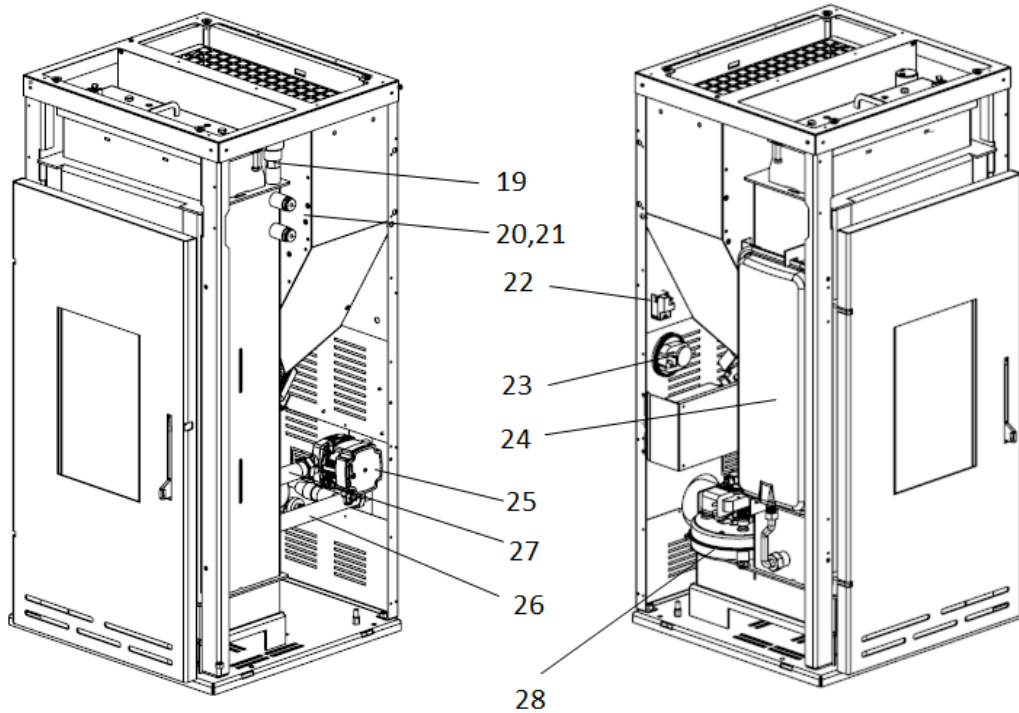

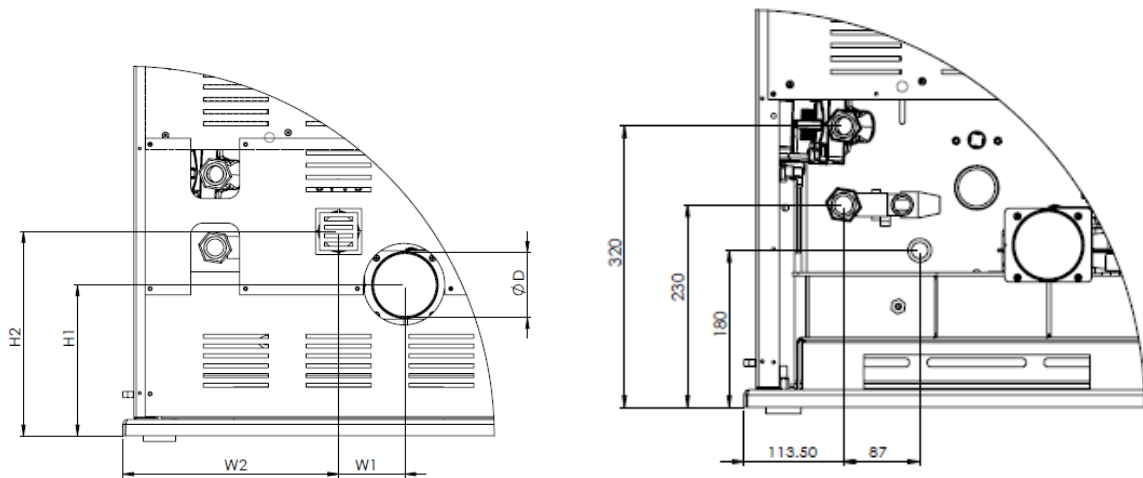

Model		HYDRA 12	HYDRA 16	HYDRA 24
Thermal power (min/max)	kW	5,9 / 11,8	6,4 / 15,7	10,0 / 24,7
Thermal power of fluid (water) (min/max)	kW	5,1 / 9,9	4,8 / 13,3	7,4 / 21,3
Hourly fuel consumption (min/max)	kg/h	1,38 / 2,82	1,53 / 3,78	2,38 / 5,95
Efficiency (min/max)	%	93,8 / 91,8	92,1 / 90,9	92,1 / 90,8
CO content (with 13% O2) min/max	%	0,0065 / 0,0075	0,013 / 0,0068	0,01 / 0,01
Flue temperature (min/max)	°C	87 / 120	98 / 138	97 / 143
Minimum draught	Pa	12		18
Maximum power rating	W	400		
Power rating at work	W	160		
Supply voltage and frequency	V/Hz	230/50		
Fuel tank capacity	kg	27	32	36
Expansion tank capacity	lt	7		
Maximum working pressure	bar	3		
Flow / Return (F / R)	R	3/4"		
Filling / drain	R	1/2"		
Safety valve (SV)	R	3/4"		
External dimensions				
Height	mm	1005	1075	1180
Width	mm	560		570
Depth	mm	540		590
W1	mm	80		112
W2	mm	265		285
H1	mm	185		220
H2	mm	250		265
D	mm	Ø 80		
Fresh air intake diameter	mm	Ø 50		

5 BEFORE INSTALLATION

5.1. Fuels

Pellets must comply with Class A1 or A2 according to EN 14961-2

Diameter (mm)	6 ± 1
Length (mm)	Max 40
Moisture (w)	$\leq 10\%$
Ash (w)	$\leq 1,5\%$
Net Calorific Value (kWh/kg)	≥ 4.4

To guarantee combustion without problems, pellets must be kept in a dry place. Poor quality pellets or others that do not comply with that specified previously compromises the operation of your product and can therefore render the warranty and product liability null and void.

5.2. Room selection / operating environment

The product must be installed in a suitable place for regularly operation and routine maintenance. The site must be:

- Compliant for proper operation.
- Equipped with an adequate smoke expulsion system. The product must be connected to a chimney or an internal/external vertical duct that complies with the regulations in force.
- The product must be positioned in such a way that the electrical socket is accessible.
- Equipped with ventilation intake from outside.
- Equipped with 230V 50 Hz power supply with an EC compliant earth system.
- Operating environment must ensure the following regulations unless any local regulation in force request different conditions
- The volume of the room where the product is installed should be no less than 15 m³. Air must enter through permanent openings made in the walls (near the product) that reach outwards with a minimum section of 100 cm² for Vega 12/16, and 150 cm² for Vega 24 without the protective grille. In the case of ducting, up to 3.5 linear meters, increase the cross-section by about 5%, whereas for longer ducts, increase it by 15%. These openings (air inlets) must be made in such a way that it is impossible for them to be obstructed in any way. The opening must be positioned in the lower part of an outer wall, preferably opposite to that in which the smoke evacuation duct is located.
- Air can also be drawn from adjacent rooms to the one that is to be ventilated, provided they have an external air inlet and are not used as a bedroom or bathroom or where there is a fire hazard, such as: garages, timber storerooms, warehouses of flammable materials, observing under all circumstances the the provisions of all the applicable standards in force.

- The adjacent room from which air is taken must not have a low pressure compared to the exterior due to a counter draught caused by the presence in that room of another appliance in use or of a suction device.

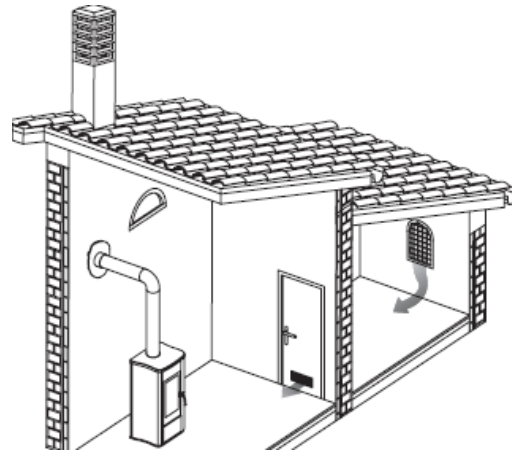

NOTICE

The product cannot be installed (except for sealed operation appliances with external ducted combustion air intake):

- in bedrooms or bathrooms;
- in rooms where there are liquid fuel appliances with continuous or intermittent operation that draw the combustion air from the room they are installed in;
- in rooms where there are B-type gas heating appliances, with or without domestic hot water production and interconnecting rooms;
- where another heating appliance is installed without an independent air flow.

It is recommended to install the stove detached from any walls and/or furniture, with a minimum clearance to allow effective aeration of the appliance and a good distribution of heat in the room. Observe the distances from flammable or heat-sensitive objects (sofas, furniture, wood panelling, etc..) as specified below. If particularly delicate objects are present, such as furniture, curtains or sofas, increase the stove clearance accordingly.

REFERENCES	FLAMMABLE OBJECTS	NON-FLAMMABLE
A	200 mm	100 mm
B	200 mm	100 mm

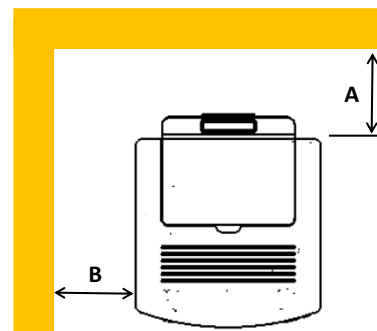

If the floor is made of combustible material, it is recommended to use protection made of non-combustible material (steel, glass...) that also protects the front from falling combusted material during cleaning operations.

The appliance must be installed on a floor with adequate load capacity. If the existing construction does not meet this requirement, one must take appropriate measures (for example a load distribution plate).

WARNING

- Heat-sensitive or flammable objects cannot be placed near the product. Keep such objects at a minimum distance of 80 cm from the outermost point of the product.
- Leave minimum 80 cm free space in front of the stove for loading, and cleaning of combustion unit.

5.3. Connection of the smoke exhaust duct

When making the hole for the passage of the smoke discharge pipe, one must take into account the possible presence of flammable materials. If the hole must be made through a wooden wall or thermolabile material, the INSTALLER MUST first of all use the appropriate wall fitting (minimum diameter 13 cm) and suitably insulate the pipe of the product that passes through it using adequate insulating materials (1.3 - 5 cm thick with minimum thermal conductivity 0.07 W/m°K). The same minimum distance must be applied if the pipe of the product must pass through vertical or horizontal sections near the thermolabile wall. It is recommended to use an insulated double-wall pipe in external sections in order to prevent condensation from forming. Note that the combustion chamber works in negative pressure.

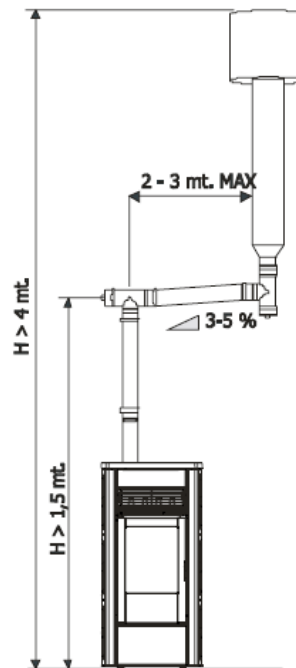

WARNING

- Always use pipes and fittings with appropriate seals that guarantee tightness.

NOTICE

The following conditions must be complied with when connecting the appliance to the chimney:

- The smoke duct must be at least category T200 (or higher if required by the smoke temperature of the appliance) and P1-type (airtight).
- All 90° angles (max. 3) in the smoke exhaust duct must be preferably fitted with the relative T-fittings with inspection hole.
- It is strictly forbidden to fit a mesh at the end of the exhaust pipe as it could cause the product to malfunction (due to clogging).
- It is forbidden to use counter-sloping pipes.
- The horizontal section of the smoke duct must not be longer than 2-3 m.
- It is also recommended not to exceed 6 metres in length with the pipe Ø 80 mm.
- The smoke duct must not cross rooms in which it is forbidden to install combustion appliances.

5.4. Connection to the chimney

The chimney must comply with the following requirements:

- Be waterproof and thermally insulated.
- Be made of suitable materials that resist mechanical stress over time, heat, the effects of the combustion products and any possible condensation.
- Have a vertical set-up with deviations from the axis of no more than 45° and free of bottlenecks.
- Must be suitable for the specific operating conditions of the product and have the CE marking (EN1856-1, EN1443).
- Must be adequately sized for the draught/smoke expulsion requirements that are necessary for the product to operate correctly (EN13384-1).

- The internal section is preferably circular.
 - In the case of a pre-existing product that has been used, it must be cleaned.
 - The chimney must not be shared with other appliances.
- 1) Windproof chimney pot, 2) Chimney 3) Inspection hole

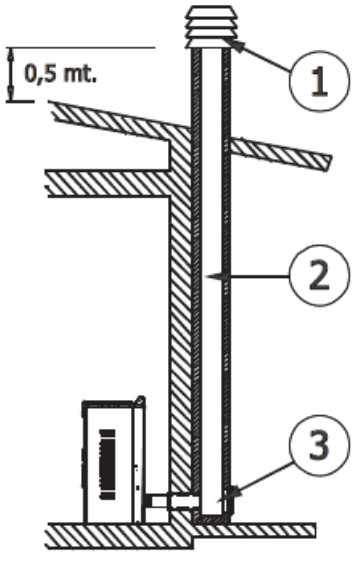
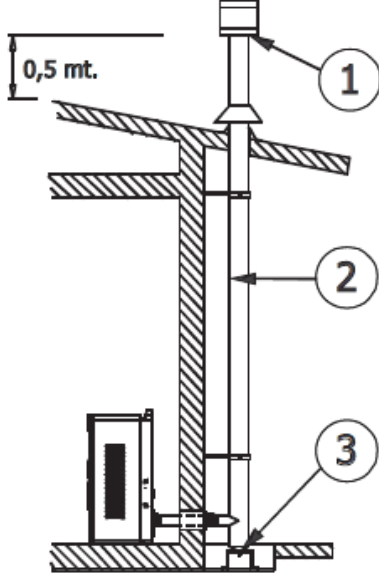
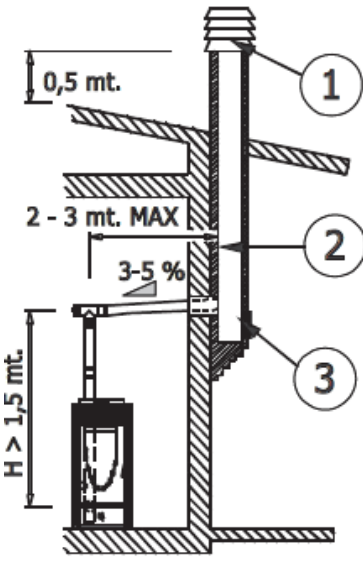
CONNECTION TO THE CHIMNEY	CONNECTION TO AN EXTERNAL DUCT WITH AN INSULATED OR DOUBLE-WALL PIPE	CONNECTION TO THE CHIMNEY
<p>The chimney's internal dimensions must not exceed 20x20 cm or 20 cm diameter; in the event of bigger sizes or bad chimney conditions (e.g. cracks, poor insulation, etc.), it is advisable to fit a stainless steel pipe of suitable diameter throughout the length of the chimney right to the top.</p>	<p>The minimum internal dimensions of the external duct must be 10x10 cm or 10 cm in diameter and must not exceed 20x20 cm or 20 cm in diameter. Only stainless steel insulated (double-wall) pipes must be used, which are smooth on the inside and fixed to the wall. Flexible stainless steel pipes must not be used.</p>	<p>The connection between the product and the chimney or the smoke duct must not have an inclination that is less than 3% in the horizontal sections, which must have a maximum overall length of 2/3 m. The vertical section between one T-fitting and another (angle) must not be less than 1.5 m.</p>
		

5.4. Chimney stack

The chimney stack is a device fitted on the top of the chimney that is designed to aid dispersion of the products of combustion in the atmosphere. Chimney stack must comply with the following requirements:

- it must have an internal section and shape the same as the flue (A);
- it must have a useful outlet section (B) of not less than twice that of the flue (A);
- the part of the chimney that emerges from the roof or remains in contact with the outside (e.g. in the case of a flat roof), must be covered with brick or tile elements and in any case well insulated;
- it must be built in such a way as to prevent the penetration of rain, snow and foreign matter into the flue and to ensure that in the event of winds from all directions and angle, discharge of the combustion products is assured (chimney stack with down-draught cowl).

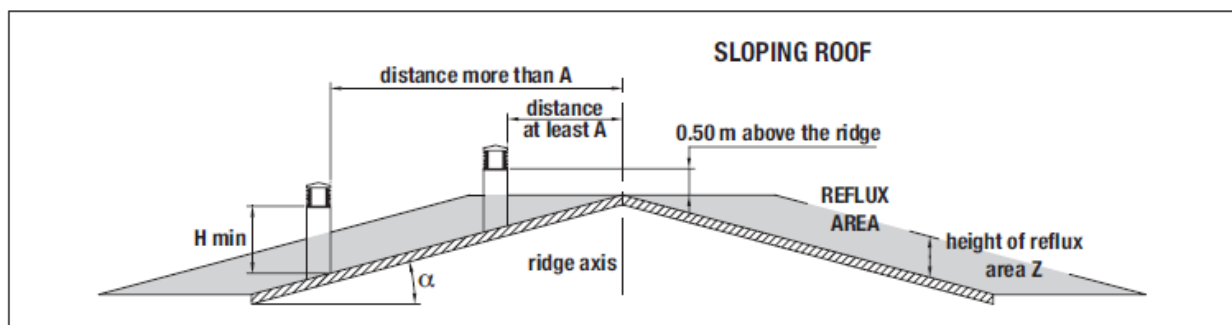
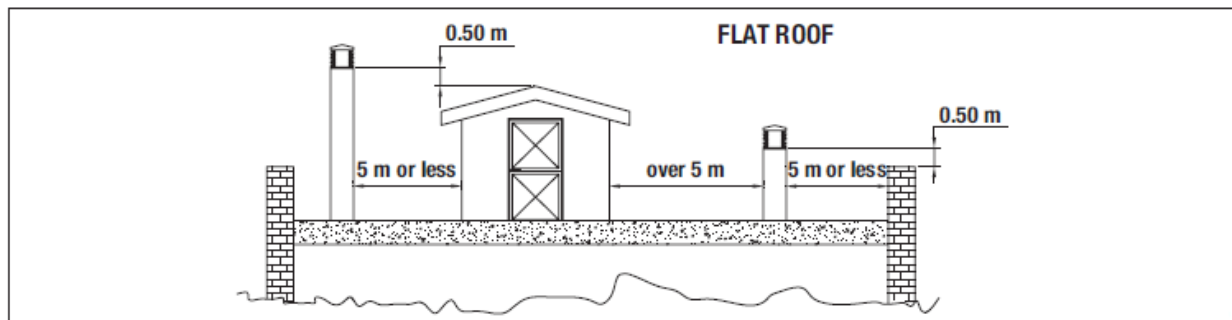
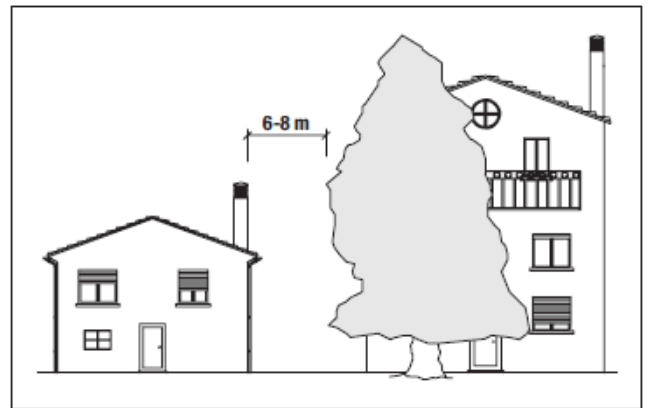
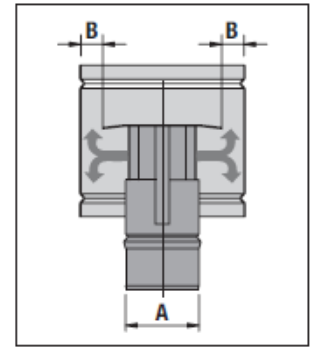
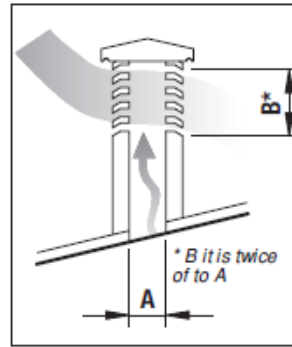

Pitch of the roof	Horizontal width of reflux area from ridge axis	Minimum height of outlet from roof	Height of reflux area
α	A	H	Z
15°	1.85 m	1.00 m	0.50 m
30°	1.50 m	1.30 m	0.80 m
45°	1.30 m	2.00 m	1.50 m
60°	1.20 m	2.60 m	2.10 m

6 INSTALLATION AND PLUMBING

6.1. Unpacking

The stove is supplied complete with all its electrical and mechanical components and factory-tested. Open the package and cut the strip that fastens the stove to the pallet.

If possible, unpack the stove near the chosen place of installation. Set the stove in the pre-selected place, making sure this complies with the requirements. The stove body or unit must always be kept in a vertical position when handled and moved by using carts only. Pay particular attention that its door and its glass are protected from knocks that might compromise their integrity. There are four rubber bases supplied with the stove. Screw them into nuts fitted bottom level of the stove, and balance the stove by adjusting those rubber bases up and down.

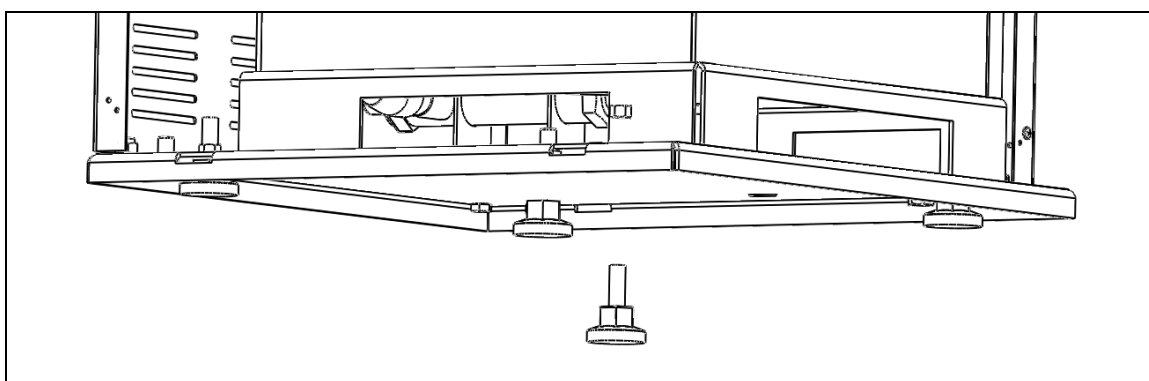

The materials that make up the packaging are neither toxic nor harmful, and so require no particular disposal measures. After removing the packaging make sure that the stove is complete and not damaged. If in doubt contact the dealer.

6.2. Hydraulic connections

This appliance has been designed to heat not only the immediate surrounding environment, but also water for a hot-water type heating system. When the appliance is operating regularly it produces hot water at a temperature that is necessarily below boiling point and a heating system must therefore be designed that is suited to the characteristics of the appliance.

The installer must connect the appliance to the water system as shown in following diagram. This set-up allows:

- an instant check of filling or operating pressure of the system (MANOMETER WITH SCALE 0 ÷ 6 BAR) (2)
- the stove to be moved slightly for maintenance or cleaning purposes, without disconnecting it from the water system (HOSES) (4)
- The original system filling water and any topping-up water must always be filtered (using synthetic or metal mesh filters with a filtration rating of no less than 50 microns) to prevent sludge from forming and triggering deposit induced corrosion (STRAINER/FILTER) (5)

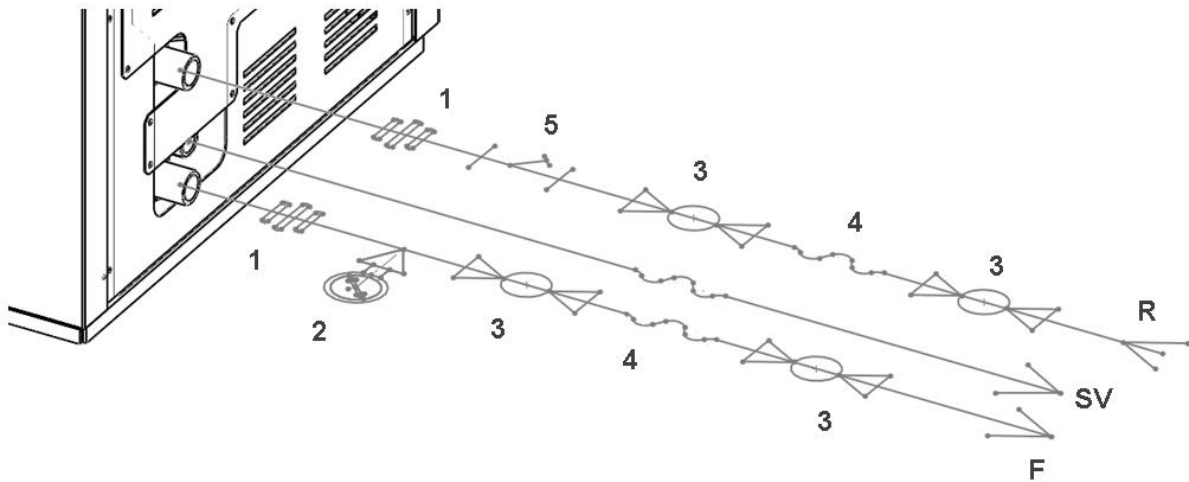

- the stove to be disconnected from the water system without having to empty either the stove boiler or the actual system (BALL VALVES) (3)
- the appliance to be disconnected quickly without subjecting the connecting pipes to stress (3-PIECE PIPE UNION) (1)

The safety valve must be connected using a hose without shut-off devices, which could obstruct the free flow of fluid under pressure. Check that any kinks in the hoses will not allow air locks or pockets to form or obstruct the free flow of water.

NOTICE

Before connecting the appliance, flush the heating system through to eliminate any residues (oil, swarf, drops of weld material, hemp, rust) inside the pipework, which could otherwise damage the appliance or cause malfunction. Insulate the connecting pipework adequately to prevent heat loss and the formation of condensation. Under no circumstances light the appliance unless the water circuit is completely filled with water.

The expansion tank installed inside the appliance is only sufficient to compensate the water in the appliance and up to a MAX. of 20 lt of water in the system; the part of the system corresponding to this quantity must be near the appliance and run relatively straight.

Installation of a suitably sized additional expansion tank is however recommended to compensate for the quantity of water present in the heating system. The correct size of the expansion tank must be calculated by a qualified heating plumber. As an example, the design calculations for an expansion tank are given below, taking into consideration the following:

- cold temperature of fluid 15°C
- maximum working temperature of fluid 90°C
- difference in level between additional expansion tank and relief valve (3 bar) equal to or less than 1.5 m
- pre-filling pressure of the expansion tank 2 bar.

The capacity of the closed expansion tank required by a heating system with such characteristics can be calculated with the following formula:

$$V_v = V_o \times 0.16$$

- V_v = volume of the expansion tank in l
- V_o = water content of the system in l

- 1 Three piece pipe union
- 2 Manometer
- 3 Ball valve
- 4 Hose
- 5 Strainer (filter)
- 6 Check valve

- 7 Expansion tank
- 8 Drain
- 9 Safety valve
- 10 Air relief valve
- 11 Radiator
- 12 Filling / draining

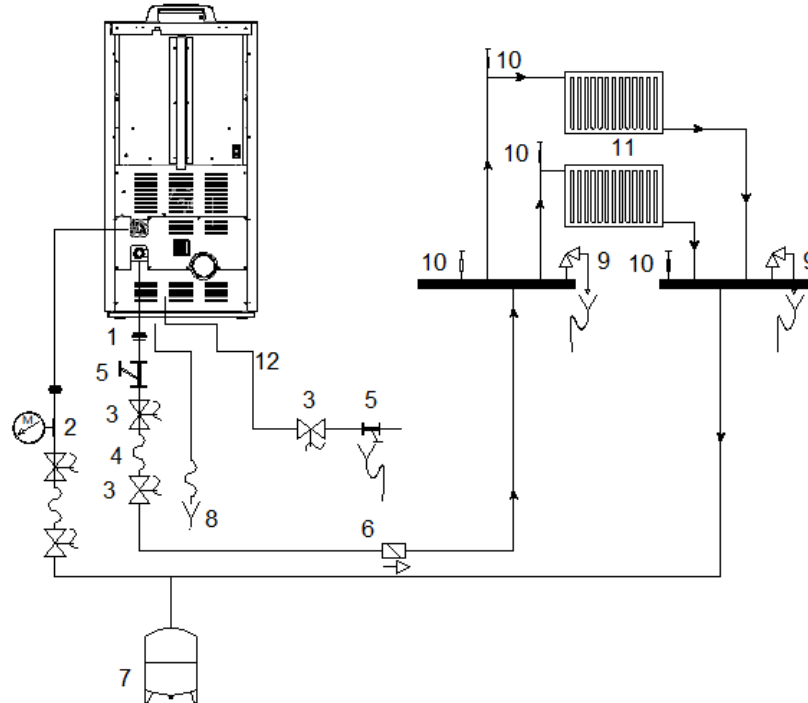

6.3. System filling

Fill the water heating system when the appliance is shut down. Under no circumstances light the appliance if the boiler is not full of water. Filling must be carried out slowly so that air bubbles can get out via the purposely placed outlets on the heating system. In closed circuit heating systems the loading pressure of the system when cold and the expansion tank preloading pressure must be the same.

WARNING

- Do not mix the heating water with antifreeze or anticorrosion substances in the wrong concentrations! It can damage the seals and cause the onset of noise during operation.
- Boiler has internal water mixing system which needs pressurised water circuit. Any filling and draining must be made through the filling/drain port. If inlet and outlet ports are used for filling, installer must ensure that all air inside the boiler is released.

To fill the system, the boiler is fitted with a tap, with a check valve, to load the heating system manually. During this operation, any air in the system is released via the air valve located in the upper part of the boiler.

- Open the radiator, and boiler air discharge valves;
- Gradually open the system filling tap making sure that any automatic air valves installed on the system work properly;
- Close the radiator air valves as soon as water starts to come out;
- On the system pressure gauge check that the pressure reaches a value of approximately 1 bar;

- Close the system loading tap and then bleed air again via the radiator air valves; and check tightness of all connections;
- After having started the boiler for the first time and heated up the system, stop the pumps and repeat the air bleeding operations;
- Let the system cool down and if needed take the water pressure back to 1 bar. The water pressure in the heating system - when the system is cold - must be no less than 1 bar; if under this value, act on the system filling tap. The operation must be carried out when the system is cold. The system pressure gauge enables to monitor the pressure in the circuit.
- Auto air discharge valve of the stove is reached after removing top and of right hand side panel:

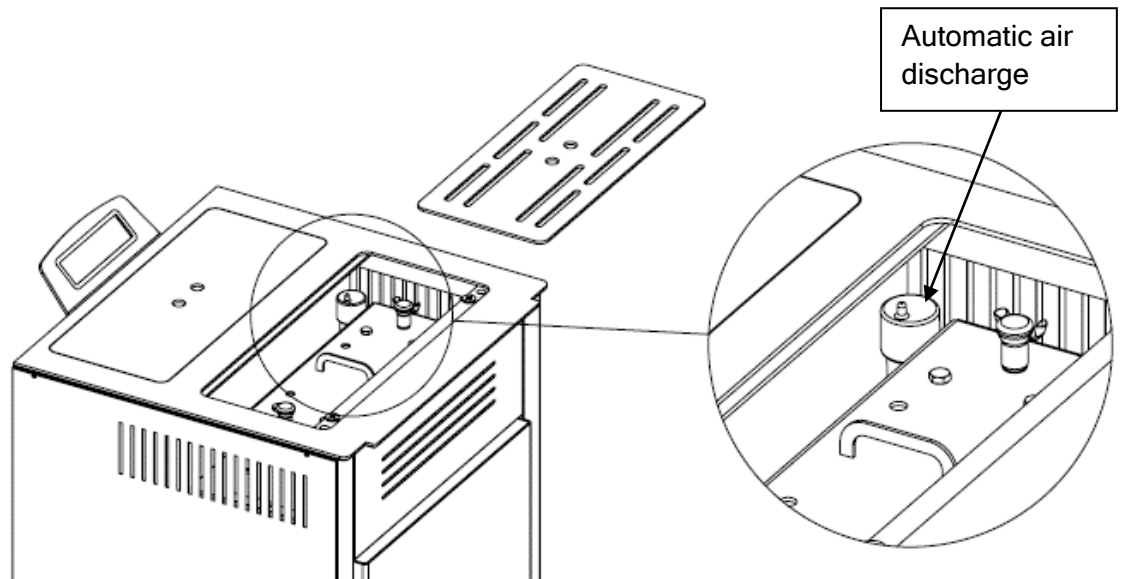

6.4. Electrical connection

Electrical safety of the system is ensured only when it is properly connected to an efficient earthing system made in compliance with the safety standards in force. Gas, water or heating systems pipes are not suitable as earth connections. Check if the electrical system is suitable for the maximum power absorbed by the heating system, ensuring in particular that the diameter of cables is appropriate for the power absorbed by the loads. The use of any component that is powered by electricity entails compliance with some basic rules such as:

- do not touch the appliance with wet and/or damp body parts and/or bare feet;
- do not pull the electric cables;
- do not leave the appliance exposed to weathering (rain, sun, etc.);
- do not allow the appliance to be used by children or inexperienced persons.

Installation of the boiler accessory electrical components requires electrical connection to a 230 V - 50 Hz mains.

NOTICE

- Electrical installation must be carried out by a qualified technician only.
- Before performing connections or any operation on the electrical parts, always disconnect the power supply and make sure it cannot be accidentally reconnected.
- Please note that the boiler electrical power line must be fitted with a bipolar switch with a contact gap greater than 3 mm, easy to access, in order to make any maintenance operations quick and safe.

- The power cable must be replaced by authorised technical personnel.
- If the supply cord is damaged, it must be replaced by a special cord or assembly available from the manufacturer or its service agent.

First connect the power cable to the stove and then to a wall socket. The main switch at the side must only be activated to switch the stove on; otherwise, it is advisable to keep it off.

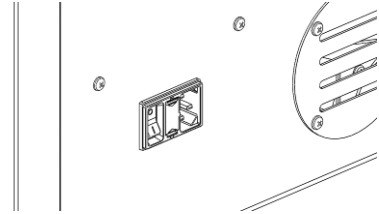

WARNING

- It is recommended to disconnect the power cable when the stove is not used.

6.5. External room thermostat

The external thermostat can be used to turn the combustion system on and off. In this case the controller ignores all internal temperature thresholds and is operating exclusively with the thermostat input. To configure this option; connect room thermostat wires into the ports of green connector on board as seen below

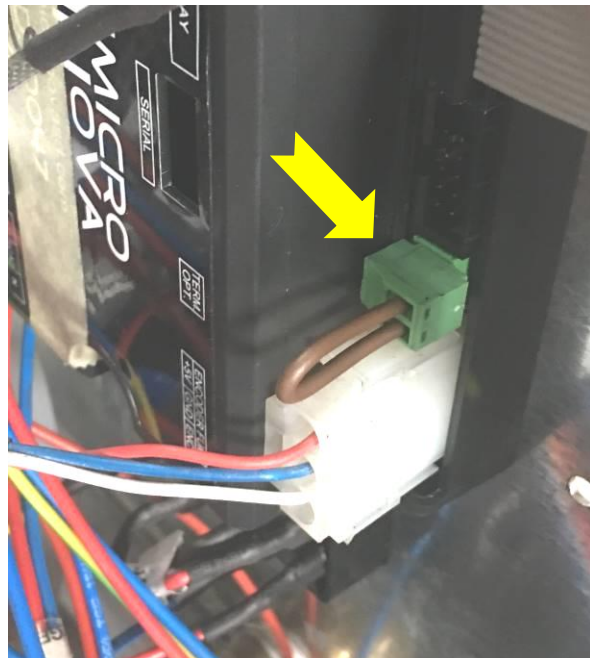

7 INITIAL START-UP

7.1. Before start-up

Check that the fire pot is positioned correctly and rests properly on the base. Fire pot ring fits into fire pot by its sides. Fire pot ring ensures all pellets will enter the fire pot, protects burning pellets from moving out from the pot

Once the power cable is connected in the rear part of the stove, turn the switch to position (I). To switch the stove on or off press ON/OFF button (4) on the control panel.

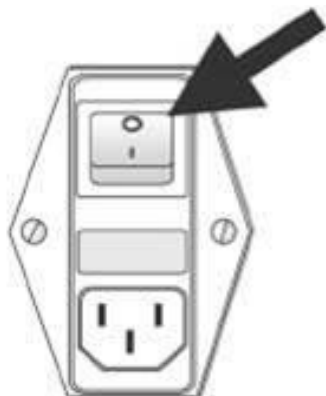

7.2. Loading the pellets

Fuel is loaded by lifting the cover on the upper part of the product. Slowly pour the pellets into the hopper. Be careful as the cover could become very hot. No other type of fuel other than pellets, in compliance with above-mentioned specifications, is to be inserted into the hopper.

WARNING

- Do not allow sawdust to accumulate on the bottom of the hopper.
- Do not leave leftover pellets on top of the stove - they could catch fire!

7.3. Opening and closing the door

To open the door, lift the hook, as shown in the figure"

Door hook is hanged at the back of the stove

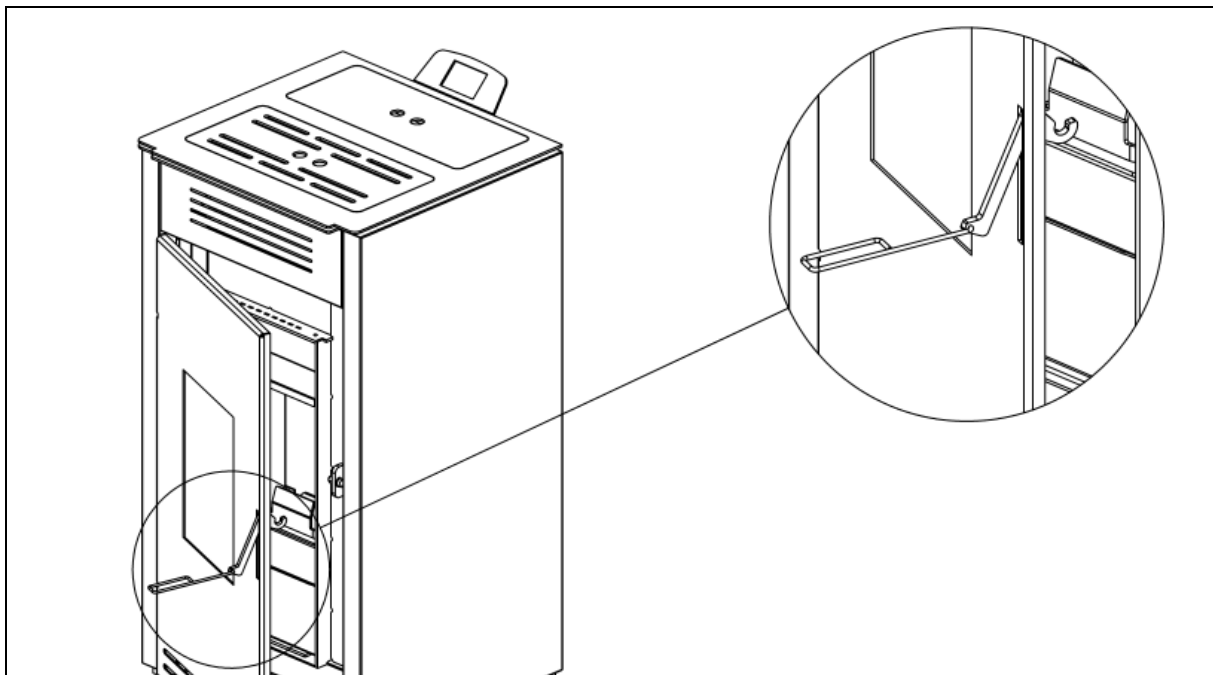
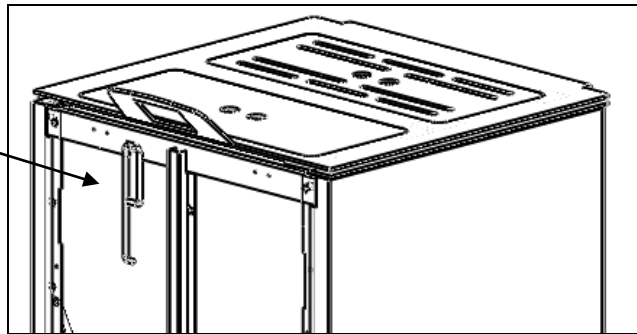

WARNING

- The door must be closed properly for the stove to work correctly.
- "Use suitable Personal Protective Equipment (e.g. gloves) to open the stove door.

NOTICE

- Stove is equipped with a water pressure switch that protects the boiler from operation without water inside. The minimum setting of pressure switch is 0,2 bars. That is why, your stove will not be in operation, unless water pressure inside the hydraulic circuit is above 0,2 bars.

8 OPERATION

8.1. User Interface

Through the console, you can communicate with the control board simply by pressing few buttons. The display and LED indicators inform the operator of the operating status of the heater. In the programming mode, various parameters, which can be modified by pressing the keys, are displayed. Following figure describes the standard use of the console:

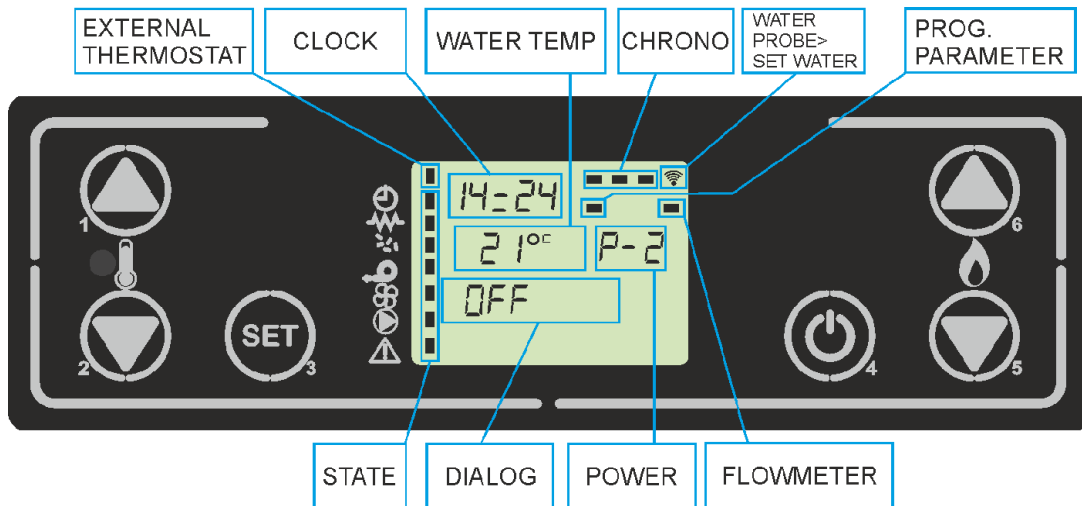
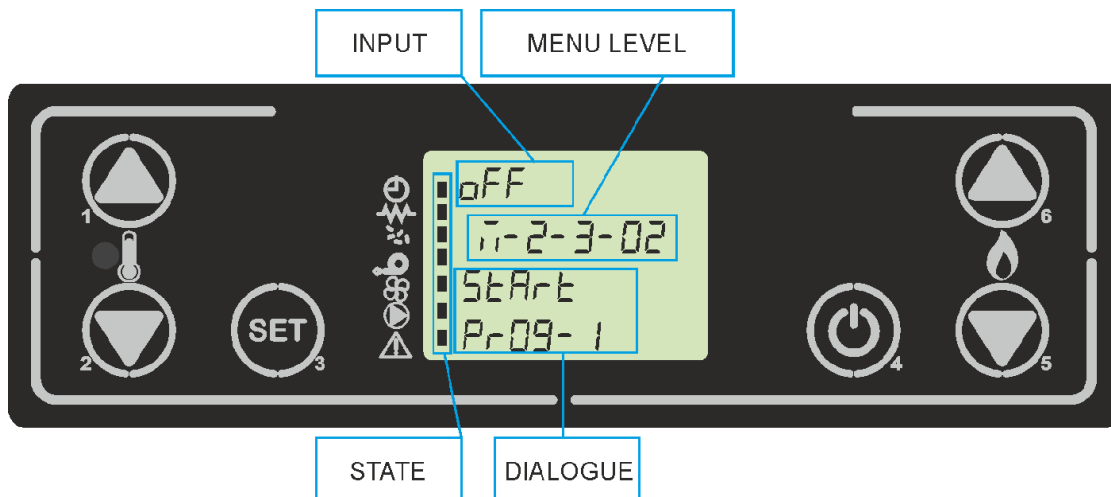

Figure on the right demonstrates the meanings of the status symbols on the left of the display. The activation of one of the symbols in the “status” area on the display indicates the activation of the corresponding device according to the list. Following figure indicates the layout of the messages in the programming or setting phase. Particularly:

- Programmable thermostat
- Ignitor
- Auger (pellet feeder)
- Exhaust fan
- Not available on this model**
- Circulator (pump)
- Alarm

1. The input section displays the chosen settings.
2. The menu level section displays the current menu level. See the chapter about the menus



Next figure shows the change of the water temperature in the WORKING \ MODULE state.

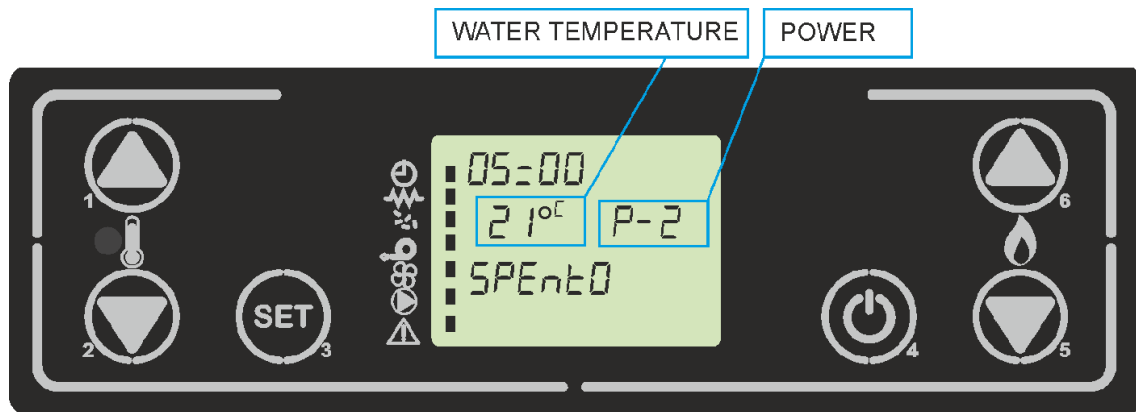

Button descriptions:

Button	Description	Mode	Action
1	Increase Temperature	PROGRAMMING	Adjusts/increases the value in the selected menu
		ON/OFF	Increases the set value of temperature water/room desired
2	Decrease Temperature	PROGRAMMING	Adjusts/decreases the value in the selected menu
		ON/OFF	Decreases the set value of temperature water/room desired
3	Menu		Accesses the menu
		Menu	Accesses the submenu level
		PROGRAMMING	Sets the value and moves to the next menu
4	ON/OFF Unlock	ON/OFF	Held for 2 seconds to switch the stove on when in off mode, or off when in on mode
		LOCK	Unlocks the stove and puts it into off mode
		MENU/PROGRAMMING	Brings you to the next menu level, any adjustments made will be saved
5	Decrease Power	ON/OFF	Adjusts the power produced by the stove
		MENU	Takes you to the next menu level
		PROGRAMMING	Takes you to the next submenu, any adjustments made will be saved
6	Increase Power	ON/OFF	Adjusts the speed of the air exchanger
		MENU	Takes you back to the previous menu level
		PROGRAMMING	Takes you to the previous submenu, any adjustments made will be saved

8.2. Operating Mode

8.2.1. Starting The Stove

To switch on the stove, press P4 for a few seconds. The ignition is signalled in the display with the word "Start" as shown in next figure. The ignitor and the exhaust fan (fumes extractor) light up in the status box. This phase lasts for a time preset at factory, within which the stove must light up. If the stove doesn't switch by the end of the expired time, it goes into alarm state with the corresponding message on the display.

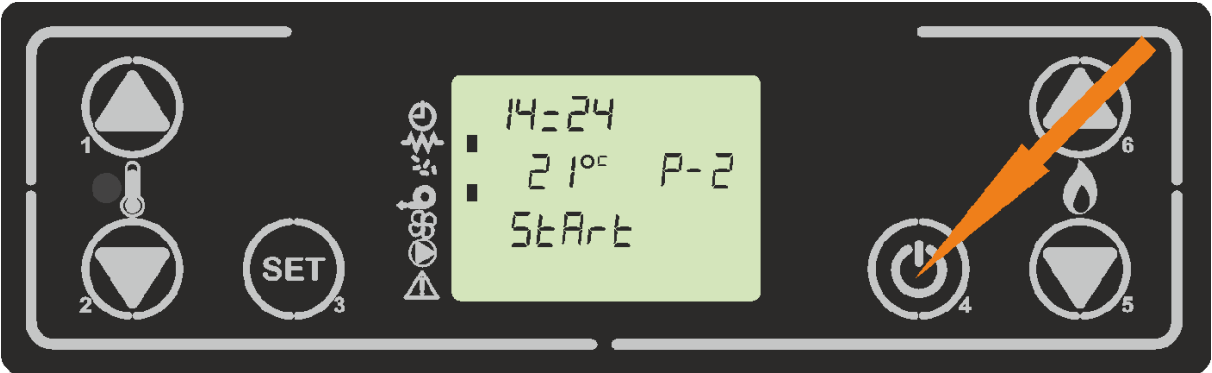

8.2.1.1. Preheating Wait

In this phase, ignitor is heated and goes to full power. The exhaust fan stays on and at the speed set for ignition at factory

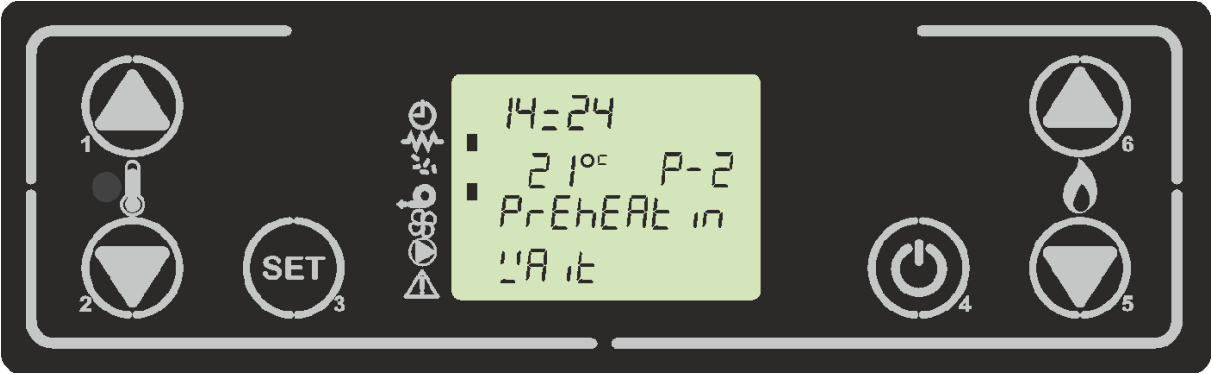

8.2.1.2. Load Pellet

In this phase, the pellet feeder works continuously to make a pellet pile in the fire pot for the first ignition

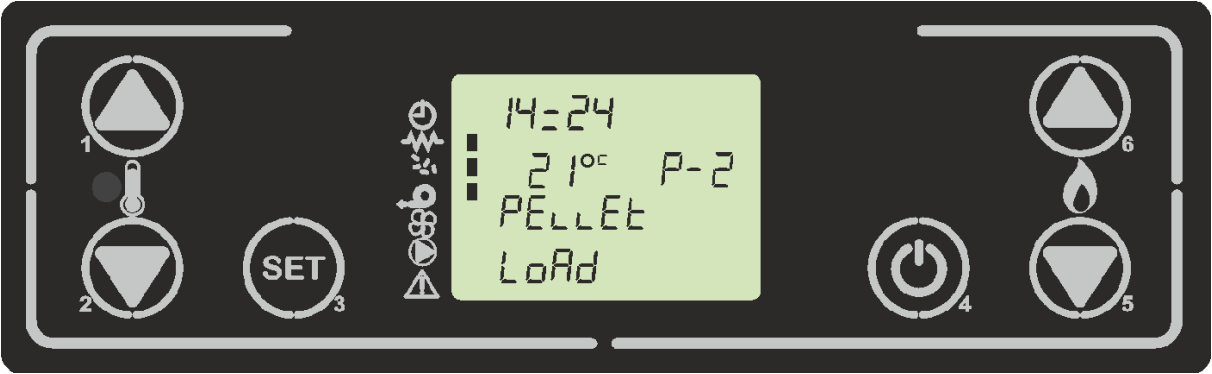

8.2.1.3. Waiting Fire

After charging the pellets, the auger switches off, and the pellets are expected to be ignited. If the flue temperature exceeds the threshold set at factory, the controller goes directly to the present fire phase

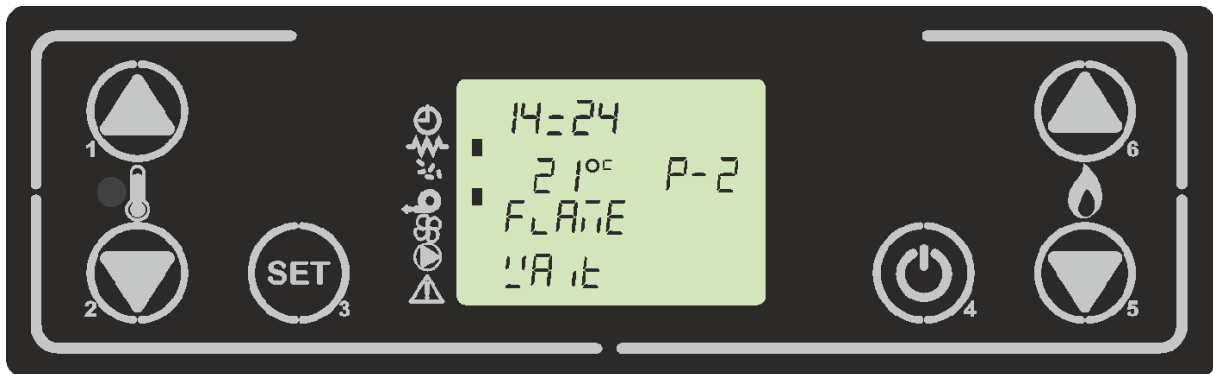

8.2.1.4. Load Pellet/Waiting Fire

Waiting for the phase of the flame, on display shows one of the following alternatives. It is expected that smoke temperature exceeds the threshold set at factory to go to the "fire present" phase.

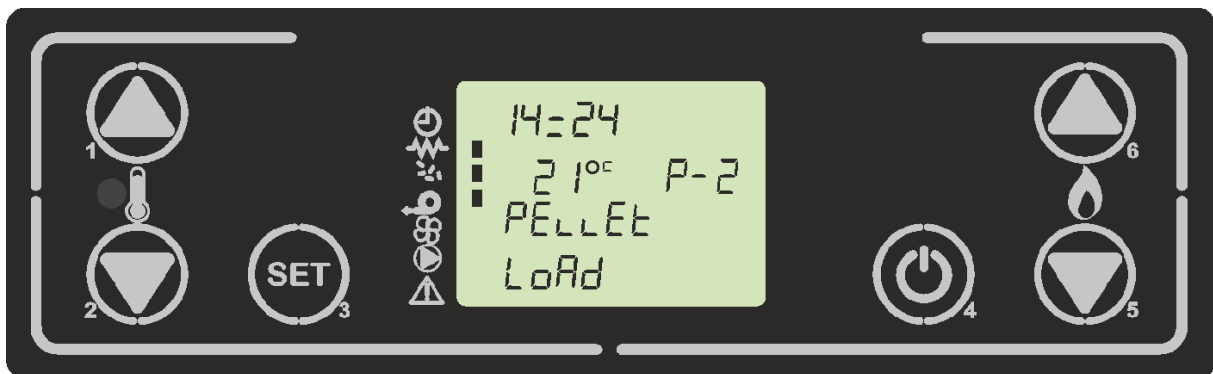

or

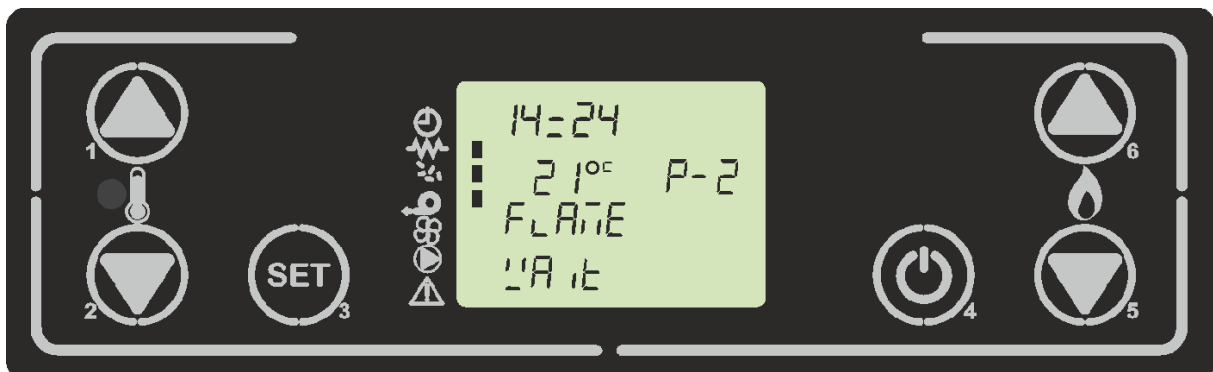

8.2.1.5. Fire Present

After the smoke temperature has reached and exceeded a pre-set value, the system goes into start-up mode and shows the following message on the display. In this phase exhaust

fan speed and pellet feeding rate is increased so as to build a stable and ongoing flame in the fire pot. During that phase, ignitor is switched off, as there is flame present in the pot.

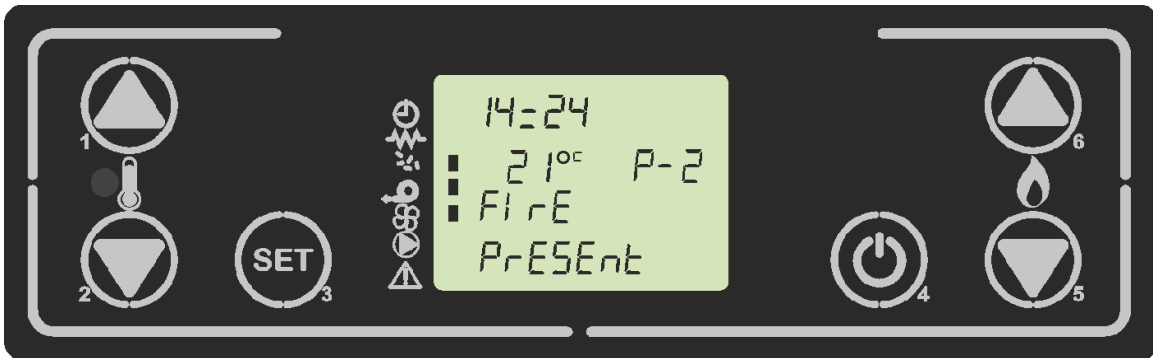

8.2.2. Working Mode

This is the working modality of the stove, the display shows the writing “Work”. In this modality, you can modify the available user’s sets, which we will describe in the following chapters, and the stove will work to satisfy them.

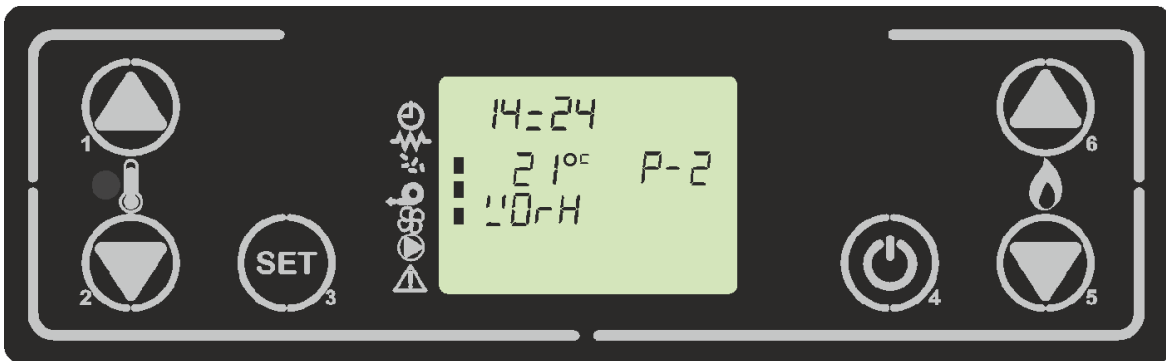

8.2.2.1. Adjusting Set Power of Stove

To adjust the power set of the stove, press P6, then to increase press key P6 or decrease P5. To exit, press P4 keys or wait 5 seconds. This set has 5 levels.

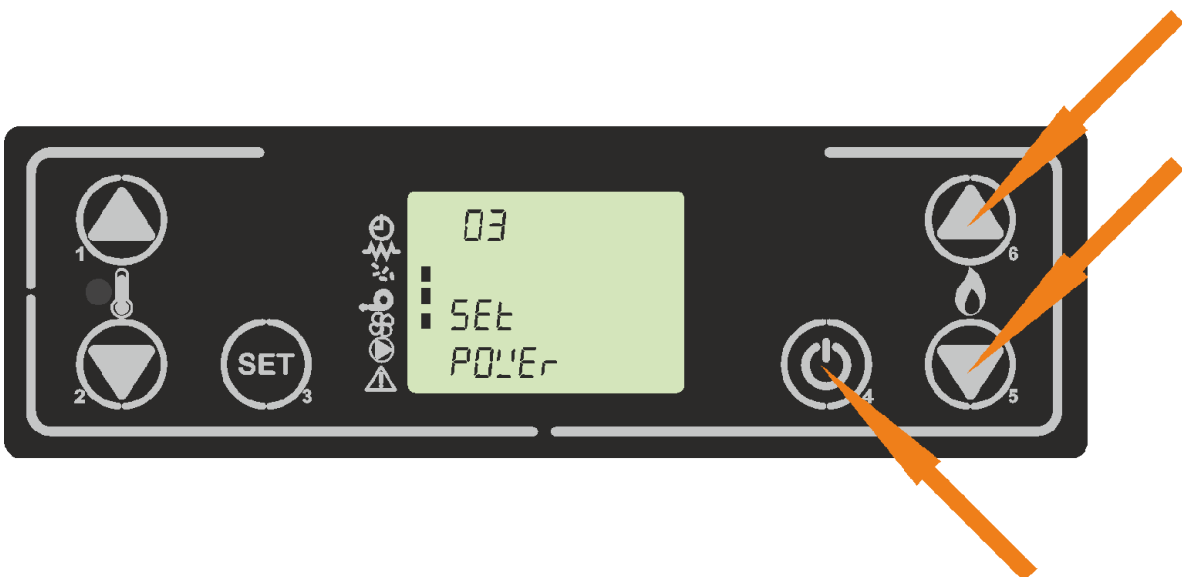

8.2.2.2. Menu Levels:

Level 1	Level 2	Level 3	Value
Menu 01 - Set Clock			
	01- Day week		M-T-W-T-F-S-S
	02- Time clock		0-23
	03- Minutes clock		0-59
	04- Day clock		1-31
	05- Mounth clock		1-12
	06- Year clock		00-99
Menu 02 - Set Chrono			
	M-2-1 - Chrono Enable		
		01- Chrono Enable	on/off
	M-2-2 - Program Day		
		01- Chrono Day	on/off
		02- Start 1 Day	OFF-0-23:50
		03- Stop 1 Day	OFF-0-23:50
		04- Start 2 Day	OFF-0-23:50
		05- Stop 2 Day	OFF-0-23:50
	M-2-3- Program week		
		01- Weekly Chrono	on/off
		02- Start Prog 1	OFF-0-23:50
		03- Stop Prog 1	OFF-0-23:50
		04- Monday Prog 1	on/off
		05- Tuesday Prog 1	on/off
		06- Wednesday Prog 1	on/off
		07- Thursday Prog 1	on/off
		08- Friday Prog 1	on/off
		09- Saturday Prog 1	on/off
		10- Sunday Prog 1	on/off
		11- Start Prog 2	OFF-0-23:50
		12- Stop Prog 2	OFF-0-23:50
		13- Monday Prog 2	on/off
		14- Tuesday Prog 2	on/off
		15- Wednesday Prog 2	on/off
		16- Thursday Prog 2	on/off
		17- Friday Prog 2	on/off
		18- Saturday Prog 2	on/off
		19- Sunday Prog 2	on/off
		20- Start Prog 3	OFF-0-23:50
		21- Stop Prog 3	OFF-0-23:50
		22- Monday Prog 3	on/off
		23- Tuesday Prog 3	on/off
		24- Wednesday Prog 3	on/off
		25- Thursday Prog 3	on/off
		26- Friday Prog 3	on/off
		27- Saturday Prog 3	on/off
		28- Sunday Prog 3	on/off
		29- Start Prog 4	OFF-0-23:50

Level 1	Level 2	Level 3	Value
Menu 02 - Set Chrono (continuing)			
		30- Stop Prog 4	OFF-0-23:50
		31- Monday Prog 4	on/off
		32- Tuesday Prog 4	on/off
		33- Wednesday Prog 4	on/off
		34- Thursday Prog 4	on/off
		35- Friday Prog 4	on/off
		36- Saturday Prog 4	on/off
		37- Sunday Prog 4	on/off
	M-2-4- Program		
		01- Chrono weekend	on/off
		02- Start 1 Weekend	OFF-0-23:50
		03- Stop 1 Weekend	OFF-0-23:50
		04- Start 2 Weekend	OFF-0-23:50
		05- Stop 2 Weekend	OFF-0-23:50
Menu 03- Select			
	01- Italian		set
	02- English		set
	03- Deutsch		set
	04- France		set
Menu 04- Choose Season			
	01- Season		Winter/Summer
Menu 05- Stand-by Mode			
	01- Stand-by Mode		on/off
Menu 06- Buzzer Mode			
	01-Buzzer mode		on/off
Menu 07- Initial Load			
	01- Initial load		90"
Menu 08- Stove State			
	01- Page 1		
		01- Auger Time	info
		02- Thermostat State	info
		03- Power Stove	info
		04- Time load	info
	02- Page 2		
		01- Fumes Temperature	info
		02- Fumes Extractor	info
		03- Air Exchanger Speed	info
	03- Page 3		
		01- Water Temperature	info
		02- Water Pressure	info
		03-Boiler temp/Buffer	info
		04- 3 way valve state	info
Menu 09- Technical			
	01- Access Key		set
Menu 10- Pellet Type			
	01- Pellet Load		-9/+9

Menu 01 - Set Clock

Sets the current time and date. The circuit board comes equipped with a lithium battery that allows the internal clock to have an autonomy of over 3/5 years. To access the general programming menu, press P3, and P3 again on Menu 01. Choose the desired day and press P3. Then set the hour, the minute, month and year. By pressing P1 and P2 to increase or decrease, and to confirm P3.



Menu 02 - Set Chrono

Submenu M-2-1

The menu shown on the “M-2-1 set chrono” display allows you to enable or disable all of the functions of the programmable thermostat in one go. To enable them, press P3 and then either P1 or P2 for On or Off respectively. Confirm by pressing P3.

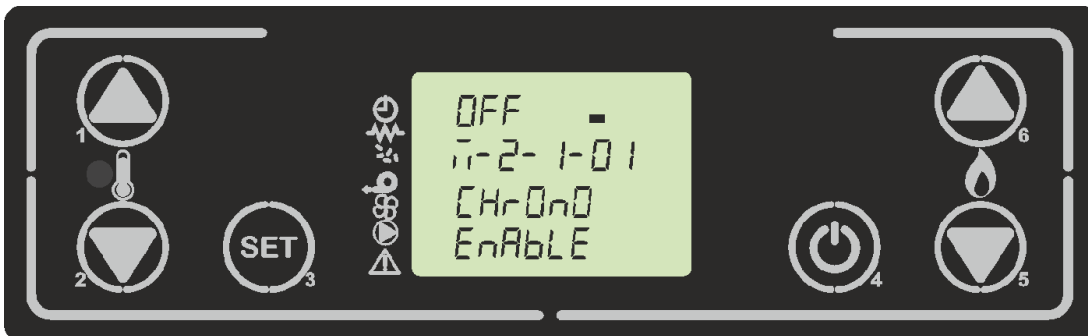

Submenu M2-2

Select the menu “M2-2 program day” and press P3 to see and enable or disable the various parameters for programming the daily chrono settings . It is possible to set two functioning slots, the first with START1 Day and STOP1 Day and the second with START2 Day and



STOP2 Day. These slots can be defined according to the timings set out, where the OFF setting tells the clock to ignore the command. To modify, use P1 (to go up) and P2 (to go down). Confirm with P3. To go to next chrono set press P5 or P6.

Submenu M2-3

The “M-2-3 Program Week” menu allows you to enable or disable and set the weekly programmable thermostat. The weekly function has 4 independent programs. Additionally, pressing OFF on the timetable will tell the system clock to ignore the corresponding command.

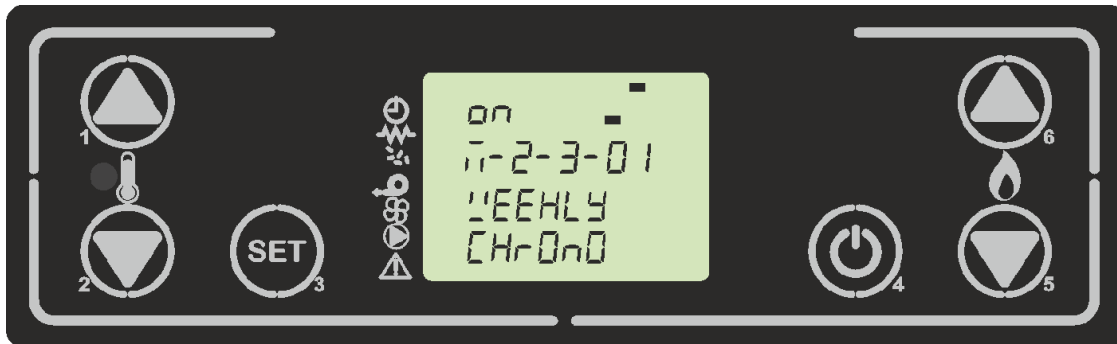

Submenu M2-4

Allows you to enable/disable and set the programmable thermostat functions on the weekend (days 6 and 7, or Saturday and Sunday). To enable, press P3 on the “chrono week-end” item and select “on” by pressing P1 (to go up) or P2 (to go down) and on the display segment light. Selecting the times under Start 1 weekend and Stop 1 weekend will set the times that the heater will function on Saturday, while Start 2 weekend and Stop 2 weekend will set the operating times for Sunday.

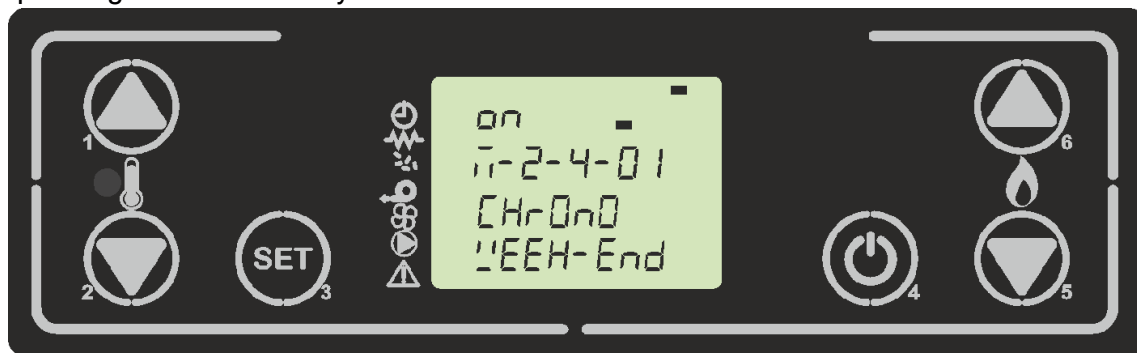

Menu 03 - Language Selection

Allows you to set the language from those available. To move to the next language, press P1 (to go up) and to go back press P2 (to go down). To confirm and go back press P4.



Menu 04 - Choose Season

It allows the selection of the season so that the whole heating part is not considered during the summer season. To go from winter to summer and vice versa press either P2 or P1. To confirm and exit, press P4.



Menu 05 - Standby Mode

Allows you to enable or disable Standby mode. Once you have selected the M5 menu using the P3 key, press P1 (to go up) or P2 (to go down) to switch between ON and OFF and vice versa.

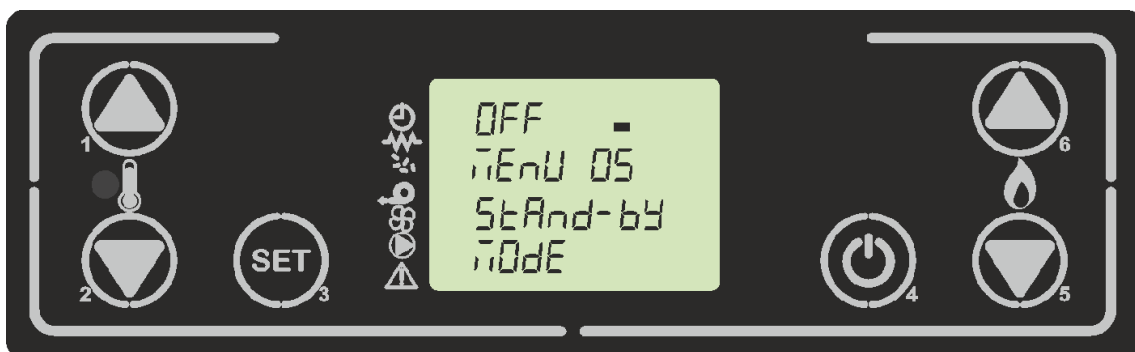

Menu 06 - Buzzer Mode

Allows you to enable or disable the buzzer on the controller.

Menu 07 - First Charge

This function is only available when the heater is **OFF**. It allows the feed screw to load at the first start of the heater when the pellet tank is empty. After selecting the Menu 06 press P1 (to increase). The ventilator will turn on at maximum speed, the feed screw will turn on and remain on until the end of the time shown on the display.

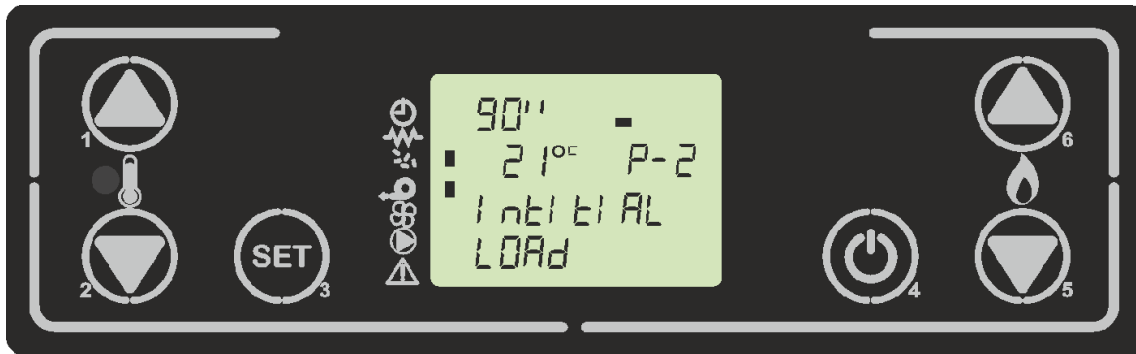

Menu 08 - Stove Status

In menu 08, the display will show the status of several variables during the operation of the stove. The table below shows variables in the display. The same displays are held by pressing the individual buttons P1, P2, P5, P6 for a few seconds.

Menu 09 - Technical Settings

This item in the menu is accessible only to the technician who installed the heater.

Menu 10 - Pellet Type

Pressing P1 or P2 will modify the pellet loading percentage up to a maximum value of +9 and down to a minimum value of -9. Each step increases or decreases it by around 3% of the total period of the feed screw, with respect to the default period (pellet type = 0). The T-ON AUGER time does not change.

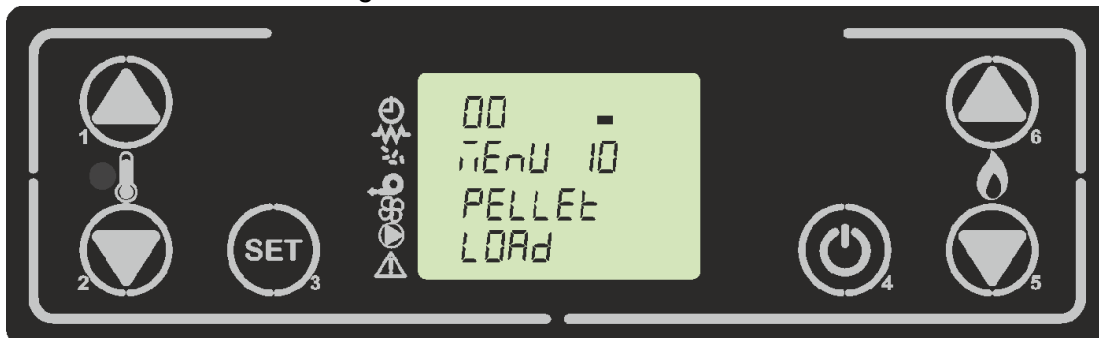

WARNING

- During periods of disuse, the stove must be unplugged. For greater safety, especially if there are children around, we recommend removing the supply cable from the rear of the stove.

NOTICE

- The stove will be subject to expansion and contraction during the start-up and cooling phases, therefore light creaking noises may be heard. This is absolutely normal as the structure is made of laminated steel and must not be considered a defect.
- It is extremely important to make sure the product is not immediately overheated and the temperature is increased gradually, initially using low power. This will prevent damaging the welds and the steel structure.
- Avoid touching the stove during the initial start-up, as the paint in this stage hardens; by touching the paint, the steel surface may be exposed.
- After a long period of inactivity, remove any pellets left in the hopper (using a vacuum cleaner with a long pipe), as they could have absorbed moisture, thereby altering their original characteristics and no longer being suitable for combustion.

9 SAFETY DEVICES

The product is supplied with the following safety devices

AIR PRESSURE SWITCH

Monitors pressure in the smoke duct. It is designed to shut down the pellets feed screw in the event of an obstructed flue or significant back-pressure (wind).

WATER PRESSURE SWITCH

If water pressure drops below 0,2 bar in the circuit, stove is not operated to protect the product and the pump being fired without water.

SMOKE TEMPERATURE PROBE

Detects the temperature of the smoke, there by enabling start-up or stopping the product when the temperature drops below the preset value.

CONTACT THERMOSTAT IN THE BOILER

If the temperature exceeds the preset safety level, it immediately shuts down stove operation.

WATER TEMPERATURE PROBE

If the water temperature approaches the shutdown temperature (85°C) the probe makes the boiler perform the "OFF Stand-by" automatic shutdown.

ELECTRICAL SAFETY

The product is protected against sudden current surges by a main fuse in the power supply panel on the rear part of the product. Other fuses that protect the electronic boards are found on the latter.

SMOKE FAN

If the fan stops, the electronic board promptly shuts off the pellets supply and an alarm message is displayed.

GEAR MOTOR

If the gear motor stops, the boiler will continue to run until the flame goes out due to lack of fuel and until a minimum level of cooling is reached.

TEMPORARY POWER CUT

If the power cut lasts less than 10" the stove returns to its previous operating status; if it lasts more it carries out a cooling/restart cycle.

FAILED START-UP

If during ignition no flame develops, the boiler will go into alarm condition.

ANTIFREEZE FUNCTION

If the probe in the boiler detects a water temperature of less than 5°C, the circulation pump is automatically activated to prevent the system from freezing.

PUMP ANTI-SEIZURE FUNCTION

If the pump is not used for prolonged periods, it is activated periodically for a few seconds to prevent it from seizing up.

10 CLEANING AND MAINTENANCE

10.1. Daily cleaning performed by the user

Burning Pot

Remove the burning pot and burning pot ring from the relevant compartment and free the holes using the appropriate fire irons supplied, remove the ash from the burning pot using a suction device. If the pellets in the hopper finish, unburned pellets may accumulate in the burning pot. Always empty the residue in the burning pot before starting-up.

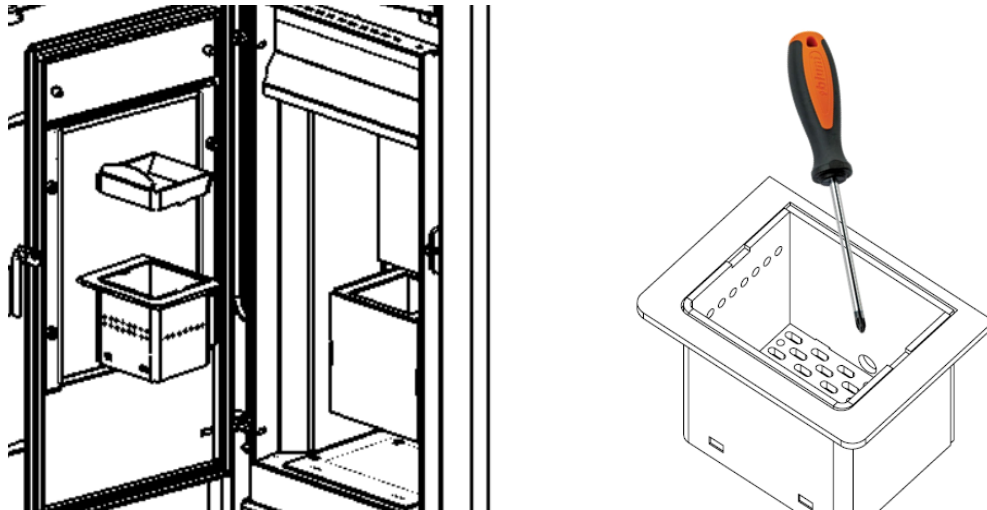

NOTICE

- REMEMBER THAT ONLY A CORRECTLY POSITIONED AND CLEAN BRAZIER CAN GUARANTEE START-UP AND OPTIMAL OPERATION OF YOUR PELLET BOILER.

Heat Exchanger

Cleaning of heat exchanger allows guarantee constant heat output through operation life. This type of maintenance must be performed at least once a day. To do this, just use the relevant scrapers positioned in the upper part of the stove, moving them up and down several times.

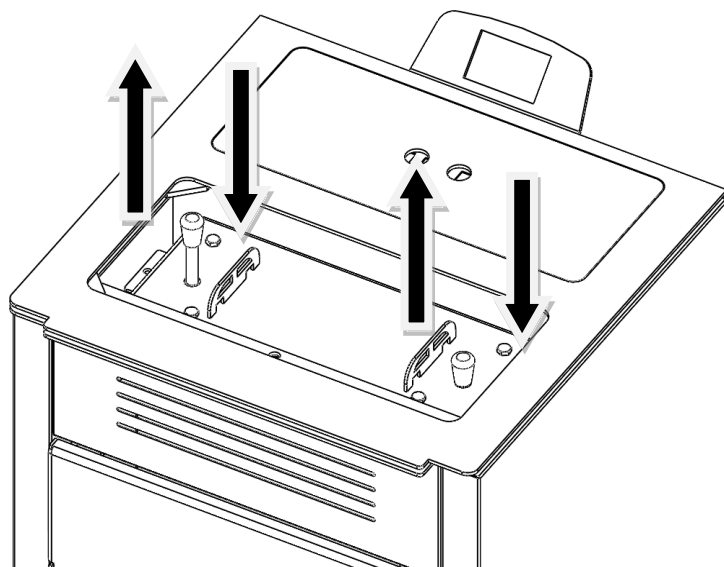

10.2. Checks to be performed every 2/3 days

Ash Pan and Combustion Chamber

Remove the ash pan and clean the compartment around the brazier from ash paying attention to hot ashes. **Only if the ash is completely cold**, a vacuum cleaner can be used to remove it. Use a drum-type vacuum cleaner that is suitable for picking up particles of a certain size. Experience and the quality of the pellets will determine the cleaning frequency required. **However, it is recommended not to exceed 2 or 3 days.**

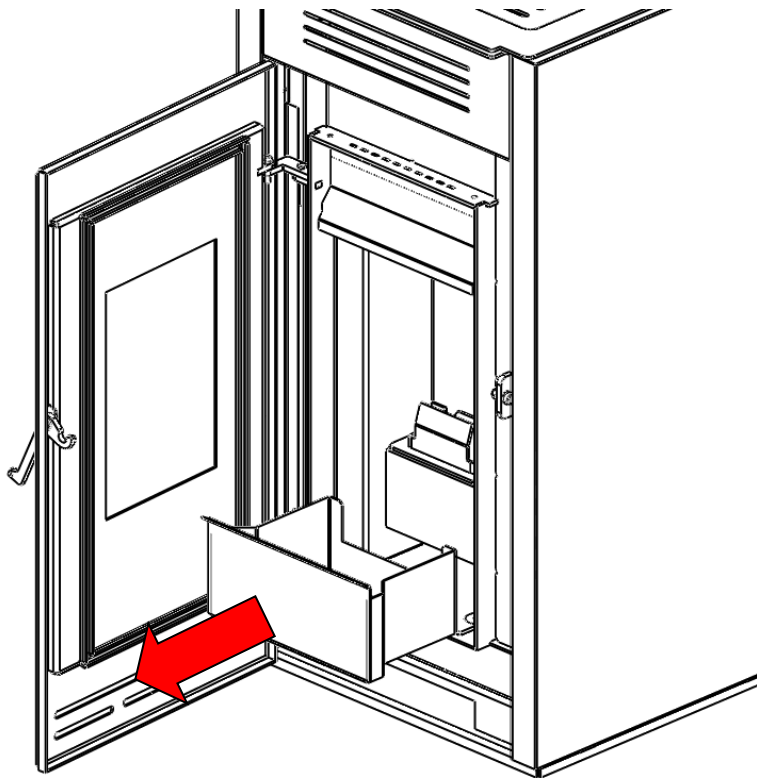

NOTICE – Disposal of ashes

- The ashes should be placed in a metal container with a sealed cover. The sealed container should be placed on a noncombustible surface at a safe distance from combustible materials until the cinders have been completely extinguished.
- Only when they have been fully extinguished can the ashes be thrown away with organic waste, assuming that nails or other nonorganic material are not present.
- Make sure that the ash is completely cold before emptying it into a suitable container.

Cleaning the Glass

Clean the glass with a damp cloth or damp paper rubbed in ashes. Rub the glass until it comes clean. Although it is likely that tar will build up on the glass during the lighting stage, it will burn off with the stove in full operation. If, however, the tar is left to build up over a long period it will require more effort to remove. We therefore recommend that the glass be cleaned daily before lighting the stove.

NOTICE

- Do not clean the glass while the stove is working and the glass is HOT; do not use abrasive sponge and corrosive substance such as solvents.

10.3. Monthly cleaning

Smoke Chamber

Proceed with cleaning the smoke chamber.

- Remove the ash pan.
- Using the Allen wrench provided in the kit, loosen the screws fastening the smoke chamber bottom plate (the screw need not be fully removed).
- Grasp the smoke chamber bottom plate, slide it towards the front of the appliance, lift it and remove it.
- Now clean the actual smoke chamber: remove the deposited ash and combustion products also from under the flue gas ducts at the sides of the smoke chamber

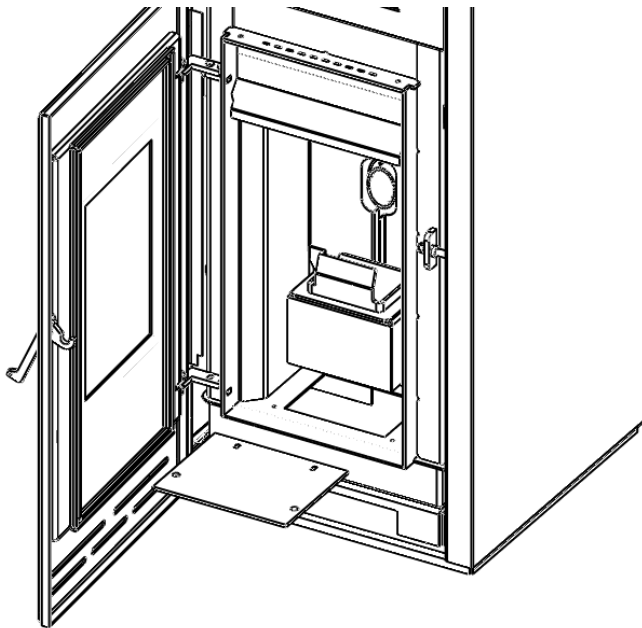

10.4. Periodic maintenance

The scheduled maintenance work listed below must be carried out ONCE A YEAR and prior to starting up the appliance or after a long period of inactivity. This work is necessary to ensure that the appliance remains efficient and safe.

- Thorough cleaning of the smoke chamber.
- Check and clean the smoke outlet and flue system.
- Clean away dust and cobwebs from the area inside the cladding.
- Clean moving parts and mechanisms (motors and circulation pump).
- Check the electrical part as well as the connected electronic and water circuit components.
- Check the water level and pressure of the water system, resetting the values, and if necessary bleed the valves and radiators.
- Check that the circulation pump impeller is in proper working order. If it is locked, unscrew the plug from the circulation pump and release the impeller with a screwdriver.

- Check the tightness and state of the gaskets/seals of the glass door, the water system and all the elements subject to wear and if necessary replace.
- Check the seal and tightness of the joints and connecting pipes.
- Check the state of the temperature/pressure relief and safety valves and if they have been activated. Check that they are in proper working order and if necessary replace.
- Carry out all maintenance and checks required for correct operation and adaptation to safety regulations.
- Light the stove in accordance with instructions given in the paragraph.

NOTICE

- **All cleaning and maintenance must be carried out with the power cable disconnected from the power supply.**

Cleaning the Flue System

Until you have got reasonably used to the operating conditions of the stove, we recommend that this maintenance be carried out on a monthly basis. Remove the plug from the Tee and clean the pipes. If necessary, particularly on the first few occasions, we recommend calling in a qualified technician.

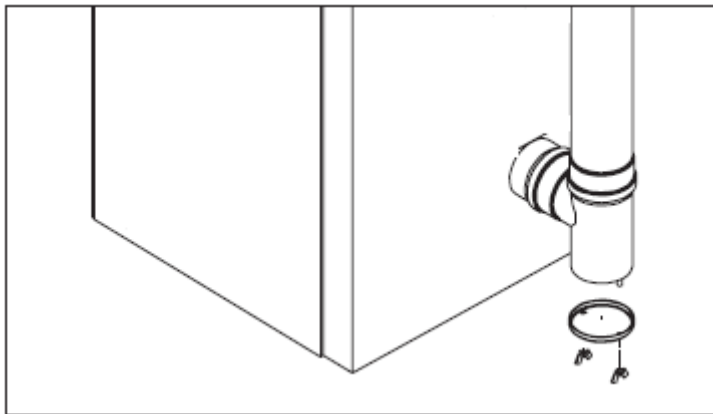

Cleaning the smoke duct and general checks

Clean the smoke exhaust, especially around the T-fittings, curves and any horizontal sections. For information on cleaning the flue, contact a chimney sweeper. Check the tightness of the ceramic fibre gaskets on the boiler door. If necessary, order new replacement gaskets from the retailer or contact an authorized service centre to carry out this task.

NOTICE

- The frequency with which the smoke exhaust must be cleaned depends on the use of the boiler and the type of installation.
- We recommend contacting an authorised service centre for end-of-season maintenance and cleaning as the above-mentioned operations will be performed together with a general inspection of the components.

End-of-season shutdown

At the end of season, before shutting down the boiler, we recommend completely removing pellets from the hopper with the use of a vacuum cleaner with an extension.

11 ALARMS AND TROUBLESHOOTING

If a problem is detected during operation, the stove will intervene and alert you by turning on the alarm LED and making a noise. The following alarms could sound:

Origin of Alarm	Display
Black-out	AL 1 OUT
Flue gas temperature probe	AL 2 FUME PROBE
Flue gas over-temperature	AL 3 HOT FUME
Flue encoder damaged	AL 4 FAN FAILURE
Ignition failure	AL 5 FAILED IGNITION
Pellet absence	AL 6 NO PELLETT
Thermal safety overtemperature	AL 7 THERMAL SAFETY
Depression absence	AL 8 FAILURE DEPRESS-
Water probe	AL 9 PROBE H2O
Overtemperature water	AL A HOT WATER
Water pressure	AL B WATER PRESSURE

Every alarm causes the stove to immediately shut down! State of alarm occurs after reaching a pre-set time, **EXCEPT FOR THE BLACKOUT ALARM**, and can be reset by pressing and holding the P4 key. For security reasons, each time you reset an alarm, the heater will automatically be turned off. When the alarm is activated, the segment alarm LED will turn on and, where enabled, the buzzer will buzz intermittently. If the alarm is not reset, the heater will turn itself off and the display will continue to show an alarm message.

Black-out

During the heater's work mode, it might run out of energy. When it restarts, if the blackout period was less than 30 seconds, the heater will re-enter the WORK mode; otherwise, the alarm will sound. The stove will turn itself off.

Smoke Temperature Alarm

The alarm will sound if the exhaust probe is faulty. The stove will turn itself off.

Smoke Over-Temperature Alarm

The alarm will go on if the exhaust probe reaches a temperature higher than the fixed, unalterable value given in the parameters. The stove will turn itself off.

Smoke Encoder Alarm

The alarm will sound if the air ventilator is faulty.

Ignition Failure Alarm

The alarm will go on when the heater fails to turn on properly, i.e. if, within the period of time given for ignition, the smoke temperature does not rise above the pre-set parameter. The alarm will show on display and stove turn off itself.

Pellet Absence Alarm

In work mode, if the fumes temperature drops below 40°C, the alarm will sound. The alarm will show on display and stove turn off itself.

Over Temperature Thermal Safety Alarm

The alarm will sound when the general security thermostat reaches a temperature higher than 95°C. The thermostat will intervene and turn off the feed screw, the control will indicate on display and the stove will turn off itself.

Depression Failure Alarm

The alarm will go on when the water pressure switch reaches a pressure reading lower than 0,2 bars. The pressure switch will turn off the feed screw and the stove will turn off itself.

Water Probe Alarm

The alarm will go on if the water probe is not connected in the circuit. The stove will turn itself off.

Overtemperature Water Probe

The alarm will sound if the water probe reaches a temperature higher than the fixed (85°C) reached in a very short time. The stove will turn it self off.

Stove is not Firing-up Automatically (Needs daily cleaning too often)

If the stove can't fire up more than a few times without cleaning and needs cleaning in a few hours of working, it means there could be a problem about fuel or air input or chimney. Please be sure that the air input of the stove is not blocked by any material. To check origin of problem and solve it, please refer to the following steps:

1. Perform a cleaning explained on section 10.1 (each day or every 2 days)
 2. Fire up the stove and watch until the stove burns up. Check for pellet level on a few stages.
- After preloading of pellets and starting to load pellet/wait fire, how high is the pellet level in the burning pot? It must be close to igniter hole. If it's more than that level, it means there is too much pellet loading while burning up. This happens because of the length or diameter of the pellets. It's necessary to make pellet type optimization.
 - If there is no problem on preloading section, please keep watching the pellet level until stove goes to maximum power. After you see the fire, if fuel level increases or fuel level goes up to secondary air holes level of burning pot on any stage (before or after fire presents), it means that less air is going into burning pot than stove needs (could be low draft on chimney or blockage on air input of the stove). Please check the air input of the stove, perform a cleaning explained on section 10.3 (Monthly Cleaning) and check the chimney installation explained on Chapter 5. If the chimney is properly installed, be sure it's clean too. After that, please retry to start the stove and check for the same process again. If there is still a problem, it's necessary to make chimney type optimization.

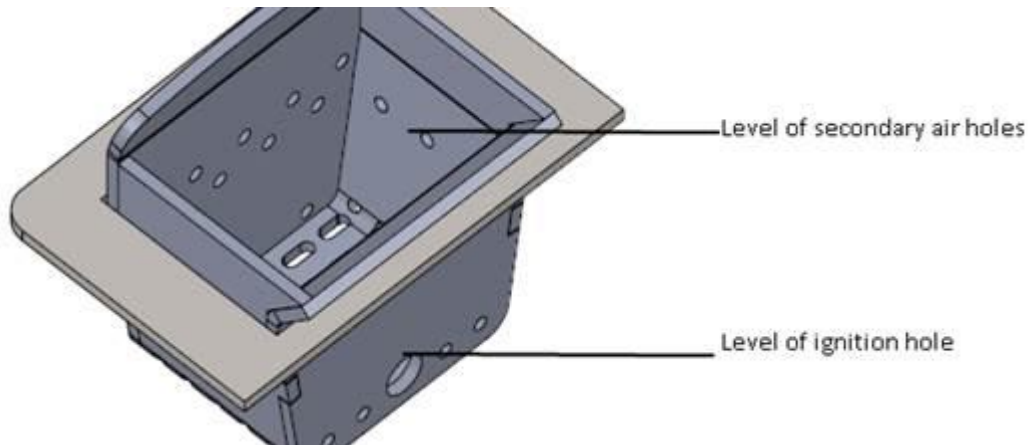

Pellet Type Optimization and Chimney Type Optimization

WARNING

The following section is reserved for professional technicians with specific knowledge concerning the product. Random changes in the settings could cause severe damage to the stove, people and the environment. For this, producer assumes no responsibility.

To go to the Pellet Type Menu, enter the main menu by pressing the P3 key. Move up and down using P5 and P6 until you see M10 "PELLET TYPE" and press P3 to enter.

P1 or P2 will modify the pellet loading percentage up to a maximum value of +9 and down to minimum value of -9. Each step increases or decreases it by %3 of the total period.

To get to the technical menu, enter main menu by pressing the P3 key. Move up and down using P6 and P5 until you see MENU 09 "Technical Settings" and press P3 to enter. Next, press P1 or P2 (press and hold to scroll fast) to enter the access key A9. Press P3 to confirm the access key and to access the submenu where you can configure the various parameters of the stove.

Pellet Type Optimization:

This optimization has 2 steps:

First, the preload time must be optimized. From M9-2, General Setting menu, you can adjust the preload time with Pr40 (M-9-2-03) parameter. Pellet level on burning pot after preload must be close to burning pots ignition hole upper level. Since the problem is over loading, pellet loading time must be decreased. Please note the original value and the adjusted value.

Second, work phase must be adjusted with noted values. To adjust that, please use following formula and following changes.

$$\text{Percentage} = ((\text{Adjusted value} / \text{Original value}) - 1) \times 100$$

Adjust the Pellet Type from M10 Pellet Type menu. Pressing P1 or P2 will modify the pellet loading percentage up to a maximum value of +9 and down to a minimum value of -9. Each

step increases or decreases it by 3% of the total period of the feed screw with respect to the default period (Pellet Type=0).

For example:

Noted parameters are:

Original value = 50

Adjusted value = 41

Calculations:

Percentage = $((41 / 50) - 1) \times 100 = (0,82 - 1) \times 100 = - 18 \%$

Pellet Type = $-18 / 3 = -6$

Set Pellet Type to -6

Chimney Type Optimization:

This optimization has 2 steps:

First, ignition fan speed must be optimized. Since the problem is pellet level is increasing on the burning pot, fan speed must be increased before work phase. From M9-4 Settings Factory menu you can increase Pr16 (M-9-4-16) and Pr17 (M-9-4-17) parameters to adjust fan speed on needed functioning stages. Please note the original and the adjusted parameters.

Second, use the same logic of the percentage formula to adjust the M11 Chimney Type parameter.

Adding Cleaning Phases on Work Phase

After optimizations are made, adding initial cleaning phases will help stove to work for a longer time without daily cleaning needed. To activate the initial cleaning set the following parameters from M9-4 Settings Factory menu.

Pr03 (M-9-4-03) = 10 (Period of cleaning cycle as minutes)

Pr12 (M-9-4-12) = 30 (Fire pot cleaning duration)

Pr29 (M-9-4-29) = 2700 (Fan speed on cleaning as rpm)

Pr30 (M-9-4-30) = (Auger motor ON time on cleaning phase, changes according to stove. Set same as Pr06)

12 FOR INSTALLERS ONLY

12.1. Control board lay-out

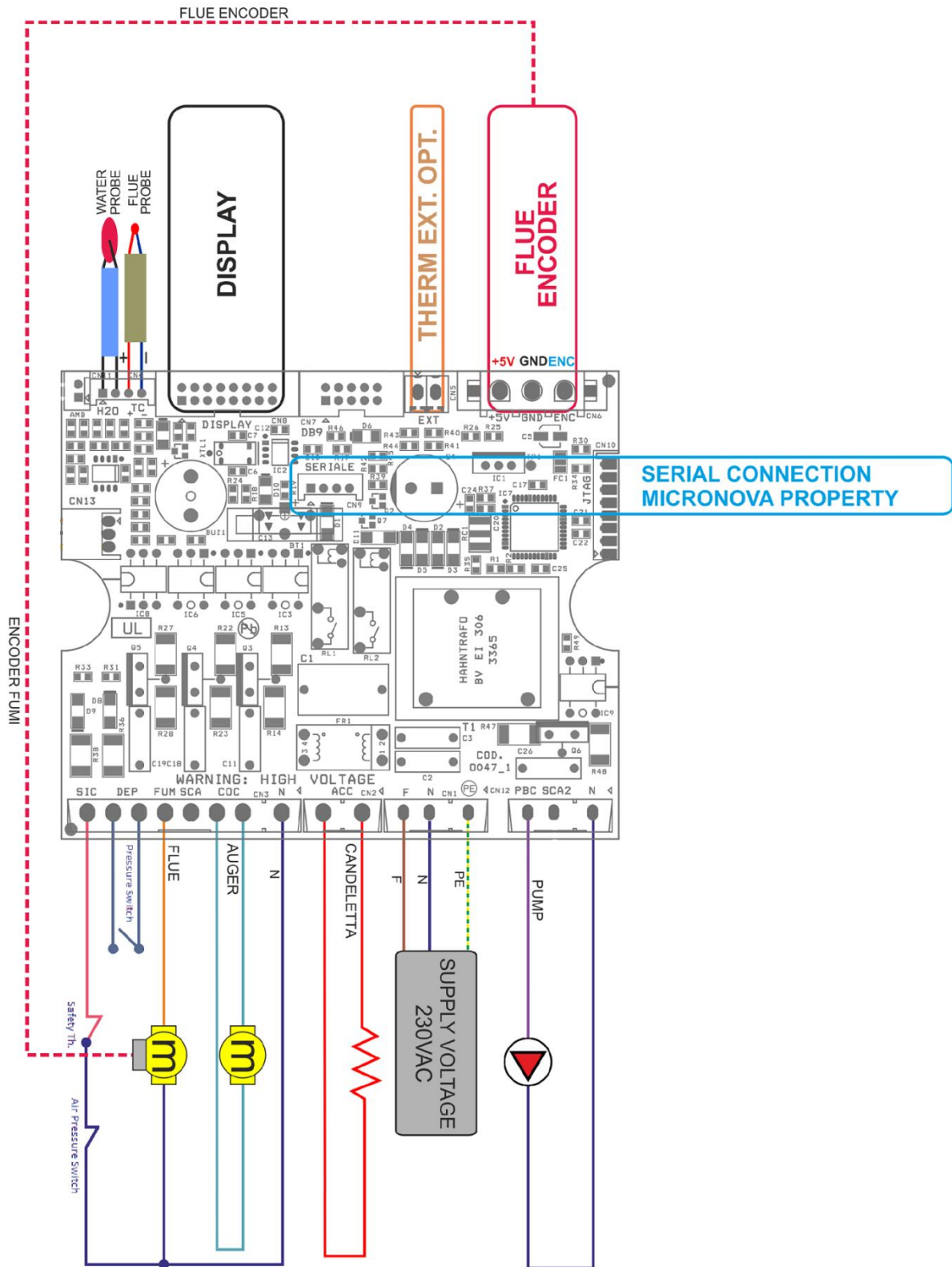

12.2. Description of connectors

Connector	Pin	Label	Description
CN1	1	PE	GROUND
	2	N	NEUTRAL
	3	F	PHASE
CN2	1	COM	NEUTRAL
	2	ACC	IGNITER
CN3	1	N	NEUTRAL
	2,3	COC.	AUGER
	4	SCA.	OPTIONAL MOTOR
	5	FUM	FUME
	6,7	DEP	PRESSURE SWITCH
	8	SIC	THERMAL SAFETY
CN4	1,2	H2O	WATER PROBE (OPTIONAL)
	3	TC+	FUME PROBE +
	4	TC-	FUME PROBE -
CN5	1,2	EXT	OPTIONAL EXTERNAL THERMOSTAT
CN6	1	5V	FUME ENCODER POWER
	2	GND	FUME ENCODER GROUND
	3	ENC	FUME ENCODER SIGNAL
CN7	1,2...10	DB9	EXPANSION 0073
CN8	1,2...16	DISPLAY	CONSOLE
CN9		SERIALE	SERIAL CONNECTION TO BE USED WITH ADAPTOR
CN10		JTAG	FACTORY PROGRAMMING CONNECTOR
CN11	1,2	AMB	ROOM PROBE
CN12	1	N	NEUTRAL
	2	SCA2	OPTIONAL EXCHANGER
	3	PBC	LOW-VOLTAGE PUMP
CN13	1,2,3		LOW-VOLTAGE PUMP (OPTIONAL PWM)

START-UP / COMMISSIONING FORM

1/2

END-USER INFORMATION

NAME / SURNAME	:	_____
ADDRESS	:	_____
CITY / PROVINCE	:	_____
COUNTRY	:	_____
E-MAIL / GSM	:	_____
SIGNATURE	:	_____

PRODUCT INFORMATION

PRODUCT MODEL	:	_____
EXTRAS 1	:	_____
EXTRAS 2	:	_____
INVOICE DATE and NUMBER	:	_____
SERIAL NUMBER	:	_____

COMMISSIONING OF THE DEVICE

DATE OF COMMISSIONING	:	_____
AUTHORIZED COMPANY for COMMISSIONING	:	_____
ADDRESS	:	_____
E-MAIL / GSM	:	_____
SERVISER NAME / SURNAME	:	_____
SERVISER STAMP and SIGNATURE	:	_____

- Warranty period is 2 (two) years, and starts with signing of this document
- One copy of this document shall be handed to end-user
- General checks on next page should be completed for future reference

START-UP / COMMISSIONING FORM

2/2

General Checks	Check	Comments
Wall plug voltage measurement	_____ V (AC)	
There is no damage because of transportation		
Chimney is clean, functioning well and meets the requirements defined in manuals		
Outputs are tested before start-up and working correctly		
Plumbing plant installation is made according to manuals, and necessary sensors are installed		
Optimization for auger / chimney calibration (if needed) is made		
Purchased optional elements are installed correctly, and tested		

End-User Notification	Check	Comments
User is informed about boiler/stove cleaning and service cycles		
User is informed about errors and how to act when they are shown		
User is informed about combustion power selection and setting necessary thermostats		
User is informed about boiler/stove functioning, operating, fuel quality and warranty conditions		

REMARKS / DIFFERENCES

