



Installation and User Manual



2021/R02/Astra_Micronova v2

A S T R A



Dear Customer,

Thank you for having chosen our product.

To allow for optimal operation and for you to enjoy the warmth and sense of wellbeing that the fire can convey in your home, we advise you to read this manual carefully before starting up the product for the first time.

CARE OF THE MANUAL AND HOW TO CONSULT IT

Take care of this manual and keep it in an easily accessible place. Should the manual be misplaced or ruined, request a copy from your retailer or directly from the authorised Technical Assistance Department.

	
DECLARATION OF CONFORMITY According to Regulation (EU) No 305/2011 No. 0117	
Type of the equipment	: Automatically stoked residential space heaters for wood pellets EN 14785:2006
Trademark	: Thermasis
Type designations	: ASTRA 8 / COMET 8
Manufacturer	: BOYSIS MAKINE TAAHHUT SANAYI ve TICARET A.Ş. Şerifali Mahallesi Hüsrev Sokak No.2 Erişkenler Plaza Kat 3, 34775, Istanbul/TURKIYE
Certificate of Conformity released by	: "SZU Engineering Test Institute" Hudcova 424/56 b, 621 00 Brno
With certificate/report number	: 30-15989/1/T
The following harmonised standards or regulations which comply with good engineering practice in safety matters in force within the EU have been applied:	
EN 14785 : 2006 EN ISO 12100 : 2010 EN ISO 13857 : 2008 EN 60335-1 : 2012 EN 60335-2-102 : 2016 2006 / 42 / EC 2014 / 35 / EU	
As manufacture and/or authorised representative within EU, we declare under our sole responsibility that the equipments follow the essential requirements foreseen by the above mentioned regulations	
Signed for and on behalf of the manufacturer by:	
Murat Gedik [Sales Consultant] Bursa, April, 2022	

DECLARATION OF CONFORMITY

According to Regulation (EU) No 305/2011
No. 0111

Type of the equipment : Automatically stoked residential space heaters for wood pellets EN 14785:2006

Trademark : **Thermasis**

Type designations : **ASTRA 12**

Manufacturer : BOYSIS MAKINE TAAHHUT SANAYI ve TICARET A.Ş.
Şerifali Mahallesi Hüsrev Sokak No.2 Erişkenler Plaza Kat 3,
34775, İstanbul/TURKIYE

Certificate of Conformity released by : "ITEM CONSULT" Ltd (NB 1837), Sofia 1220
With certificate/report number :

The following harmonised standards or regulations which comply with good engineering practice in safety matters in force within the EU have been applied:

EN 14785 : 2006
EN ISO 12100 : 2010
EN ISO 13857 : 2008
EN 60335-1 : 2012
EN 60335-2-102 : 2016
2006 / 42 / EC
2014 / 35 / EU

As manufacture and/or authorised representative within EU, we declare under our sole responsibility that the equipments follow the essential requirements foreseen by the above mentioned regulations

Signed for and on behalf of the manufacturer by:

Murat Gedik [Sales Consultant]
Bursa, 1st March, 2021



1 INTRODUCTION

ASTRA is a welded steel air pellet stove with all necessary comfort and safety features packed inside the cabinet. Main features and advantages of ASTRA are as follows:

- Automatic ignition
- PID control, output regulation
- High heat resistant ceramic sight glass with auto cleaning system
- Exhaust fan speed modulation for combustion
- Forced ventilation of room air to increase efficiency
- Air pressure switch (auto stop when there is lack at chimney draught)
- Safety against back burning
- Burning pot made of special stainless steel
- Remote controller

2 WARRANTY CONDITIONS

THE MANUFACTURER guarantees the product, with the exception of elements subject to normal wear (listed below), for a period of 2 (two) years;

- Starting from date of start-up, which is proven by a commissioning document that contains the name of the seller and the date when the sale / first start-up took place
- If there is no service/commissioning report, standard guarantee period starts with the date when the sale took place.

The term 'warranty' refers to the (free-of-charge) replacement or repairs of parts acknowledged to be faulty due to manufacturing defects.

Furthermore, in order for the guarantee to be valid, the product must be installed and calibrated by qualified personnel. Installations that do not meet the current standards, improper use and lack of maintenance as expected by the manufacturer, void the product warranty. The warranty is valid on the condition that the instructions and warnings contained in this manual are observed, and therefore the product is used correctly.

The replacement of the entire system or the repair of one of its components does not extend the warranty period, and the original expiry date remains unchanged.

EXCLUSIONS FROM WARRANTY

Parts subject to normal wear such as gaskets, ceramic glass, cast iron grilles, vermiculite boards, fire bricks, fire stone burners, handles and electric cables, knobs, all parts which can be removed from the firebox, are excluded from the warranty

Any part that may be faulty as a result of negligence or careless use, incorrect maintenance or installation that does not comply with the manufacturer's instructions (see the relative chapters in user manuals of each product).

The warranty will be rendered null and void in the event of damage caused by tampering, atmospheric agents, natural disasters, vandalism, electrical discharges, fire, faults/defects in the electric and/or hydraulic system, and maintenance not being performed at all or as indicated by the manufacturer instructions

Non-regular electrical supplies, and electrical power cuts off too often, can cause severe damage on control system, sensors and actuators of the products carrying those components. We recommend installing 230 V 50 Hz AC voltage regulator for those products. Also installing a UPS for pumps can protect system from electrical cut-offs causing over heating of water.

The warranty does not cover malfunctions and/or damage to the appliance that arise due to the following causes:

- Damage caused during internal transportation and/or handling
- All parts that develop faults due to negligence or improper use, incorrect maintenance, installation that does not comply with the manufacturer's instructions (always refer to the installation manual provided with the product)
- Improper overheating of the equipment, use of fuels not conforming to the types and quantities indicated in the instructions provided
- Further damage caused by incorrect user interventions in an attempt to fix the initial fault
- Worsening of the damage caused by the user continuing to operate the appliance even after the fault has been noticed.
- In case of a boiler/hydro stove, any corrosion, incrustations or breakages caused by water flow, condensation, lack of water in the system, mud or limescale deposits
- Inefficiency of chimneys, flues or parts of the system affecting the appliance.
- Failure to have the annual product maintenance performed by an authorised technician or qualified personnel will result in the loss of the warranty.
- Save for the legal or regulatory limits, the warranty does not cover the containment of atmospheric and acoustic pollution.

THE MANUFACTURER declines all liability for any damage which may be caused, directly or indirectly, to persons, animals or objects as a consequence of non compliance with any provision specified in the manual, especially warnings regarding installation, use and maintenance of the appliance.

SPARE PARTS

Only use original spare parts. The retailer or service centre can provide all necessary information regarding spare parts. We do not recommend waiting for the parts to get worn out before having them replaced. It is important to perform regular maintenance.

The Manufacturer declines all liability if the product and any other accessory is used improperly or modified without authorisation. All parts must be replaced with original spare parts. Warranty cover is valid if the product is installed and tested by a qualified installer, according to the detailed instructions provided in the instruction manual supplied with the product. The term 'warranty' refers to the (free-of-charge) replacement or repairs of parts acknowledged to be faulty due to manufacturing defects.

3 SAFETY WARNINGS

- Installation, electrical connection, functional verification and maintenance must only be performed by qualified or authorized personnel. Install the product in accordance with all the local and national laws and standards applicable in the relative place, region or country.
- Only use fuels recommended in this manual. Do not put any fuel other than wood pellets in the hopper. Keep cover of the fuel hopper always closed.
- It is strictly forbidden to use alcohol, petrol, liquid fuel for lanterns, diesel, bioethanol, fluids for lighting charcoal or similar liquids to light/rekindle the flame in these devices. Keep these flammable liquids well away from the appliance.
- Do not place laundry on the product to dry. Any clothes or similar objects including the fuel must be kept at a safe distance from the product.
- Any type of tampering or unauthorized replacement with non-original spare parts could be hazardous for the operator's safety and relieve the producer/re-seller from any civil and criminal liability.
- Most of the surfaces of the product are very hot (door, handle, glass, smoke outlet etc.). Avoid contact with these parts unless adequate protective clothing is worn or appropriate means are used, such as heat protective gloves or cold handle type operating systems. It is forbidden to operate the stove with door open or glass broken.
- **THE PRODUCT MUST BE POWERED BY A SYSTEM THAT IS EQUIPPED WITH AN EFFECTIVE EARTH SYSTEM.**
- Switch the product off in the event of a fault or malfunctioning.
- Accumulated unburned pellets in the burner (fire pot) after each "failed start-up" must be removed before starting up again.
- Do not wash the product with water. The water could get inside the unit and damage the electrical insulation and cause electric shocks.
- Do not climb on or lean on the product.
- **INSTALL THE PRODUCT IN ROOMS THAT ARE ADEQUATELY PROTECTED AGAINST FIRE AND EQUIPPED WITH ALL THE UTILITIES SUCH AS SUPPLIES (AIR AND ELECTRICITY) AND SMOKE OUTLETS.**
- If a fire breaks out inside the chimney, switch the appliance off, disconnect it from the mains and do not open the door. Then contact the competent authorities.
- If the ignition system is faulty, do not force ignition with flammable materials.
- Special maintenance must only be performed by authorized and qualified personnel.
- Do not stand for a long time in front of the product in operation. Do not overheat the room where the product is installed. This could cause injuries and health problems.
- Do not to remove the feet that support the product in order to guarantee adequate insulation, especially if the flooring is made of flammable materials.

WARNING – Allowed user for the product

- This appliance can be used by children aged 10 years and above and persons with reduced physical, sensory or mental capabilities or lack of experience and knowledge if they have been given supervision or instruction concerning use of the appliance in a safe way and understand the hazards involved. Children must not play with the appliance. Cleaning and user maintenance shall not be carried out by children without supervision.

DANGER – Risk of electric shock

- Switch off the system before performing work on the stove.
- **THIS APPLIANCE MUST BE EARTHED !**

NOTICE – First operation

- It is quite normal to smell water vapour contained in the special coating of combustion unit of the product. This smell will go out through chimney after a few hours of first operation, and it should not be considered as a product defect.

4 MAIN PARTS AND SPECIFICATIONS

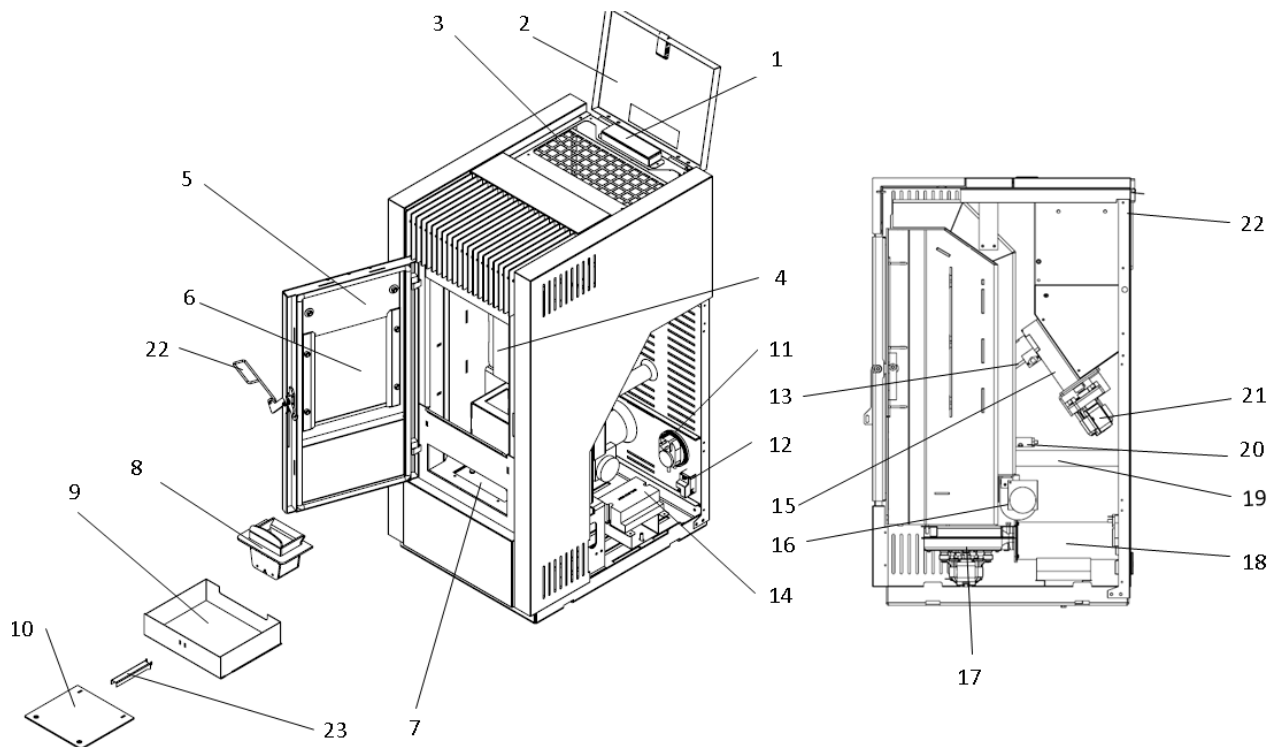

1	User interface and command display	13	STB
2	Fuel loading cover	14	PCB (main controller)
3	Fuel loading grid	15	Feeding screw
4	Combustion chamber / protective board	16	Room air ventilation fan
5	Front door	17	Combustion fan
6	Ceramic glass / inspection window	18	Exhaust outlet pipe
7	Smokehood section	19	Combustion air inlet pipe
8	Burning pot	20	Igniter
9	Ash tray	21	Pellet feeding motor
10	Smokehood / ash cleaning cover	22	Apparatus to open front door
11	Air pressure switch	23	Handle for ash tray
12	Main switch port		

Model		ASTRA 6	ASTRA 8
Product definition		Residential space heating appliances fired by wood pellets EN 14785	
Fuel parameters		Wood pellets size 6 mm Fuel parameters shall comply to EN 14961	
Nominal heat output	kW	6,59	8,45
Efficiency at nominal heat output	%	90,7	90,45
Fuel consumption at nominal heat output	kg/h	1,44	1,85
CO content (13% O ₂) at nominal heat output	%	0,027	0,0157
	mg/m ³	334	196
Flue temperature at nominal heat output	°C	134	123
Mass flow in flue at nominal heat output	gr/s	5,4	6,9
Requested draught at chimney	Pa	8	10
Reduced heat output	kW	3,2	3,96
Efficiency at reduced heat output	%	88,5	92,2
Fuel consumption at reduced heat output	kg/h	0,7	0,92
CO content (13% O ₂) at reduced heat output	%	0,03	0,02
	mg/m ³	380	242
Flue temperature at nominal heat output	°C	96	96
Mass flow in flue at reduced heat output	gr/s	2,8	3,3
Requested draught at chimney	Pa	6	8
Distance to combustible materials	(Rear)	mm	150
	(Sides)	mm	200
	(Front)	mm	800
Autonomy (nominal - reduced heat output)	h	18 - 25	11 - 23
Maximum power rating	W	394	
Power rating at work	W	114	
Supply voltage and frequency	V/Hz	230/50	
Fuel tank capacity	kg	18	21
	lt	26	30
Weight	kg	85	88
External dimensions	H	mm	915
	W	mm	430
	L	mm	550
	Flue outlet diameter	mm	Ø 80
	Fresh air intake diameter	mm	Ø 35

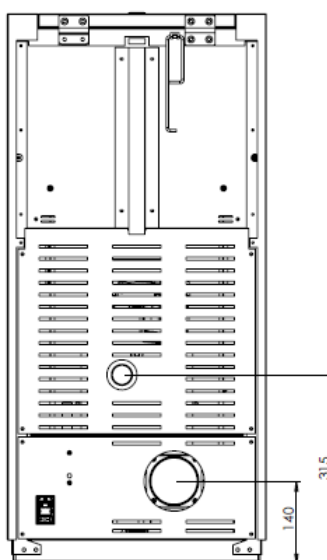
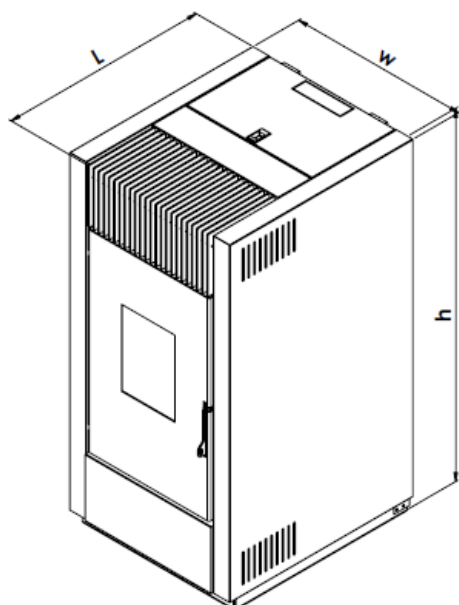

Model	
Product definition	
Fuel parameters	
Nominal heat output	kW
Efficiency at nominal heat output	%
Fuel consumption at nominal heat output	kg/h
CO content (13% O ₂) at nominal heat output	%
	mg/m ³
Flue temperature at nominal heat output	°C
Mass flow in flue at nominal heat output	gr/s
Requested draught at chimney	Pa
Reduced heat output	kW
Efficiency at reduced heat output	%
Fuel consumption at reduced heat output	kg/h
CO content (13% O ₂) at reduced heat output	%
	mg/m ³
Flue temperature at nominal heat output	°C
Mass flow in flue at reduced heat output	gr/s
Requested draught at chimney	Pa
Distance to combustible materials	
(Rear)	mm
(Sides)	mm
(Front)	mm
Autonomy (nominal - reduced heat output)	h
Maximum power rating	W
Power rating at work	W
Supply voltage and frequency	V/Hz
Fuel tank capacity	kg
	lt
Weight	kg
External dimensions	
	H mm
	W mm
	L mm
Flue outlet diameter	mm
Fresh air intake diameter	mm

ASTRA 12	
Residential space heating appliances fired by wood pellets	
Wood pellets size 6 mm EnPlus A1 or A2 to ISO 17725-2	
	11,5
	88,4
	2,55
	0,005
	62
	161
	9,9
	10
	5
	91,8
	1,06
	0,015
	189
	84
	4,1
	5
	150
	200
	800
	11 - 23
	394
	114
	230/50
	30
	44
	118
	1070
	475
	585
	Ø 80
	Ø 50

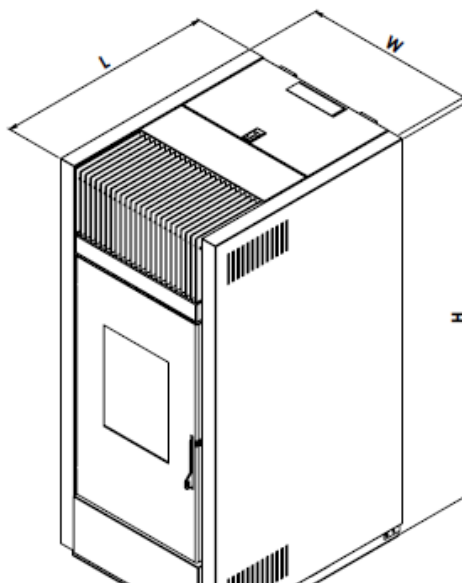
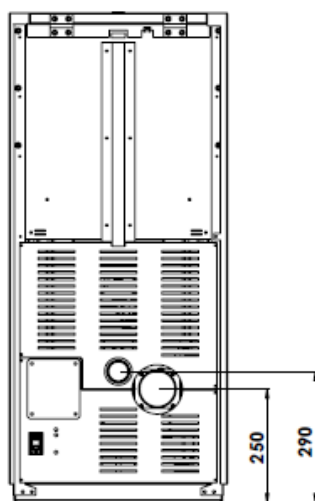

5 BEFORE INSTALLATION

5.1. Fuels

Pellets must comply with Class A1 or A2 according to EN 14961-2

Diameter (mm)	6 ± 1
Length (mm)	Max 40
Moisture (w)	≤ 10%
Ash (w)	≤ 1,5%
Net Calorific Value (kWh/kg)	≥ 4.4

To guarantee combustion without problems, pellets must be kept in a dry place. Poor quality pellets or others that do not comply with that specified previously compromises the operation of your product and can therefore render the warranty and product liability null and void.

5.2. Room selection / operating environment

The product must be installed in a suitable place for regularly operation and routine maintenance. The site must be:

- Compliant for proper operation.
- Equipped with an adequate smoke expulsion system. The product must be connected to a chimney or an internal/external vertical duct that complies with the regulations in force.
- The product must be positioned in such a way that the electrical socket is accessible.
- Equipped with ventilation intake from outside.
- Equipped with 230V 50 Hz power supply with an EC compliant earth system.
- Operating environment must ensure the following regulations unless any local regulation in force request different conditions
 - **The volume of the room where the product is installed should be no less than 15 m³. Air must enter through permanent openings made in the walls (near the product) that reach outwards with a minimum section of 80 cm² without the protective grille. In the case of ducting, up to 3.5 linear meters, increase the cross-section by about 5%, whereas for longer ducts, increase it by 15%. These openings (air inlets) must be made in such a way that it is impossible for them to be obstructed in any way. The opening must be positioned in the lower part of an outer wall, preferably opposite to that in which the smoke evacuation duct is located.**
 - Air can also be drawn from adjacent rooms to the one that is to be ventilated, provided they have an external air inlet and are not used as a bedroom or bathroom or where there is a fire hazard, such as: garages, timber storerooms, warehouses of flammable materials, observing under all circumstances the the provisions of all the applicable standards in force.

- The adjacent room from which air is taken must not have a low pressure compared to the exterior due to a counter draught caused by the presence in that room of another appliance in use or of a suction device.

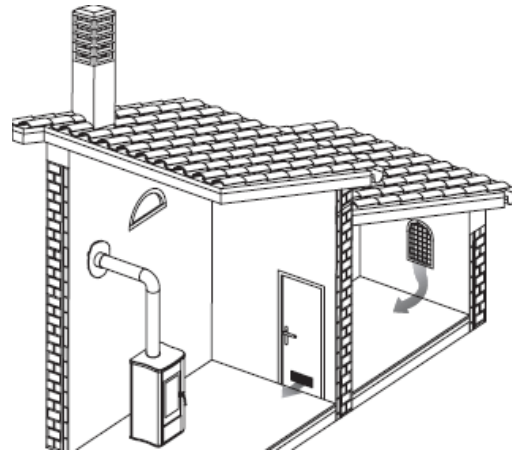

NOTICE

The product cannot be installed

- in bedrooms or bathrooms;
- in rooms where there are liquid fuel appliances with continuous or intermittent operation that draw the combustion air from the room they are installed in;
- in rooms where there are B-type gas heating appliances, with or without domestic hot water production and interconnecting rooms;
- where another heating appliance is installed without an independent air flow.

It is recommended to install the stove detached from any walls and/or furniture, with a minimum clearance to allow effective aeration of the appliance and a good distribution of heat in the room. Observe the distances from flammable or heat-sensitive objects (sofas, furniture, wood panelling, etc.) as specified below. If particularly delicate objects are present, such as furniture, curtains or sofas, increase the stove clearance accordingly.

REFERENCES	COMBUSTIBLE OBJECTS	NON-COMBUSTIBLE
A	150 mm	100 mm
B	200 mm	100 mm

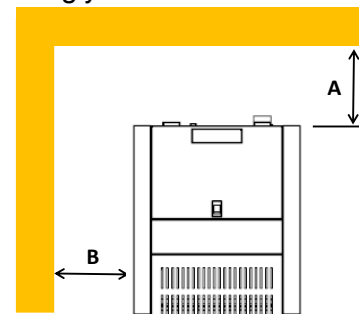

If the floor is made of combustible material, it is recommended to use protection made of non-combustible material (steel, glass...) that also protects the front from falling combusted material during cleaning operations.

The appliance must be installed on a floor with adequate load capacity. If the existing construction does not meet this requirement, one must take appropriate measures (for example a load distribution plate).

WARNING

- Heat-sensitive or flammable objects cannot be placed near the product. Keep such objects at a minimum distance of 80 cm from the outermost point of the product.
- Leave minimum 80 cm free space in front of the stove for loading, and cleaning of combustion unit.

5.3. Connection of the smoke exhaust duct

When making the hole for the passage of the smoke discharge pipe, one must take into account the possible presence of flammable materials. If the hole must be made through a wooden wall or thermolabile material, the INSTALLER MUST first of all use the appropriate wall fitting (minimum diameter 13 cm) and suitably insulate the pipe of the product that passes through it using adequate insulating materials (1.3 - 5 cm thick with minimum thermal conductivity 0.07 W/m°K). The same minimum distance must be applied if the pipe of the product must pass through vertical or horizontal sections near the thermolabile wall. It is recommended to use an insulated double-wall pipe in external sections in order to prevent condensation from forming. Note that the combustion chamber works in negative pressure.

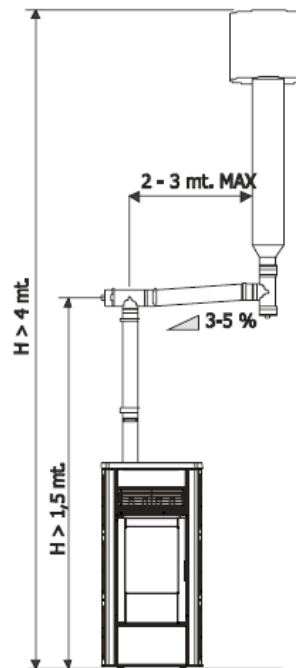

WARNING

- Always use pipes and fittings with appropriate seals that guarantee tightness.

NOTICE

The following conditions must be complied with when connecting the appliance to the chimney:

- The smoke duct must be at least category T200 (or higher if required by the smoke temperature of the appliance) and P1-type (airtight).
- All 90° angles (max. 3) in the smoke exhaust duct must be preferably fitted with the relative T-fittings with inspection hole.
- It is strictly forbidden to fit a mesh at the end of the exhaust pipe as it could cause the product to malfunction (due to clogging).
- It is forbidden to use counter-sloping pipes.
- The horizontal section of the smoke duct must not be longer than 2-3 m.
- It is also recommended not to exceed 6 meters in length with the pipe Ø 80 mm.
- The smoke duct must not cross rooms in which it is forbidden to install combustion appliances.

5.4. Connection to the chimney

The chimney must comply with the following requirements:

- Be waterproof and thermally insulated.
- Be made of suitable materials that resist mechanical stress over time, heat, the effects of the combustion products and any possible condensation.
- Have a vertical set-up with deviations from the axis of no more than 45° and free of bottlenecks.
- Must be suitable for the specific operating conditions of the product and have the CE marking (EN1856-1, EN1443).
- Must be adequately sized for the draught/smoke expulsion requirements that are necessary for the product to operate correctly (EN13384-1).

- The internal section is preferably circular.
 - In the case of a pre-existing product that has been used, it must be cleaned.
 - The chimney must not be shared with other appliances.
- 1) Windproof chimney pot, 2) Chimney 3) Inspection hole

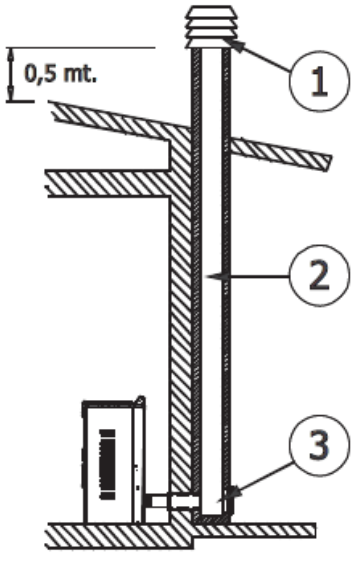
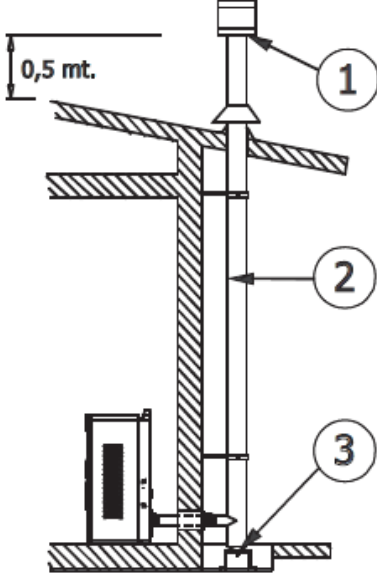
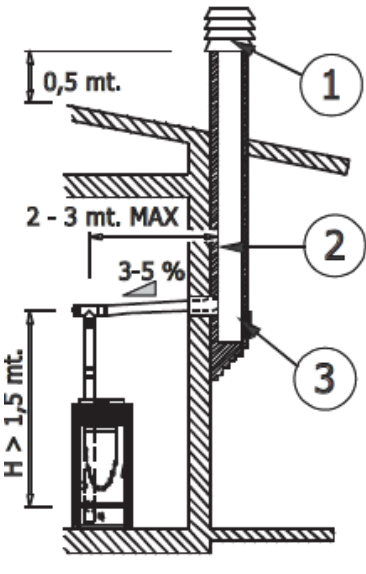
CONNECTION TO THE CHIMNEY	CONNECTION TO AN EXTERNAL DUCT WITH AN INSULATED OR DOUBLE-WALL PIPE	CONNECTION TO THE CHIMNEY
<p>The chimney's internal dimensions must not exceed 20x20 cm or 20 cm diameter; in the event of bigger sizes or bad chimney conditions (e.g. cracks, poor insulation, etc.), it is advisable to fit a stainless steel pipe of suitable diameter throughout the length of the chimney right to the top.</p>	<p>The minimum internal dimensions of the external duct must be 10x10 cm or 10 cm in diameter and must not exceed 20x20 cm or 20 cm in diameter. Only stainless steel insulated (double-wall) pipes must be used, which are smooth on the inside and fixed to the wall. Flexible stainless steel pipes must not be used.</p>	<p>The connection between the product and the chimney or the smoke duct must not have an inclination that is less than 3% in the horizontal sections, which must have a maximum overall length of 2/3 m. The vertical section between one T-fitting and another (angle) must not be less than 1.5 m.</p>
		

5.4. Chimney stack

The chimney stack is a device fitted on the top of the chimney that is designed to aid dispersion of the products of combustion in the atmosphere. Chimney stack must comply with the following requirements:

- it must have an internal section and shape the same as the flue (A);
- it must have a useful outlet section (B) of not less than twice that of the flue (A);
- the part of the chimney that emerges from the roof or remains in contact with the outside (e.g. in the case of a flat roof), must be covered with brick or tile elements and in any case well insulated;
- it must be built in such a way as to prevent the penetration of rain, snow and foreign matter into the flue and to ensure that in the event of winds from all directions and angle, discharge of the combustion products is assured (chimney stack with down-draught cowl).

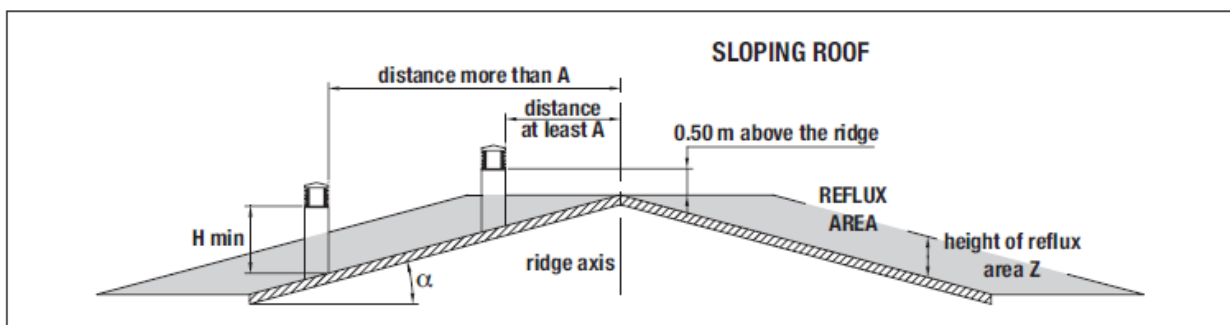
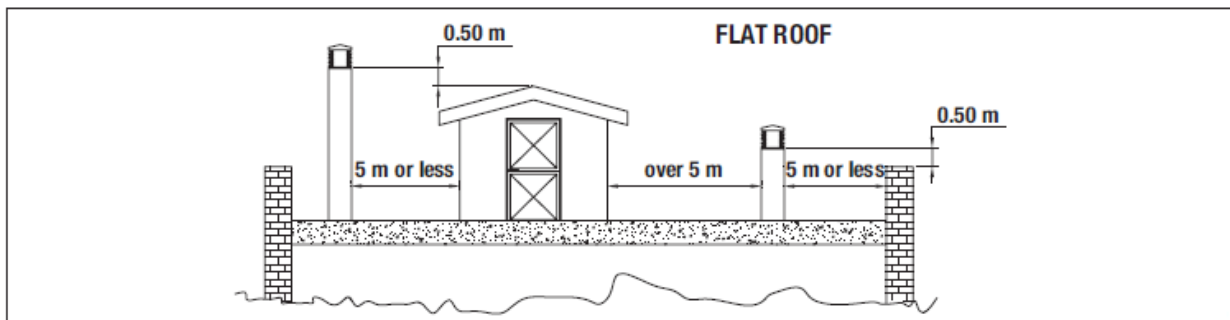
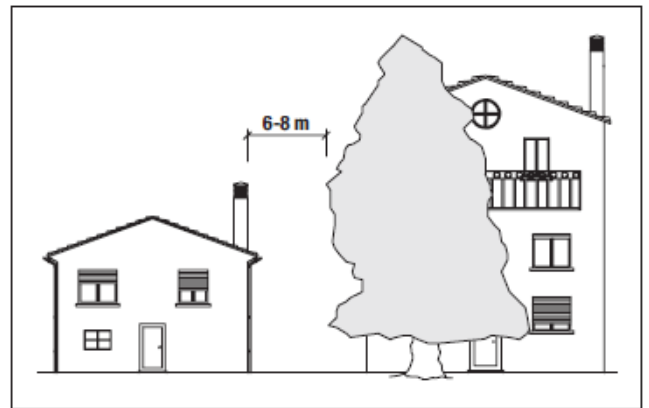
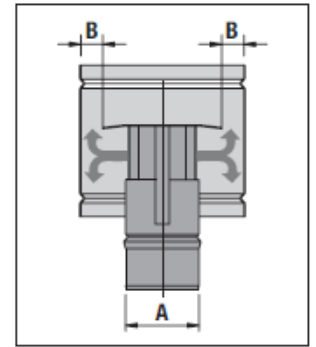
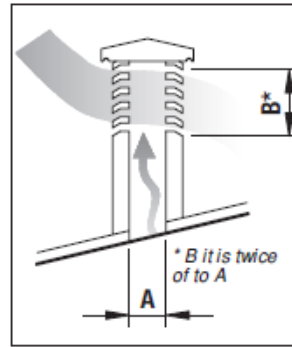

Pitch of the roof	Horizontal width of reflux area from ridge axis	Minimum height of outlet from roof	Height of reflux area
α	A	H	Z
15°	1.85 m	1.00 m	0.50 m
30°	1.50 m	1.30 m	0.80 m
45°	1.30 m	2.00 m	1.50 m
60°	1.20 m	2.60 m	2.10 m

6 INSTALLATION

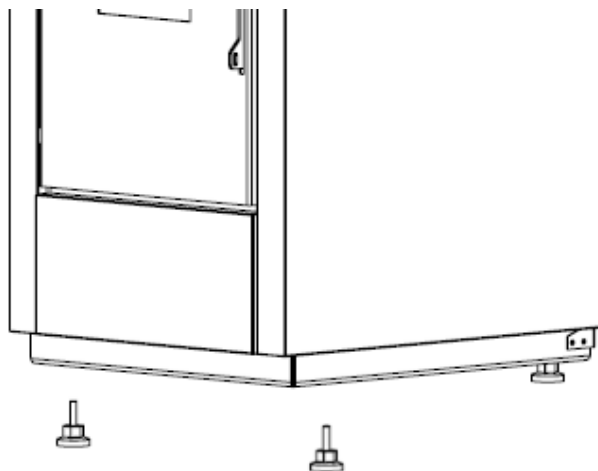

The stove is supplied complete with all its electrical components factory-tested. Open the package and cut the strips that fasten the stove to pallet. If possible, unpack stove near the place of installation. Stove body must always be kept in a vertical position when handled and moved by using carts only. Pay particular attention that its door and its glass are protected from knocks that might compromise their integrity. There are four rubber bases to be screwed onto bottom level of the stove. During installation, balance the stove, adjusting those rubber bases up and down.

The materials that make up the packaging are neither toxic nor harmful, and so require no particular disposal measures. After removing the packaging, make sure that the stove is complete and not damaged. If in doubt contact the dealer.

Electrical safety of the system is ensured only when it is properly connected to an efficient earthing system made in compliance with the safety standards in force. Check if the electrical system is suitable for the maximum power absorbed by the stove, ensuring in particular that the diameter of cables is appropriate for the power absorbed by the loads. The use of any component that is powered by electricity entails compliance with some basic rules such as:

- do not touch the appliance with wet and/or damp body parts and/or bare feet;
- do not pull the electric cables;
- do not leave the appliance exposed to weathering (rain, sun, etc.);
- do not allow the appliance used by children under 10 or inexperienced persons.

Installation of the stove accessory electrical components requires electrical connection to a 230 V - 50 Hz mains.

NOTICE

- Electrical installation must be carried out by a qualified technician only.
- Before performing connections or any operation on the electrical parts, always disconnect the power supply and make sure it cannot be accidentally reconnected.
- Please note that the stove electrical power line must be fitted with a bipolar switch with a contact gap greater than 3 mm, easy to access, in order to make any maintenance operations quick and safe.
- The power cable must be replaced by authorized technical personnel.
- If the supply cord is damaged, it must be replaced by a special cord or assembly available from the manufacturer or its service agent.

WARNING

- It is recommended to disconnect the power cable when the stove is not used.

7 INITIAL START-UP

7.1. Before start-up

Check that the fire pot is positioned correctly and rests properly on the base. Fire pot ring ensures all pellets will enter the fire pot, protects burning pellets from moving out from the pot.

Once power cable is connected in the rear part of the stove, turn the switch to position (I). To switch the stove on or off press ON/OFF button (P3) on the control panel.

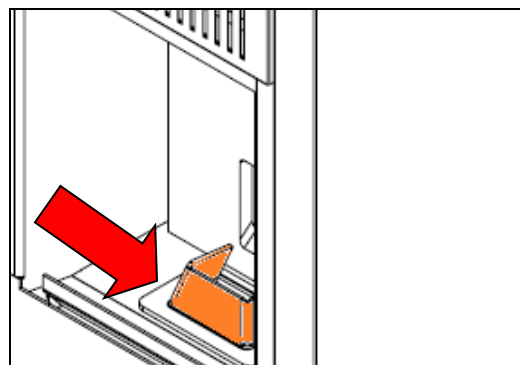

7.2. Loading the pellets

Fuel is loaded by lifting the cover on the upper part of the product. Slowly pour the pellets into the hopper. Be careful as the cover could become very hot. No fuel other than pellets, in compliance with above-mentioned specifications, is to be inserted into the hopper.

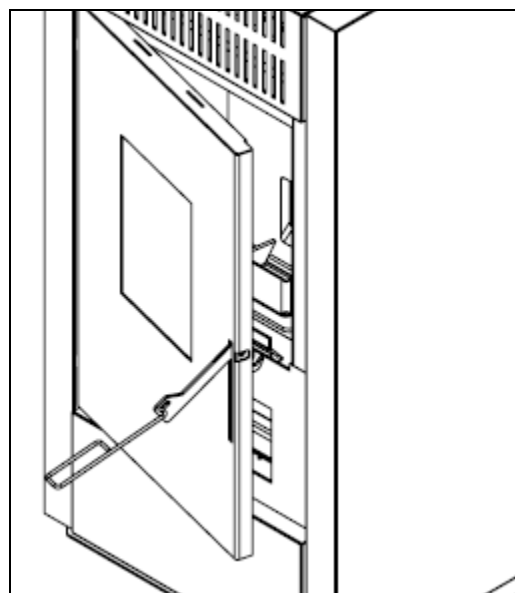

WARNING

Do not allow sawdust to accumulate on the bottom of the hopper.
Do not leave leftover pellets on top of the stove as they could catch fire!

7.3. Opening and closing the door

To open the door, use the hook hanged at the back of stove.

WARNING

- The door must be closed properly for the stove to work correctly.
- Use suitable Personal Protective Equipment (e.g. gloves) to open the stove door.

8 OPERATION

8.1. User Interface

Through the console, you can communicate with the control board simply by pressing few buttons. The display and LED indicators inform the operator of the operating status of the heater. In the programming mode, various parameters, which can be modified by pressing the keys, are displayed. Following figure describes the standard use of the console:

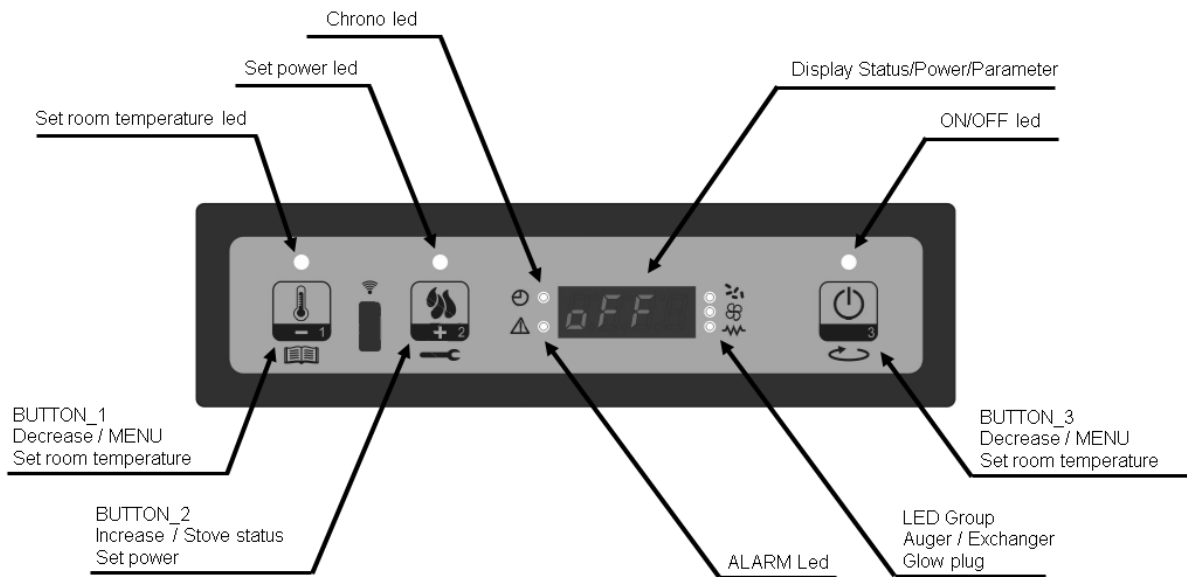

What are the Buttons for?

Button	Description	Mode	Action
1	Decrease Temperature	SET TEMPERATURE	Decrease the value of SET room temperature
		PROGRAMMING	Decrease the selected parameter
		SET POWER	Decrease the power value
2	Increase temperature	SET TEMPERATURE	Increase the value of SET room temperature
		PROGRAMMING	Increase the selected value
		SET POWER	Increase the power value
3	ON/OFF	ON	Hold for 2 seconds to switch the stove on when in off mode, or off when in on mode
		PROGRAMMING	It allows you to select the parameter to be programmed

LED	The meaning of led ON
SET ROOM	Set room programming
SET POWER	Set power programming
TIMER PROGRAM	Timer program ON
ALARM	Stove in alarm status
GLOW PLUG	Glow plug lighting
AUGER ON	Auger is moving
EXCHANGER	Exchanger ON
ON/OFF	Working state

8.2. Operating Mode

Before turning the stove on, the display appears as below.



8.2.1. Starting the Stove

To light the stove hold the P3 button for a few seconds. Once turned on, the display shows "Start" and the ON/OFF LED will flash. The stove now enters a state of pre-heating, during which the glow plug and the smoke extraction fan both turn on. Any problems during the turning on phase will be shown on the display and the stove's alarm will sound.



8.2.2. Pellet Loading

After about 1 minute, the pellet loading phase will begin, the display will show "Load Pellet" and the ON/OFF LED will flash intermittently. During the first phase, the feed screw loads the pellets into the brazier, while the speed of smoke extractor is going to change. The glow plug

and its LED remain on. After this phase, the feed screw will turn on and off periodically and the speed of the smoke extractor fan will change and the glow plug will remain on.



8.2.3. Fire ON

After the flue temperature has reached and surpassed the level set by manufacturer, the system will enter the ON mode and display will show “Flame Present”, with the ON/OFF LED flashing. In this phase, temperature should remain stable for a time period. According to settings, speed of the smoke extractor fan and feed screws period will change and the glow plug will switch off. Any problems during this phase will stop the stove and an error message will show.



8.2.4. Working Mode

After flue temperature has reached and surpassed the level and remained so for the time adjusted by manufacturer the stove will enter the WORK mode, which is its normal function. The display will show “Work” and the ON/OFF LED will be on. Power can be adjusted by pressing the P2 key and ambient temperature by pressing the P1 key. If the temperature of the air reaches the threshold, the air ventilator fan will switch on with its LED.



In this phase, after a period of time, the stove will clean out the brazier. The display will show “Cleaning brazier” the feed screw and its LED will switch on and the extractor fan will run at max speed. After the cleaning phase the stove will return to work mode.



8.2.5. Change the Set Heating Power

During the normal functioning of the stove, it is possible to change the heat emitted by pressing the P2 key (the “Set Power” LED will turn on). To increase the heat press P2 again and to decrease press P1. The level of heat selected is shown on the display. To exit this setting, wait 5 seconds without pressing any keys, or press P3.



8.2.6. Adjusting the Room Temperature Setting

To adjust the room temperature setting, simply press the P1 button. The display shows the room temperature set (SET Temperature). Pressing P1 (to reduce) and P2 (to increase) will change this number. After about 5 seconds, the number entered is memorized by stove and the display returns to normal. Alternatively, to exit you can press P3.



8.2.7. Room Temperature Reaches the Set Temperature

When the ambient temperature has reached the level set, the power of the stove automatically reduces to the minimum level. At this point, the display will show the message “Modulate”. If the room temperature drops below the set temperature, the stove will return to working mode at the power previously set.



8.2.8. Stand-by

If enabled in the menu, the stand-by function allows you to turn off the stove once the following conditions are satisfied. If for period of time set by manufacturer, the ambient temperature is higher than the set temperature by more than 3°C this function will be enabled. The display will show “Go-standby” followed by the minutes remaining.



At the end of the time period set by manufacturer, the display will show “Wait Cooling”. In this state, the feed screw (and its LED) will turn off, the air ventilator fan will turn off once it reaches the threshold and the ON/OFF LED will flash.



When the temperature of the air reaches the threshold, the stove enters stand-by mode and the display will show “Stop eco temp good”. The feed screw (and its LED), the air ventilator fan (and its LED) and the smoke extractor will all turn off.

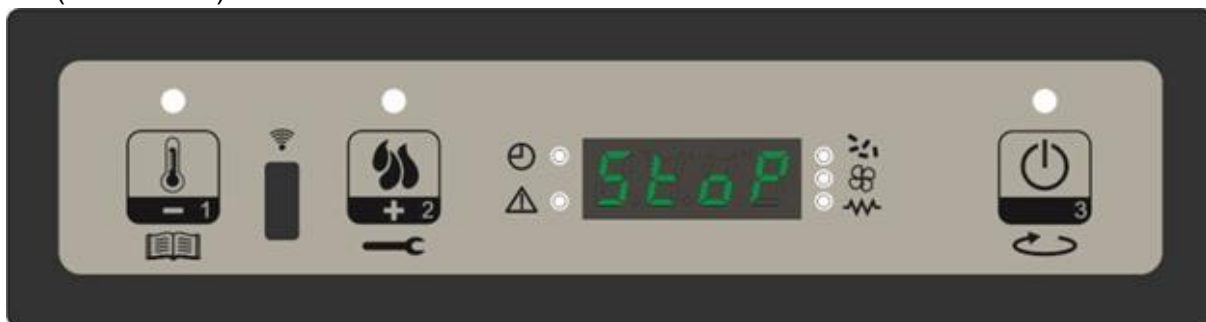

If the room temperature drops to below the set temperature by more than the threshold, the stove will turn back on.

8.2.9. Switch off the Stove

To turn off the stove, press and hold the P3 key. The display will show “Cleaning final”. The feed screw motor (and its LED) will turn off, the smoke extractor will be at the maximum speed and the ON/OFF LED will flash.



The air ventilator fan (and its LED) will remain ON, until the temperature of the air drops below the level set by manufacturer. After a period of time, if the temperature of the air is below the threshold, the stove will turn off and the display will show “Off”.



NOTICE – Improving the combustion

- A good combustion depends on several factors (type of pellet, installation, chimney conditions, draft, and air entrance to burner). If at the end of combustion periods there is too much pellet in the fire pot, or if the color of flame turns to red, or if the stove has difficulty to fire up, it means that some combustion parameters should be re-adjusted according to the real conditions in the field.
- For this purpose, please refer to “pellet type” or chimney type” adjustments in “TROUBLESHOOTING” section.
- Please note that those readjustments can only be performed by skilled technicians

8.3. MENU

To Access the menu, press and hold P1. The menu is subdivided into various levels and items that allow Access to the settings and programming of the system.

8.3.1. User Menu: The following prospectus briefly describes the structure of the menu, in particular with regards to the options available to the user.

Level 1	Level 2	Level 3	Value
M1 - set clock			
	01 - Day Week		M-T-W-T-F-

			S-S
	02 - Hours Clock		0-23
	03 - Minute Clock		0-59
	04 - Day Clock		0-31
	05 - Month Clock		1-12
	06 - Year Clock		00-99
M2- Set Chrono			
	M2-1 Chrono Enable		
		01 - Chrono Enable	on/off
	M2-2 Program Day		
		01 - Chrono Day	on/off
		02 - Start 1 day	OFF-0-23:50
		03 - Stop 1 day	OFF-0-23:50
		04 - Start 2 day	OFF-0-23:50
		05 - Stop 2 day	OFF-0-23:50
	M2-3 - Program Week		
		01 - Weekly Chrono	on/off
		02 - Start prog 1	OFF-0-23:50
		03 - Stop prog 1	OFF-0-23:50
		04 - Monday prog 1	on/off
		05 - Tuesday prog 1	on/off
		06 - Wednesday prog 1	on/off
		07 - Thursday prog 1	on/off
		08 - Friday prog 1	on/off
		09 - Saturday prog 1	on/off
		10 - Sunday prog 1	on/off
		11 - Start prog 2	OFF-0-23:50
		12 - Stop prog 2	OFF-0-23:50
		13 - Monday prog 2	on/off
		14 - Tuesday prog 2	on/off
		15 - Wednesday prog 2	on/off
		16 - Thursday prog 2	on/off
		17 - Friday prog 2	on/off
		18 - Saturday prog 2	on/off
		19 - Sunday prog 2	on/off
		20 - Start prog 3	OFF-0-23:50
		21 - Stop prog 3	OFF-0-23:50
		22 - Monday prog 3	on/off
		23 - Tuesday prog 3	on/off
		24 - Wednesday prog 3	on/off
		25 - Thursday prog 3	on/off
		26 - Friday prog 3	on/off
		27 - Saturday prog 3	on/off
		28 - Sunday prog 3	on/off
		29 - Start prog 4	OFF-0-23:50

		30 - Stop prog 4	OFF-0-23:50
		31 - Monday prog 4	on/off
		32 - Tuesday prog 4	on/off
		33 - Wednesday prog 4	on/off
		34 - Thursday prog 4	on/off
		35 - Friday prog 4	on/off
		36 - Saturday prog 4	on/off
		37 - Sunday prog 4	on/off
	M2-4 - Program Weekend		
		01 - Chrono Weekend	on/off
		02 - Star 1 Weekend	OFF-0-23:50
		03 - Stop 1 Weekend	OFF-0-23:50
		04 - Start 2 Weekend	OFF-0-23:50
		05 - Stop 2 Weekend	OFF-0-23:50
	M2-5 - Escape		set
M3 - Select Language			
	01 - Italiano		set
	02 - English		set
	03 - Francais		set
	04 - Deutsch		set
M4 - Stand-by Mode			
	01 - Stand-by		on/off
M5 - Buzzer Mode			
	01 - Buzzer Mode		on/off
M6 - Initial Load			
	01 - Initial Load		90"
M7 - Stove State			
	01 - Stove State		
		01 - Auger state	info
		02 - T minutes	info
		03 - Thermostat state	info
		04 - Flue State	info
		05 - Smoke extractor rotating status (rpm)	info
M8 - Technical Setting			
	01 - Access Key		set
M9 - Escape			
	01 - Escape		set

8.3.2. Menu M1 - SET CLOCK: Sets the current time and date. The circuit board comes equipped with a lithium battery that allows the internal clock to have an autonomy of over 3/5 years.



To Access the general programming menu, press P1 for 2 seconds. Pressing P1 (to go down) or P2 (to go up) will select the M1 item, and the display will show “M1 set time”.



Choose the desired day and press P3. Then set the hour, the minute, day, month and year by pressing P1 to go down and P2 to go up. To confirm, press P3.



8.3.3. Menu M2 - Set Timer Program

Submenu M2 -1 - Enable Chrono The menu shown on the “M2 set chrono” display allows you to enable or disable all of the functions of the chrono thermostat in on ego. To enable them, press P3 and then either P1 or P2 for On or Off respectively. Confirm by pressing P3.



Submenu M2 -2 - Program day: Select the menu “M2-2 program day” and press P3 to see and enable or disable the various parameters for programming the Daily chrono settings.



It is possible to set two functioning slots, the first with START1 Day and STOP1 Day and the second with START2 Day and STOP2 Day. These slots can be defined according to the timings set out in the table below, where the OFF setting tells the clock to ignore the command. To modify, use P1 (to go down) and P2 (to go up). Confirm with P3.

PROGRAM DAY			
Menu level	Selection	Meaning	Possible Values
M2-2-01	PROGRAM DAY	Enable chrono day	ON/OFF
M2-2-02	START 1 Day	Wake time	OFF-0-23:50
M2-2-03	STOP 1 Day	off-time	OFF-0-23:50
M2-2-04	START 2 Day	Wake time	OFF-0-23:50
M2-2-05	STOP 2 Day	off-time	OFF-0-23:50

Submenu M2 - 3- program week : The “M2-3 Program Week” menu allows you enable or disable and set weekly chrono thermostat. The weekly function has 4 independent programs. Additionally, pressing OFF on the timetable will tell the system clock to ignore the corresponding command. Following tables present the weekly program functions. To get to the next function and select it, press P3. You can exit the menu by pressing and holding P3.

ENABLE PROGRAM WEEK			
Menu Level	Selection	Meaning	Possible Values
M2-3-01	PROGRAM WEEK	Enable program week	ON/OFF

PROGRAM 1			
Menu Level	Selection	Meaning	Possible Values
M2-3-02	START PROG 1	Wake time	OFF-0-23:50
M2-3-03	STOP PROG 1	off-time	OFF-0-23:50
M2-3-04	MONDAY PROG 1	reference day	ON/OFF
M2-3-05	TUESDAY PROG 1		ON/OFF
M2-3-06	WEDNESDAY PROG 1		ON/OFF
M2-3-07	THURSDAY PROG 1		ON/OFF
M2-3-08	FRIDAY PROG 1		ON/OFF
M2-3-09	SATURDAY PROG 1		ON/OFF
M2-3-10	SUNDAY PROG 1		ON/OFF

PROGRAM 2			
Menu Level	Selection	Meaning	Possible Values
M2-3-11	START PROG 2	Wake time	OFF-0-23:50
M2-3-12	STOP PROG 2	off-time	OFF-0-23:50
M2-3-13	MONDAY PROG 2	reference day	ON/OFF
M2-3-14	TUESDAY PROG 2		ON/OFF
M2-3-15	WEDNESDAY PROG 2		ON/OFF
M2-3-16	THURDAY PROG 2		ON/OFF
M2-3-17	FRIDAY PROG 2		ON/OFF
M2-3-18	SATURDAY PROG 2		ON/OFF
M2-3-19	SUNDAY PROG 2		ON/OFF

PROGRAM 3			
Menu Level	Selection	Meaning	Possible Values
M2-3-20	START PROG 3	Wake time	OFF-0-23:50
M2-3-21	STOP PROG 3	off-time	OFF-0-23:50
M2-3-22	MONDAY PROG 3	reference day	ON/OFF
M2-3-23	TUESDAY PROG 3		ON/OFF
M2-3-24	WEDNESDAY PROG 3		ON/OFF
M2-3-25	THURDAY PROG 3		ON/OFF
M2-3-26	FRIDAY PROG 3		ON/OFF
M2-3-27	SATURDAY PROG 3		ON/OFF
M2-3-28	SUNDAY PROG 3		ON/OFF

PROGRAM 4			
Menu Level	Selection	Meaning	Possible Values
M2-3-29	START PROG 1	Wake time	OFF-0-23:50
M2-3-30	STOP PROG 1	off-time	OFF-0-23:50
M2-3-31	MONDAY PROG 1	reference day	ON/OFF
M2-3-32	TUESDAY PROG 1		ON/OFF
M2-3-33	WEDNESDAY PROG 1		ON/OFF
M2-3-34	THURDAY PROG 1		ON/OFF
M2-3-35	FRIDAY PROG 1		ON/OFF
M2-3-36	SATURDAY PROG 1		ON/OFF
M2-3-37	SUNDAY PROG 1		ON/OFF

Submenu M2 - 4 - Program Weekend : Allows you to enable/disable and set chrono thermostat function on the weekend (days 6 and 7, or Saturday and Sunday).

PROGRAM WEEKEND			
Menu Level	Selection	Meaning	Possible Values
M2-4-01	PROGRAM WEEKEND	Enable Chrono Weekend	ON/OFF
M2-4-02	START 1 Weekend	Wake time	OFF-0-23:50
M2-4-03	STOP 1 Weekend	Off-time	OFF-0-23:50
M2-4-04	START 2 Weekend	Wake time	OFF-0-23:50
M2-4-05	STOP 2 Weekend	Off-time	OFF-0-23:50

To enable, press P3 on the “chrono weekend” item and select “on” by pressing P1 (to go down) or P2 (to go up). Selecting the times under Start 1 weekend and Stop 1 weekend will set the times that the stove will function on Saturday, while Start 2 weekend and Stop 2 weekend will set the operating times for Sunday.

8.3.4. Menu M3 - Language selection

Allows you to set the language from those available. To move to the next language, press P2 (to go up) and to go back press P1. To confirm, press P3.



8.3.5. Menu M4 - Stand-by

Allows you to enable or disable Standby mode. Once you have selected the M4 menu using the P3 key, press P1 (to go down) or P2 (to go up) to switch between ON and OFF and vice versa.



8.3.6. Menu M5 - Alarm mode

Allows you to enable or disable the buzzer on the controller when the alarm goes off. To enable or disable, press P1 or P2 respectively. To confirm, press P3.



8.3.7. Menu M6 - First charge

This function is only available when the stove is OFF. It allows the feed screw to load at the first start of the stove, when the pellet tank is empty. After selecting the M6 menu, the display will show "Press again". Press P2 (to increase). The ventilator will turn on at maximum speed, the feed screw (and its LED) will turn on and remain on until the end of the shown on the display, or until you press the P3 key.



8.3.8. Menu M7 - Stove status

In menu M7, the display will show the status of several variables during the operation of the stove in work mode. The table below shows an example of the meaning of these numbers.

Visualized Status	Meaning
3,1"	Feed screw pellet loading status
52'	Time out
Toff	Thermostat status
106°	Flue temperature
1490	Smoke extraction speed

8.3.9. Menu M8 - Technical Settings

This item in the menu is accessible only to the technician who installed the stove. Once the Access key is entered, it allows you to set the various parameters of the stove's operation by pressing P1 (to go down) and P2 (to go up).

8.3.10. Menu M9 - Escape

Selecting this item by pressing P3, you can exit the menu and return to the previous position.

8.4. ALARMS

If a problem is detected during operation, the stove will intervene and alert you by turning on the alarm LED and making noise. The following alarms could sound:

Origin of the alarm	Display
Black-out	AL 1 ALAR AL 1 BLAC-OUT
Flue gas temperature probe	AL 2 ALAR AL 2 PROBE EXHAUST
Flue gas over-temperature	AL 3 ALAR AL 3 HOT EXHAUST
Flue encoder damaged	AL 4 ALAR AL 4 FAN FAILURE
Ignition failure	AL 5 ALAR AL 5 NO LIGHTIN-
Pellet absence	AL 6 ALAR AL 6 NO PELLETT
Thermal safety over-temperature	AL 7 ALAR AL 7 SAFETY THERMAL
Depression absence	AL 8 ALAR AL 8 FAILURE DEPRESS-

Every alarm causes the stove to immediately shut down!

State of alarm occurs after reaching a time defined by manufacturer, except for the blackout alarm, all alarms re activated after a period of time. And can be reset by pressing and holding P3 key. For security reasons, each time you reset an alarm, the stove will automatically be turned off. When the alarm is activated, the alarm LED will turn on and where enable, the buzzer will buzz intermittently. If the alarm is not reset, the stove will turn itself off and the display will continue to show an alarm message.

8.4.1. Black-out

During the stove's work mode, it might run out of energy. When it restarts, if the black-out period was less than defined by manufacturer, the stove will re-enter the work mode, otherwise, the alarm will sound. The display will show message "AL1 alar al 1 Blackout" and the stove will turn itself off.



8.4.2. Flue gas temperature probe alarm

The alarm will sound if the exhaust probe is faulty. The alarm LED will turn on, the display will show “Al2 alar al 2 Probe exhaust” and the stove will turn itself off.

8.4.3. Flue gas over-temperature alarm

The alarm will sound if the exhaust probe reaches a temperature higher than the fixed, unalterable value given in the parameters. The display will show “Al3 alar al 3 Hot exhaust” and the stove will turn itself off.

8.4.4. Flue encoder alarm

The alarm will sound if the smoke extraction fan is faulty. The display will show “Al 4 alar al 4 Fan failure-damaged”.

8.4.5. Ignition failure alarm

The alarm will sound when the stove fails to turn on properly, i.e. if the within the period of time setted by manufacturer, the air temperature does not rise above a threshold. The alarm will come on and the display will show “Al5 alar al 5 No lightin-“

8.4.6. Pellet absence alarm

In work mode, if the flue temperature drops to below a pre-set value, the alarm will sound. The display will show “Al6 alar al 6 no pellet”.

8.4.7. Over temperature thermal safety alarm

The alarm will sound when the general security thermostat reaches a temperature higher than the trigger threshold. The thermostat will intervene and turn off the feed screw and the controls will indicate a state of alarm, with the alarm LED on and the display showing “ Al 7 alar al 7 safety thermal”. The stove will turn itself off.

8.4.8. Depression failure alarm

The alarm will sound when the air pressure switch reaches a pressure reading lower than the trigger threshold. The pressure switch will turn off the feed screw and the controls will indicate a state of alarm (with the alarm LED on), while the display will read “Al 8 alar al 8 failure depress-“. The stove will then turn itself off.

WARNING

- During periods of disuse, the stove must be unplugged. For greater safety, especially if there are children around, we recommend removing the supply cable from the rear of the stove.

NOTICE

- The stove will be subject to expansion and contraction during the start-up and cooling phases, therefore light creaking noises may be heard. This is absolutely normal as the structure is made of laminated steel and must not be considered a defect.
- It is extremely important to make sure the product is not immediately overheated and the temperature is increased gradually, initially using low power. This will prevent damaging the welds and the steel structure.
- Avoid touching the stove during the initial start-up, as the paint in this stage hardens; by touching the paint, the steel surface may be exposed.
- After a long period of inactivity, remove any pellets left in the hopper (using a vacuum cleaner with a long pipe), as they could have absorbed moisture, thereby altering their original characteristics and no longer being suitable for combustion.

9 SAFETY DEVICES

The product is supplied with the following safety devices

AIR PRESSURE SWITCH

Monitors pressure in the smoke duct. It is designed to shut down the pellets feed screw in the event of an obstructed flue or significant back-pressure (wind).

SMOKE TEMPERATURE PROBE

Detects the temperature of smoke, there by enabling start-up or stopping the product when the temperature drops below the preset value.

ELECTRICAL SAFETY

The product is protected against sudden current surges by a main fuse in the power supply panel on the rear part of the product. Other fuses that protect the electronic boards are found on the latter.

BACK FLAME / FIRE SAFETY

A manual reset type safety thermostat protects the stove from any flame back flow to fuel hopper.

SMOKE FAN

If the fan stops, the electronic board promptly shuts off the pellets supply and an alarm message is displayed.

GEAR MOTOR

If the gear motor stops, the stove will continue to run until the flame goes out due to lack of fuel and until a minimum level of cooling is reached.

TEMPORARY POWER CUT

If the power cut lasts less than 10" the stove returns to its previous operating status; if it lasts more it carries out a cooling/restart cycle.

FAILED START-UP

If during ignition no flame develops, the stove will go into alarm condition.

10 CLEANING AND MAINTENANCE

Refer to following table for periodical maintenance and cleaning

Part of the stove	Every two days	Every 60-90 days	End of season by service technician
Fire pot	o		
Fire pot housing	o		
Ash tray	o		
Front glass	o		
Heat exchanger		o	
Lower compartment (smoke chamber)		o	
Flue pipe / connection			o
Electro-mechanical components			o
Thermostat / sensor			o
Fibre rope on front door			o

10.1. Cleaning to be performed every 2 days by the user

Fire Pot

Remove the burning pot from its compartment and free the holes using the brush supplied with the stove or an appropriate tool. If the pellets in the hopper finish, unburnt pellets may accumulate in the burning pot, you can also use vacuum cleaner for unburnt pellets removal. Always empty the residue in the burning pot before starting-up.

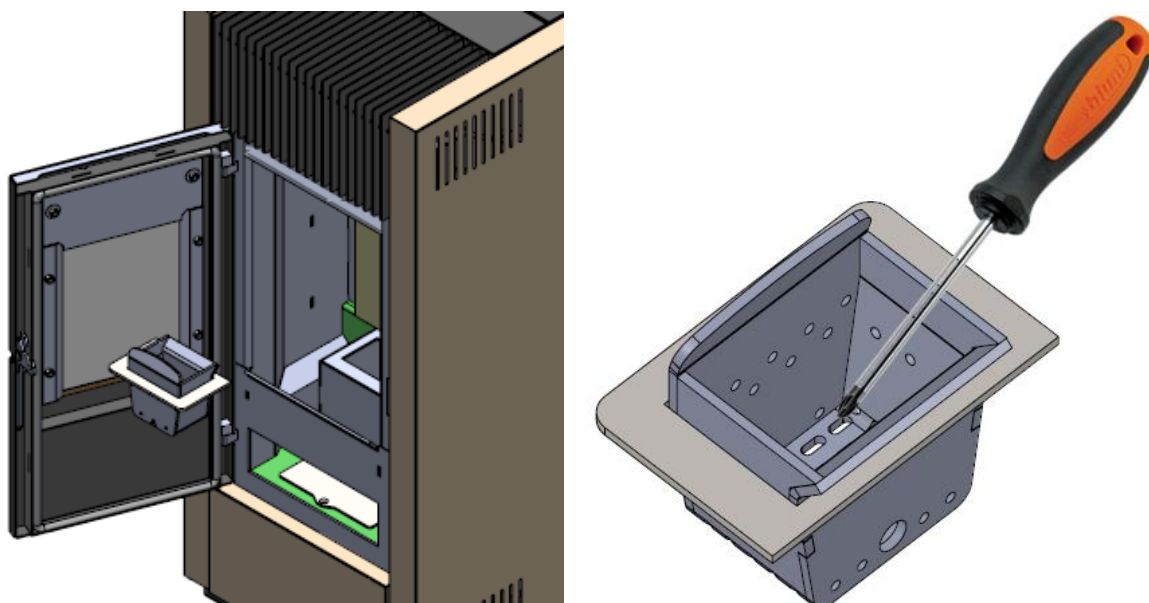

Fire pot housing

Clean the fire pot housing, preferably using a vacuum cleaner.

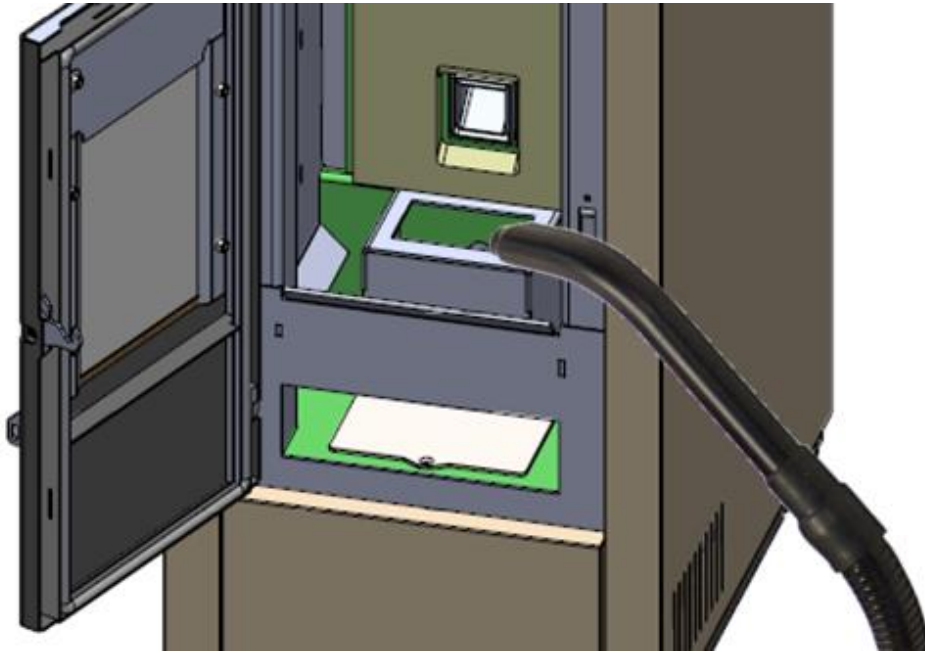

Ash Pan and Combustion Chamber

Take the ash tray out with the help of the tool supplied with the stove (do not touch the ash tray by hand when it is hot), and deposit the ash and the residue. Some of ash will accumulate on the combustion compartment. After removing the fire pot, just sweep this ash into ash pan. **Only if the ash is completely cold**, a vacuum cleaner can be used to remove it. Use a drum-type vacuum cleaner that is suitable for picking up particles of a certain size. Experience and the quality of the pellets will determine the cleaning frequency required. **However, it is recommended not to exceed 2 or 3 days.**

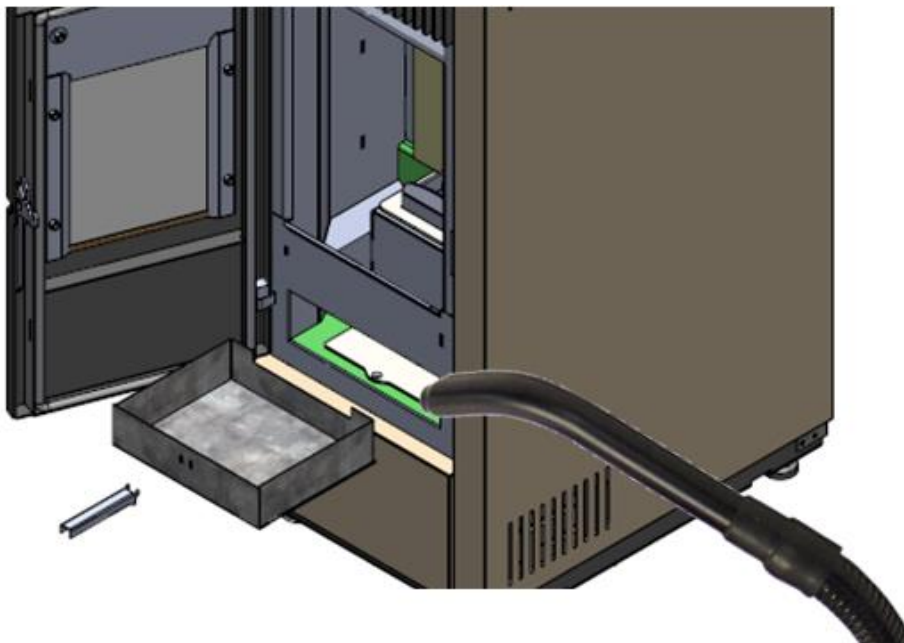

NOTICE

- REMEMBER THAT ONLY A CORRECTLY POSITIONED AND CLEAN BRAZIER CAN GUARANTEE START-UP AND OPTIMAL OPERATION OF YOUR PELLET STOVE.

NOTICE – Disposal of ashes

- The ashes should be placed in a metal container with a sealed cover. The sealed container should be placed on a noncombustible surface at a safe distance from combustible materials until the cinders have been completely extinguished.
- Only when they have been fully extinguished can the ashes be thrown away with organic waste, assuming that nails or other nonorganic material are not present.
- Make sure that the ash is completely cold before emptying it into a suitable container.

Cleaning the Glass

Clean the glass with a damp cloth or damp paper rubbed in ashes. Rub the glass until it comes clean. Although it is likely that tar will build up on the glass during the lighting stage, it will burn off with the stove in full operation. If, however, the tar is left to build up over a long period it will require more effort to remove. We therefore recommend that the glass be cleaned daily before lighting the stove.

NOTICE

- Do not clean the glass while the stove is working and the glass is HOT; do not use abrasive sponge and corrosive substance such as solvents.

10.2. Monthly cleaning (every 60-90 days)

Heat exchanger

For Astra 6 / 8

- Remove the fire pot
- Using an appropriate tool, loosen the screw fastening the combustion chamber protection board
- Grasp the combustion chamber protection refractory board and take it out of the stove
- Move the combustion chamber rear sheet plate a bit up and take it out from the stove.
- Remove the ash tray
- Loose the screw fixing smokehood cleaning cover and take this part out of the stove.

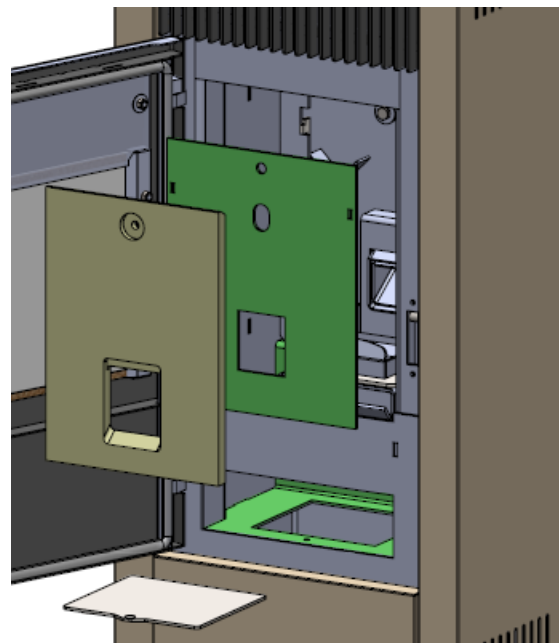
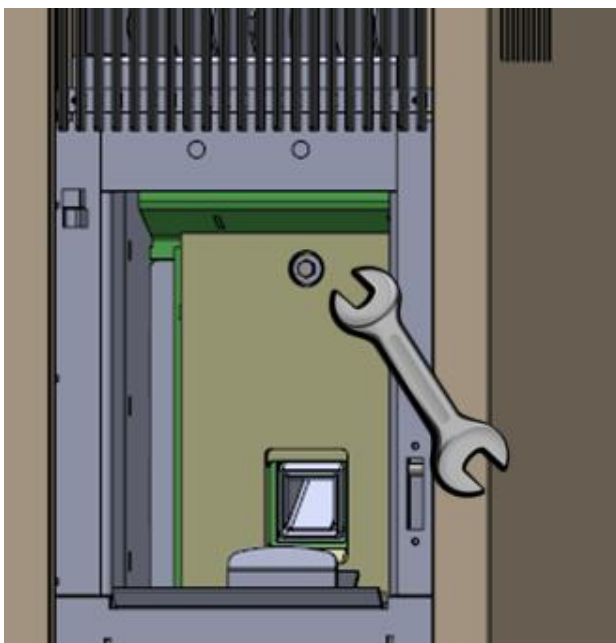

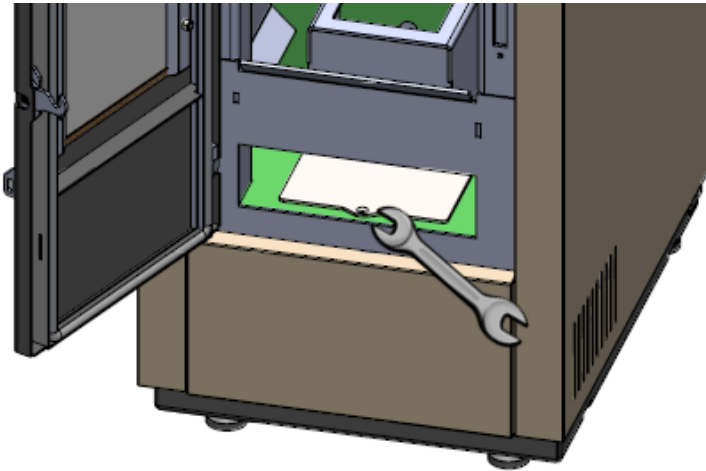

For Astra 12

- Remove the fire pot
- Remove the combustion chamber upper board (1), raising one edge up, and the other edge down.
- Move refractory board fixing sheet (2) up, and take it out from combustion chamber.
- Grasp the combustion chamber protection refractory board (3), and take it out of the stove
- Move the combustion chamber rear sheet plate a bit up and take it out from the stove.
- Remove the ash tray
- Loosen the screw fixing smokehood cleaning cover and take this part out of the stove.

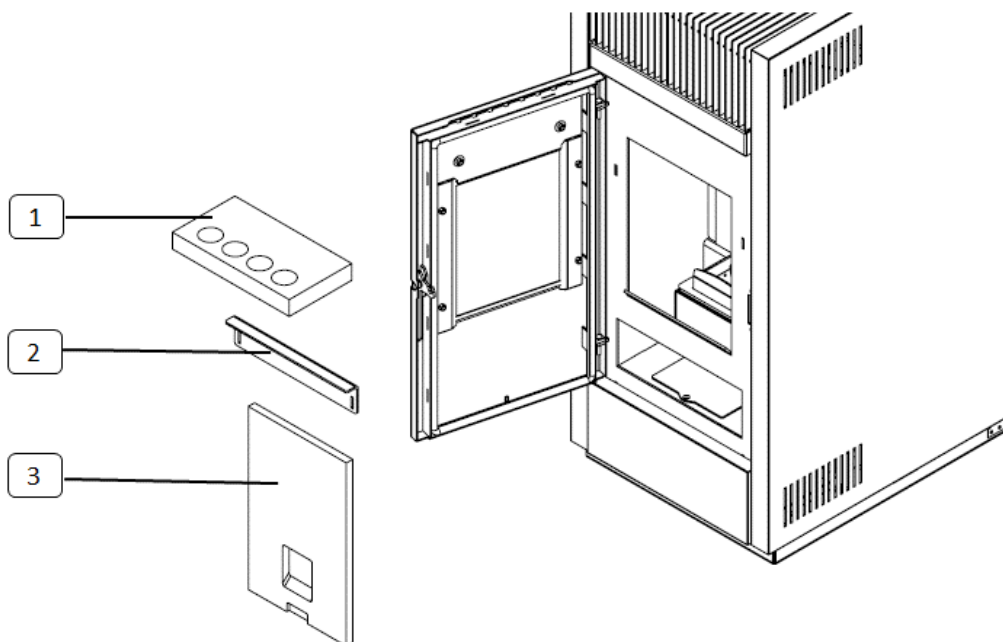

- Now clean all surfaces around the combustion chamber with supplied original brush with plastic handle. Move all deposits down into the ash compartment under combustion chamber.
- Remove the deposited ash and combustion products including propeller of the smoke extractor (as much as you can reach) with a help of vacuum cleaner (or available brush / cloth)

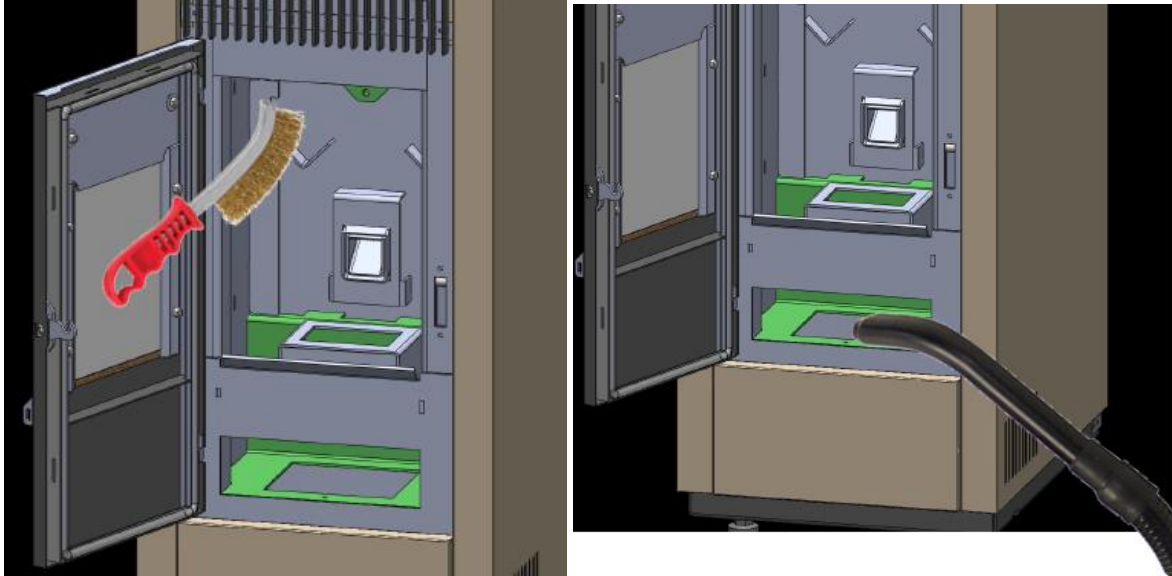

10.3. Periodic maintenance (end of each heating season)

The scheduled maintenance work listed below must be carried out **ONCE A YEAR** and prior to starting up the appliance or after a long period of inactivity. This work is necessary to ensure that the appliance remains efficient and safe.

- Thorough cleaning of the smoke chamber.
- Check and clean the smoke outlet and flue system.
- Clean away dust and cobwebs from the area inside the cladding.
- Clean moving parts and mechanisms (motors / ventilation fan).
- Check the electrical parts / sensors / thermostats / switches
- Check the tightness and state of the gaskets/seals of the glass door.
- Check the seal and tightness of the joints on flue
- Carry out all maintenance and checks required for correct operation and adaptation to safety regulations.
- Light the stove in accordance with instructions given in the paragraph.

NOTICE

- All cleaning and maintenance must be carried out with the power cable disconnected from the power supply.

10.4. Cleaning the Flue System

Until you have got reasonably used to the operating conditions of the stove, we recommend that this maintenance be carried out on a monthly basis. Remove the plug from the Tee and clean the pipes. If necessary, particularly on the first few occasions, we recommend calling in a qualified technician.

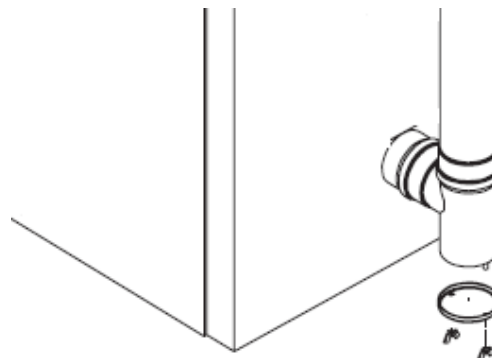

Cleaning the smoke duct and general checks

Clean the smoke exhaust, especially around the T-fittings, curves and any horizontal sections. For information on cleaning the flue, contact a chimney sweeper. Check the tightness of the ceramic fibre gaskets on the stove door. If necessary, order new replacement gaskets from the retailer or contact an authorized service centre to carry out this task.

NOTICE

- The frequency with which the smoke exhaust must be cleaned depends on the use of the stove and the type of installation.
- We recommend contacting an authorized service center for end-of-season maintenance and cleaning as the above-mentioned operations will be performed together with a general inspection of the components.

End-of-season shutdown

At the end of season, before shutting down the stove, we recommend completely removing pellets from the hopper with the use of a vacuum cleaner with an extension.

11 ALARMS AND TROUBLESHOOTING

If a problem is detected during operation, the stove will intervene and alert you by turning on the alarm LED and making a noise. The following alarms could sound:

Origin of Alarm	Display
Black-out	AL 1 OUT
Flue gas temperature probe	AL 2 FUME PROBE
Flue gas over-temperature	AL 3 HOT FUME
Flue encoder damaged	AL 4 FAN FAILURE
Ignition failure	AL 5 FAILED IGNITION
Pellet absence	AL 6 NO PELLET
Thermal safety over temperature	AL 7 THERMAL SAFETY
Depression absence	AL 8 FAILURE DEPRESS-

Every alarm causes the stove to immediately shut down! State of alarm occurs after reaching a pre-set time, **EXCEPT FOR THE BLACKOUT ALARM**, and can be reset by pressing and holding the P4 key. For security reasons, each time you reset an alarm, the heater will automatically be turned off. When the alarm is activated, the segment alarm LED will turn on and, where enabled, the buzzer will buzz intermittently. If the alarm is not reset, the heater will turn itself off and the display will continue to show an alarm message.

Black-out

During the heater's work mode, it might run out of energy. When it restarts, if the blackout period was less than 30 seconds, the heater will re-enter the WORK mode; otherwise, the alarm will sound. The stove will turn itself off.

Smoke Temperature Alarm

The alarm will sound if the exhaust probe is faulty. The stove will turn itself off.

Smoke Over-Temperature Alarm

The alarm will go on if the exhaust probe reaches a temperature higher than the fixed, unalterable value given in the parameters. The stove will turn itself off.

Smoke Encoder Alarm

The alarm will sound if the air ventilator is faulty.

Ignition Failure Alarm

The alarm will go on when the heater fails to turn on properly, i.e. if, within the period of time given for ignition, the smoke temperature does not rise above the pre-set parameter. The alarm will show on display and stove turns off itself.

Pellet Absence Alarm

In work mode, if the fumes temperature drops below 40°C, the alarm will sound. The alarm will show on display and stove turns off itself.

Stove is not Firing-up Automatically (Needs daily cleaning too often)

If the stove can't fire up more than a few times without cleaning and needs cleaning in a few hours of working, it means there could be a problem about fuel or air input or chimney. Please be sure that the air input of the stove is not blocked by any material. To check origin of problem and solve it, please refer to the following steps:

- 1- Perform a cleaning explained on section 10.1 (every 2 days)
- 2- Fire up the stove and watch until the stove burns up. Check for pellet level on a few stages.
 - After preloading of pellets and starting to load pellet/wait fire, how high is the pellet level in the burning pot? It must be close to igniter hole. If it's more than that level it means there is too much pellet loading while burning up. This can happen because of the length or diameter of the pellets. It's necessary to make pellet type optimization.
 - If there is no problem on preloading section, please keep watching the pellet level until stove goes to maximum power. After you see the fire, if fuel level increases or fuel level goes up to secondary air holes level of burning pot on any stage (before or after fire presents), it means that less air is going into burning pot than stove needs (could be low draft on chimney or blockage on air input of the stove). Please check the air input of the stove, perform a cleaning explained on section 10.2 (Monthly Cleaning) and check the chimney installation explained on section 5. If the chimney is properly installed be sure it's clean too. After that, please retry to start the stove and check for the same process again. If there is still a problem, it's necessary to make chimney type optimization.

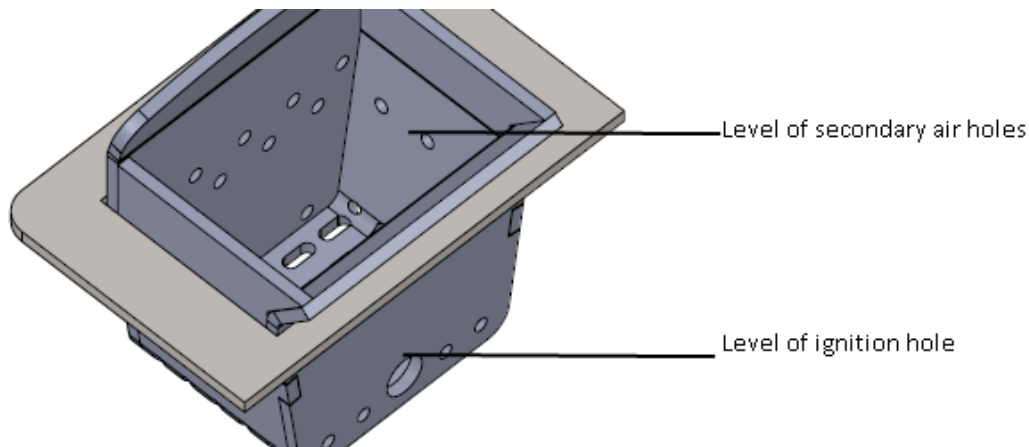

Pellet Type Optimization and Chimney Type Optimization

WARNING

The following section is reserved for professional technicians with specific knowledge concerning the product. Random changes in the settings could cause severe damage to the stove, people and the environment. For this, producer assumes no responsibility.

To get to the Technical Menu, enter the main menu by pressing the P1 key for 2 seconds. Move up and down using P1 and P2 until you see M8 "Technical Settings" and press P3 to enter.

Next, press P1 or P2 (press and hold to scroll fast) to enter the access key A9.

Press P3 to confirm the access key and to access the submenu, where you can configure the various parameters of the stove. The table below shows the submenu.

Menu	Display
M8-1	Settings Factory
M8-2	Set general
M8-3	Type pellet
M8-4	Type chimney
M8-5	Data bank
M8-6	Test outputs
M8-7	Reset part time
M8-8	Reset alarm
M8-9	Counter memories
M8-A	Escape

Within the submenus, by pressing P3 repeatedly you can scroll through all the configuration parameters. To modify a parameter, press P1 (to decrease) or P2 (to increase). Confirm by pressing P3. The system will memorize the value entered and the display will show the next parameter. After last parameter, you can exit the menu by pressing P3 again.

Pellet Type Optimization:

This optimization has 2 steps:

First, the preload time must be optimized. From M8-2, General Setting menu, you can adjust the preload time with Pr40 parameter. Pellet level on burning pot after preload must be close to burning pots ignition hole upper level. Since the problem is over loading, pellet loading time must be decreased. Please note the original value and the adjusted value.

Second, work phase must be adjusted with noted values. To adjust that, please use following formula and following changes.

$$\text{Percentage} = ((\text{Adjusted value} / \text{Original value}) - 1) \times 100$$

Adjust the Pellet Type from M8-3 Pellet Type menu. Pressing P1 or P2 will modify the pellet loading percentage up to a maximum value of +9 and down to a minimum value of -9. Each step increases or decreases it by 3% of the total period of the feed screw with respect to the default period (Pellet Type=0).

For example:

Noted parameters are:

Original value = 50

Adjusted value = 41

Calculations:

$$\text{Percentage} = ((41 / 50) - 1) \times 100 = (0,82 - 1) \times 100 = - 18 \%$$

$$\text{Pellet Type} = -18 / 3 = -6$$

Set Pellet Type to -6

Chimney Type Optimization:

This optimization has 2 steps:

First, ignition fan speed must be optimized. Since the problem is pellet level is increasing on the burning pot, fan speed must be increased before work phase. From M8-1 Settings Factory menu you can increase Pr16 and Pr17 parameters to adjust fan speed on needed functioning stages. Please note the original and the adjusted parameters.

Second, use the same logic of the percentage formula to adjust the M8-4 Chimney Type parameter.

Adding Cleaning Phases on Work Phase

After optimizations are made, adding initial cleaning phases will help stove to work for a longer time without daily cleaning needed. To activate the initial cleaning set the following parameters from M8-1 Settings Factory menu.

Pr03 = 10

Pr08 = 2700

Pr09 = (Changing according to stove output, set it same as Pr06)

Pr12 = 30

12 STOVE CONTROL PANEL ELECTRICAL SCHEME

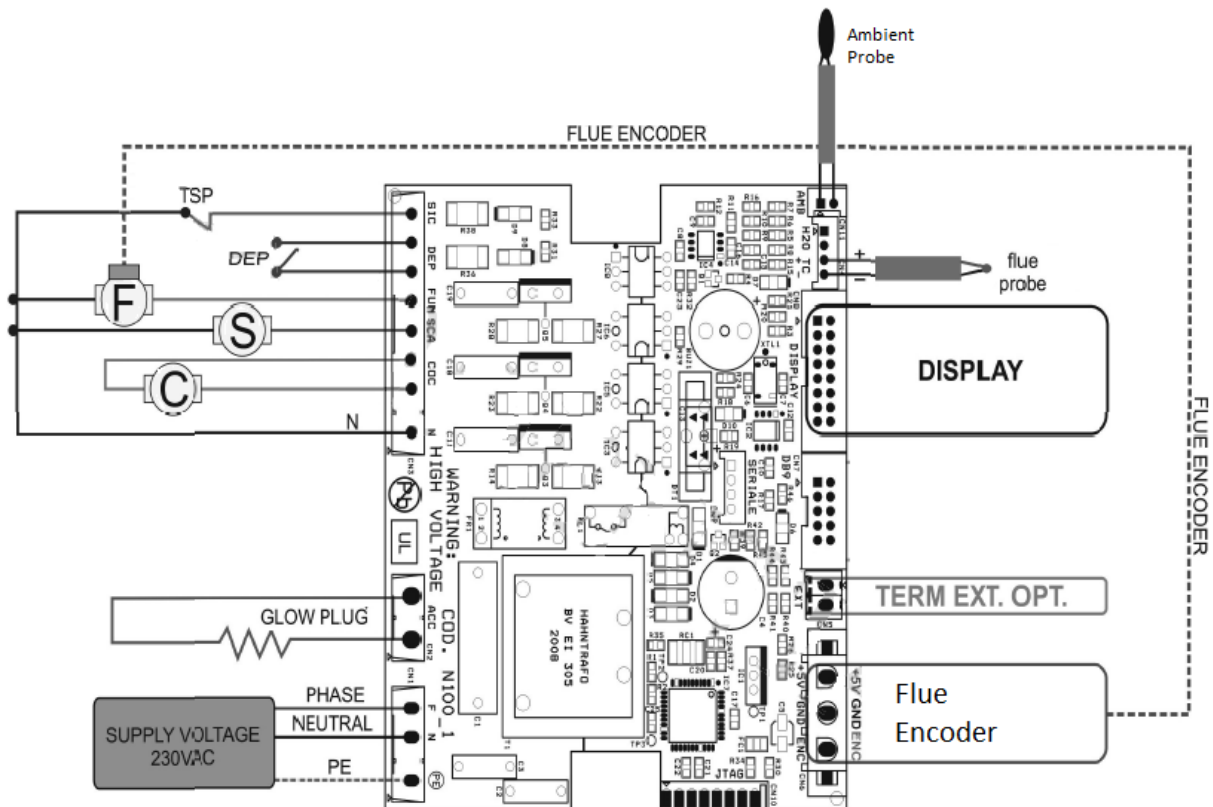

- TSP = Safety Thermostat
 DEP = Air Pressure Switch
 F = Flue Fan
 S = Air Exchanger Fan
 C = Auger

WARNING

- Before doing any work on the stove related with electricity, ensure that the power supply cable is disconnected from the network electricity.
- Sensor wires, sensors and keyboard wires must be mounted so that they cannot be accessed without disassembling the combustion device.
- Earth connection must be connected to the controller and to the metal part of the combustion device.
- Some of the wires carry dangerous voltages. Disconnect the controller from the mains power supply prior to any service or mounting operation.
- Do not exchange high voltage and low voltage connectors during mounting of the controller.

START-UP / COMMISSIONING FORM

1/2

END-USER INFORMATION

NAME / SURNAME	:	_____
ADDRESS	:	_____
CITY / PROVINCE	:	_____
COUNTRY	:	_____
E-MAIL / GSM	:	_____
SIGNATURE	:	_____

PRODUCT INFORMATION

PRODUCT MODEL	:	_____
EXTRAS 1	:	_____
EXTRAS 2	:	_____
INVOICE DATE and NUMBER	:	_____
SERIAL NUMBER	:	_____

COMMISSIONING OF THE DEVICE

DATE OF COMMISSIONING	:	_____
AUTHORIZED COMPANY for COMMISSIONING	:	_____
ADDRESS	:	_____
E-MAIL / GSM	:	_____
SERVISER NAME / SURNAME	:	_____
SERVISER STAMP and SIGNATURE	:	_____

- Warranty period is 2 (two) years, and starts with signing of this document
- One copy of this document shall be handed to end-user
- General checks on next page should be completed for future reference

START-UP / COMMISSIONING FORM

2/2

General Checks	Check	Comments
Wall plug voltage measurement	_____ V (AC)	
There is no damage because of transportation		
Chimney is clean, functioning well and meets the requirements defined in manuals		
Outputs are tested before start-up and working correctly		
Plumbing plant installation is made according to manuals, and necessary sensors are installed		
Optimization for auger / chimney calibration (if needed) is made		
Purchased optional elements are installed correctly, and tested		

End-User Notification	Check	Comments
User is informed about boiler/stove cleaning and service cycles		
User is informed about errors and how to act when they are shown		
User is informed about combustion power selection and setting necessary thermostats		
User is informed about boiler/stove functioning, operating, fuel quality and warranty conditions		

REMARKS / DIFFERENCES